

This document reproduces the complete and unabridged text of a United States Army Field Manual first published by the Department of the Army, Washington DC.

All source material contained in the reproduced document has been approved for public release and unlimited distribution by an agency of the US Government. Any US Government markings in this reproduction that indicate limited distribution or classified material have been superseded by downgrading instructions that were promulgated by an agency of the US government after the original publication of the document.

No US government agency is associated with the publishing of this reproduction.

Digital viewer interface reformatting, viewer interface bookmarks and viewer interface links were revised, edited, ammended, and or provided for this edition by I.L. Holdridge.

This page and the viewer interface reformatting
© I.L. Holdridge 1999.
All rights reserved.

FIELD MANUAL

No 701-58

HEADQUARTERS
DEPARTMENT OF THE ARMY
WASHINGTON, DC, 27 May 1987

PLANNING LOGISTICS SUPPORT FOR MILITARY OPERATIONS

TABLE OF CONTENTS

		<i>Paragraph</i>	<i>Page</i>
CHAPTER	1. PURPOSE AND SCOPE		
Section	I. Introduction	1-1-1-3	1-1
	II. Military Planning	1-4-1-6	1-2
CHAPTER	2. ORGANIZATION FOR LOGISTICS SUPPORT		
Section	I. General	2-1, 2-2	2-1
	II. Planning Responsibilities	2-3-2-8	2-2
	III. Logistics Support Responsibilities	2-9-2-10	2-6
CHAPTER	3. DEPARTMENT OF DEFENSE GUIDANCE		
Section	I. Introduction	3-1, 3-2	3-1
	II. Joint Logistics Policy and Guidance	3-3-3-5	3-2
	III. Management of War Reserve Stocks	3-6-3-8	3-4
CHAPTER	4. MILITARY PLANNING SYSTEMS		
Section	I. General	4-1-4-11	4-1
	II. National Military Planning	4-12	4-7
	III. Guidance Documents and the Joint Reporting Structure	4-13-4-16	4-10
	IV. The Army Planning System	4-17, 4-18	4-15
	V. Continuity of Operations Planning	4-19-4-21	4-18
CHAPTER	5. JOINT OPERATIONS PLANNING		
Section	I. Introduction	5-1-5-3	5-1
	II. Data Automation Systems to Support Joint Operations Planning	5-4-5-7	5-3
	III. The Joint Planning Process	5-8-5-17	5-7
CHAPTER	6. LOGISTICS PLANNING RESPONSIBILITIES OF SUPPORTED AND SUPPORTING COMMANDERS		
Section	I. General	6-1	6-1
	II. Logistics Responsibilities of Unified Command	6-2-6-9	6-1
	III. Logistics Planning by Supported and Supporting Commands and Agencies	6-10-6-18	6-8
CHAPTER	7. US ARMY MATERIEL COMMAND (AMC) ROLE IN LOGISTICS PLANNING		
Section	I. General	7-1	6-1
	II. AMC LOGPLAN Development	7-2-7-5	7-4
	III. AMC Relationship With Supported Forces	7-6-7-8	7-19
CHAPTER	8. COMBAT SERVICE SUPPORT PLANNING		
Section	I. Combat Service Support Force Planning	8-1-8-4	8-1
	II. Supply Planning	8-5-8-15	8-4
	III. Maintenance Planning	8-16-8-20	8-12
	IV. Transportation Planning	8-21-8-26	8-16
	V. Field Services Planning	8-27	8-21
	VI. Facilities Planning	8-28-8-30	8-21
	VII. Personnel Service Support	8-31	8-23
	VIII. Summary	8-32	8-24
CHAPTER	9. HEALTH SERVICE SUPPORT PLANNING		
Section	I. Introduction	9-1-9-2	9-1
	II. Unified Command Medical Planning	9-3-9-4	9-2

This manual supersedes FM 701-58, 1 September 1982.

FM 701-58

	<i>Paragraph</i>	<i>Page</i>
		<i>Page</i>
	III. Services Within the Health Service Support System.....	9-5—9-13 9-6
CHAPTER	10. PLANNING EMERGENCY SUPPORT FOR ALLIES.....	10-1—10-5 10-1
CHAPTER	11. FORCE MOBILIZATION PLANNING RESPONSIBILITIES.....	11-1—11-8 11-1
CHAPTER	12. INDUSTRIAL PREPAREDNESS PROGRAM.....	12-1—12-15 12-1
CHAPTER	13. MILITARY ASSISTANCE TO CIVIL AUTHORITIES	
Section	I. General.....	13-1—13-7 13-1
	II. Civil Defense.....	13-8—13-12 13-6
	III. Civil Disturbances.....	13-13—13-19 13-8
	IV. Disaster Relief.....	13-20—13-23 13-11
	V. Military Support of Other Emergencies.....	13-24 13-12
		<i>Page</i>
APPENDIX	A. SAMPLE FORMAT OF AMC LOGPLAN.....	A-1
	B. CONTINGENCY OPERATIONS LOGISTICS CHECKLIST.....	B-1
	C. PRE-POSITIONED EMERGENCY SUPPLY PACKAGE LIST OF CLASS I, III, AND V REQUIREMENTS..	C-1
	D. DISASTER RELIEF SERVICES.....	D-1
	E. SAMPLE FORMAT OF REPORT OF OPERATIONS COSTS (US ARMY) TO ANNEX _____ (REPORTS) TO MACOM OPLAN.....	E-1
	F. LOGISTICS STATUS REPORT TO ANNEX _____ (REPORTS) TO MACOM OPLAN.....	F-1
	G. SUBMISSION OF MOVEMENT REQUIREMENTS TO ANNEX _____ (REPORTS) TO MACOM OPLAN ...	G-1
	H. UNIT MOVEMENT REPORT TO ANNEX _____ (REPORTS) TO MACOM OPLAN.....	H-1
	I. REFERENCES FOR FM 701-58.....	I-1
	J. DEFINITIONS AND ACRONYMS.....	J-1

CHAPTER 1

PURPOSE AND SCOPE

Section I. INTRODUCTION

1-1. Purpose

a. This manual describes Army doctrine for planning logistics support for emergency military operations at the major command and higher echelons of the Army logistics system. In concert with the how-to-fight manuals of the 100 series, the how-to-support manuals of the 63 series, FM 8-55, and the staff officers field manuals of the 101 series, this manual provides the doctrine for planning by the higher and supporting echelons to provide logistics support to the Army in the field. It is intended for use by commanders and staff officers at major echelons and planning agencies of Army component commands of unified commands, and of major Army commands (MACOMs) which provide logistics support to these Army component commands. It is to be used as a reference text for senior-level Army service schools and as a training text for logistics planning at major Army logistics commands.

b. The word "he," when used in this publication, refers to both the masculine and feminine genders, unless otherwise specifically stated.

c. Users of this publication are encouraged to submit recommended changes and comments to improve the publication. Comments should be keyed to the specific page, paragraph, and line of the text in which the change is recommended. Reasons will be provided for each comment to insure understanding and complete evaluation. Comments should be prepared using DA Form 2028 (Recommended Changes to Publications) and forwarded directly to Commandant, US Army Logistics Management Center, ATTN: AMXMC-LS, Fort Lee, Virginia 23801-6040.

1-2. Scope

This manual briefly describes principles and policies of logistics planning doctrine and some of the procedural aspects of implementation of the doctrine. It describes logistics planning to support various emergency plans; e.g., contingency, war emergency, force mobilization, continuity of operations, civil defense, disaster assistance, civil disturbance,

and others. The main elements of this manual are the responsibilities and activities of different echelons in developing plans. The manual begins with a discussion of the Department of Defense (DOD) strategic planning systems and guidance and the responsibilities of the Joint Chiefs of Staff (JCS). The Joint Operations Planning System (JOPS), the basis for planning military operations at the supported and supporting unified commands and their Army components and planning agencies are described in detail. The logistics support planning policies, procedures, and responsibilities of the Department of the Army (DA) Staff, MACOMs, the Defense Logistics Agency (DLA), General Services Administration (GSA), the Transportation Operating Agencies (TOA) (Military Traffic Management Command (MTMC), Military Airlift Command (MAC), Military Sealift Command (MSC)), and other activities which provide materiel support and other logistics support for the deployment and employment of Army forces for the conduct of military operations are discussed in the detail needed to provide an understanding of the overall planning process. Where needed, this includes the responsibilities of installation and unit commanders.

1-3. Logistics Principles

Many principles for providing logistics support have evolved from the history of war. Some of these principles are stated in JCS Pub 3, volume 1, *Joint Logistics Policy and Guidance*, Dr. James A. Huston's, *The Sinews of War: Army Logistics 1775-1953*, and other similar documents. The following logistics principles (not in order of significance) are especially applicable to planning the logistics support of military operations.

a. *Logistics Intelligence*. Effective logistics planning requires accurate and timely logistics information be acquired, analyzed, and made available to commanders at all levels in order to provide effective logistics support. The information process should engender a minimum of paper work and

transmit only the best and most accurate, relevant, and current information.

b. Objective. Logistics endeavors must be directed toward a clear and obtainable objective.

c. Generative Logistics. The professional application of initiative, knowledge, and the innovative exploration of technical and scientific advances are fundamental to the generation of logistics system improvements.

d. Interdependence. All functions of logistics are related to some degree. No one function of logistics can operate effectively without due consideration of the other functions.

e. Simplicity. It is essential at all levels of logistics that commanders create and use systems which are simple and direct. The life-cycle approach to materiel acquisition should stress sim-

plicity in materiel design as well as in the supporting structure.

f. Timeliness. Logistics support must be provided in the right quantity and at the proper time and place for accomplishment of the mission.

g. Forward Impetus. The impetus of logistics support is forward to support the combat mission. Supported commanders should be relieved of all possible details while retaining control of their own logistics support.

h. Cost-Effectiveness. Efficient management of logistics resources and austere programs are essential to effective logistics support.

i. Security. Security of every facet of the logistics system must be maintained to preserve resources and insure sustained combat capability.

Section II. MILITARY PLANNING

1-4. Staff Principles

a. Planning responsibilities, principles, authority, and functions discussed in this manual are in accordance with guidance published in JCS Pub 2, Unified Action Armed Forces (UNAAF); JCS Pub 3, volume V, JCS Pub 6; Joint Operations Planning System (JOPS); and FM 101-5, Staff Officers Field Manual, Staff Organization and Procedures. Of particular importance to all Army planners is the understanding of the principles and procedures of military problem solving and planning discussed in FM 101-5. These principles and procedures, as modified by other guidance documents such as the JOPS, provide the basis for planning logistics support.

b. Planning is a basic function of command. It may be expressed as an organized approach to future problems or the present design for future action. Planning delineates the means of going where you want to go from where you are. It answers in advance the questions of why, what, who, when, and how of future actions. Military planning will be discussed further in chapter 4.

1-5. Logistics Support Planning

a. Logistics plans are based on and designed to support the operational requirements of the com-

mand. For this reason logistics plans will differ in purpose, scope, timing, objectives, resources available, and detail. At the highest echelons of command, planning is conducted for the defense of national interests and selected national objectives. DOD, JCS, military services, and unified/specified commands have the responsibility of creating, employing, and supporting combat forces in furtherance of national objectives. This poses problems related to strategic planning, political contact, combat readiness, and combat effectiveness of forces and effective use of the Nation's economy to support the combat forces. At this level, planning is very complex and extends over a period of several years. As we proceed down the echelons of command, plans become more related to narrower specific objectives for achievement in decreasing time. They are more detailed and more susceptible to change.

b. Even though the command perspective may differ at various echelons, the principles and functions of command remain unchanged. There is an inseparable relationship between strategy, tactics, and logistics as shown in figure 1-1.

INTERRELATIONSHIPS OF STRATEGY, TACTICS AND LOGISTICS

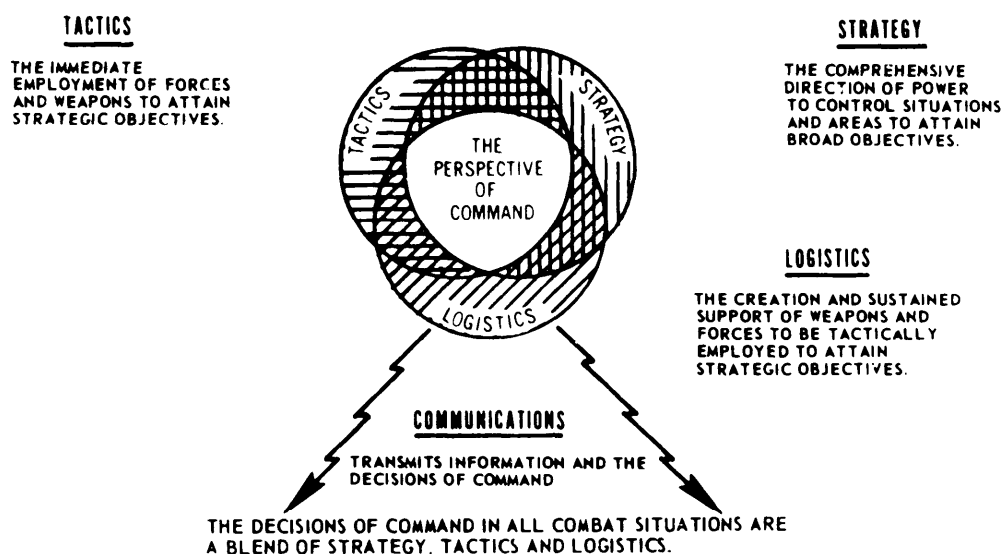

Figure 1-1. The interrelationships of strategy, tactics, and logistics.

c. Logistics plans provide the essential ingredients that make military operation plans workable. The essence of logistics planning involves the determination of supply, transportation, maintenance, construction, and related logistics requirements, and the determination of existing capability to meet these requirements. A comparative analysis is conducted to establish whether or not other limitations exist that may have a significant impact on the conduct of the mission. It is necessary to understand the following influences and basic considerations of logistics planning in the development of effective planning procedures.

(1) *Leadtime.* In general terms, leadtime is considered to be that time between action taken to obtain an item for use and arrival of the item in the hands of the user. Although the operational commander and his staff have little or no control over leadtime, they are vitally interested insofar as leadtime can and frequently does affect planning for the mission.

(2) *Limited Resources.* Resources (e.g., men, materiel, and money) are always limited. The concept of resources management promulgated by the DOD analysts recognizes this consideration by establishing throughout the Armed Forces a system for evaluating the essentiality of conflicting defense programs.

(3) *Critical Shortages.* This is a logistics planning problem which, historically speaking, we have always faced. The logistics planner and the

logistics system must expect that somewhere along the line a critical shortage will develop and that extraordinary and emergency measures must be taken to correct the shortage.

(4) *Priorities-Allocations-Reserves.* Since resources are always limited, systems of priorities and allocations are established reflecting command judgments of military value or essentiality. The basic point of this logistics consideration is that once a system is established, discipline is necessary to prevent frustration by well-meaning but unaware subordinates. In like manner, logistics reserves can only be used effectively with proper application of discipline exercised by command. Logistics reserves are as essential as personnel reserves in a tactical operation.

(5) *Coordination-Communication.* Constant exchange of information and coordination between operation and logistics planning are vital to the command so that all elements of command can bring about military success.

(6) *Flexibility.* Regardless of the level at which planning is conducted, it must provide for the means to be in place to carry out the commander's decision. The plan must also provide for enough flexibility to permit the commander and his staff to meet various situations that may arise as the result of enemy actions.

(7) *Adequacy-Suitability-Feasibility-Acceptability.* The courses of action open to a commander to

meet the situation which exists, or might develop, must be considered in terms of:

(a) Adequacy (accomplishment of the objective).

(b) Suitability (adaptable to various circumstances and appropriate to the threat).

(c) Feasibility (the ability to provide the right means at the right place at the right time, and in usable condition).

(d) Acceptability (e.g., affordability).

(8) *Command Control*. Each of the foregoing logistics considerations alludes to the key fact that command control must be exercised with sound judgment, understanding, competence, and restraint. Unless positive command control is maintained, the various logistics installations and operations tend to expand to unmanageable size.

d. To solve military problems successfully, the logistics planner must be skilled in the use of appropriate tools. Accurate, complete, and timely logistics information is one of the essential planning tools. Accepted planning factors are the means by which the logistician estimates the logistics requirements to support the tactical concept of an operation. Logistics estimates and logistics plans are, thus, dependent on the availability of readily usable information and planning factors and on the skill and judgment with which these are used by the planner.

(1) Planning factors are based on experience, either peacetime or wartime, and are used to forecast future requirements. Their accuracy will obviously vary as operating conditions change. AR 700-8, Logistics Planning Factors Management, assigns to the US Army Logistics Center of the US Army Training and Doctrine Command (TRADOC) the responsibility for the management of collection, development, maintenance, validation, and dissemination of Army logistics planning factors. These factors, maintained in a Logistics Factors File (LFF), are the foundation for logistics contingency/operational planning, force structuring, combat development studies, manpower criteria and Table of Organization and Equipment (TOE) development, budget analysis, transportation and training forecasts, and as input data for modeling and wargaming processes.

(2) Staff planning factors, while essential tools, should be used with a clear understanding of their capabilities and limitations. For example, a staff planning factor such as pounds per man per day

for ammunition expenditure by a tank battalion in an offensive operation normally would not be employed by planners on the division staff in estimating requirements for a specific operation. The reason, of course, is that this particular staff planning factor is broad and based on average conditions over a series of operations. While useful for long-range logistics planning at the corps or component force level, it may be inaccurate when applied to any particular operation. Detailed logistics requirements should, when practicable, be based on a thorough study of the specific operations to be conducted. This word of caution is particularly applicable to detailed requirements for ammunition; bulk petroleum, oil, and lubricant (POL); and equipment for all assigned forces.

(3) Logistics planners should accumulate new information within the area of operations, analyze it, and translate it into new planning factors which may supplement or replace older factors based on less recent experience. Normally, experience should soon build up planning factors which are either generally applicable or applicable to specific types of operations such as:

(a) Usage factors.

(b) Materiel losses.

(c) Transportation.

(d) Personnel casualty rates.

(e) Repair and maintenance requirements.

(f) Construction and facility development rates.

1-6. Summary

Planning is one of the most important functions of a logistician. The responsibilities for initiation, preparation, processing, and implementing have been described in general. It should be noted that involvement by all interested agencies should begin as early in the process as possible. It is also important that those affected be involved in the planning process. To be effective, each plan should reflect exactly what is expected to be accomplished at each echelon of an organization and when and by whom. It is important to remember that:

a. Planning cannot be accomplished in a vacuum.

b. Plans should be reviewed and updated continuously.

c. As data are refined, they should be included in the plans.

CHAPTER 2

ORGANIZATION FOR LOGISTICS SUPPORT

Section I. GENERAL

2-1. Introduction

a. Planning logistics support for military operations is a continuous, complex process. It evolves from objectives resulting from the threat analysis and decisions of the national command authority and the force structure designed to carry out US military policy. Logistics support planning is a function of command at each level. However, there are significant differences in interest at various levels of planning and in how planning is conducted and documented at different echelons. These will vary from broad, general terms to very specific detail and from present time to as much as 20 years in the future, depending on the level of organization and purpose of the planning. In general though, each plan fits into a bigger plan until the overall plan for national operations is reached. In the military this is accomplished within the framework of the Joint Strategic Planning System (JSPS) and the Planning, Programming, and Budgeting System (PPBS), which are explained in more detail in chapter 4.

b. In providing for logistics support of military operations, there are two kinds of logistics agencies within the organization to deal with.

(1) The top agency (the commander as the decisionmaker and his coordinating staff) is responsible for providing logistics policy and guidance; the review of requirements; the determination or approval of operational plans; and the determination and allocation of logistics means. These are the command aspects of the logistics functions and include the responsibility for planning and supervising the implementation of approved plans by all echelons.

(2) The implementing agency (the unit(s) subordinate to the top agency) executes its functions after the operation is approved. The top agency controls the approval of operational plans on the basis of the feasibility. The action of the implementing agency is always limited to the approved plans and subject to varying degrees of control by the top agency.

2-2. Levels of Planning

a. Planning systems employed at the highest echelons of command are designed to insure a disciplined approach to the formulation of military plans and programs for the defense of national interests and the achievement of selected national objectives. The Secretary of Defense, the Joint Chiefs of Staff (JCS), and military services relate war, mobilization, and budget plans to the national economy and to political factors. At this level, these efforts are frequently referred to as "mobilization" or strategic logistics planning and involve elaborate and complex processes as described in chapter 4. They consist of interdependent plans and programs extending over several years. The funds appropriated by Congress in response to these plans and programs determine the logistics capabilities of the Armed Forces and guide the development of broad strategic plans using the forces provided. National level planning also provides the basic policies and concepts for the equipping and support of the combat forces. At this level, emphasis is placed on the command aspects of the logistics function. Based on the threat analysis and the views of the President on foreign and national security policies, JCS prepares strategic plans and provides for the strategic direction of the Armed Forces. JCS, in addition to the proposals on military strategy, provides to the Office of the Secretary of Defense (OSD) proposals on force planning guidance. After considering these proposals and guidance from the President and other agencies, OSD provides planning and programming guidance which includes planning assumptions and guidelines for developing forces, logistics, manpower, research and development (R&D), telecommunications, and intelligence. From this the military departments develop their force levels, support and activity levels, and deployments with the constraints set by OSD. These submissions are reviewed by OSD and decisions are made on all special issues raised.

b. Military operations to further national strategic objectives are planned by the commanders of unified or specified commands who are responsible directly to the Secretary of Defense. Some of the command authority of the Secretary of Defense has been delegated to JCS, which provides strategic planning and direction to the commanders of the unified and specified commands. Tactical operations of the unified and specified commands are carried out by subunified commands or Joint Task Forces (JTF) made up of forces of two or more component services. Unless otherwise specified, logistics support for the service component is the responsibility of the parent service. The unified commander must insure the effectiveness and economy of the operations of assigned forces and prevent unnecessary duplication of equipment, facilities, services, supplies, and functions among the service components of his command. At this level, the commander is less intimate with the details of the tactical employment so planning is broad and generalized rather than detailed and exact. As the level of command at which the planning being conducted is lowered, the planning becomes more detailed.

c. At the unified/specified command level, force estimates and plans are developed to carry out US military strategy in assigned territorial areas of the world. The interests of the commander of the unified/specified commands span the time frames and strategic interests of JCS and the Secretary of Defense, and the operational and tactical interests of the subordinate commands. The unified commander provides to JCS force planning estimates

and other information regarding support of national military strategy. These cover the short-range and mid-range time frames and are used in developing the Five-Year Defense Program (FYDP) as part of the PPBS. He develops operation plans (OPLAN) and provides policy based on Department of Defense (DOD) and JCS guidance through which responsibilities are assigned and guidance is issued to the service component commands and subordinate, unified, or joint commands for development of their OPLANs for assigned missions. The military services, like DOD and JCS, are interested in the short, medium, and long range time frames and worldwide responsibilities. At the operational command level, the time frame narrows to hours or days at the lowest level. The area of territorial responsibility narrows to meters or kilometers. On the other hand, the expression of the concept of operations is quite specific and detailed. At the unified command level, the plans deal with the delivery of numbers of people without regard to rank and occupational specialty and tonnages of accompanying supplies and resupply that must be shipped to the theater within a scheduled period. The deploying units specify personnel by name, rank, serial number, and military occupational specialty (MOS), and accompanying supplies by quantity, nomenclature, and identification number. The military services determine personnel replacements by quantity and MOS and resupply by quantities of specific line items to support the operation. These differences in areas of interest are expressed in more detail in the paragraphs that follow and in chapters 7 through 9.

Section II. PLANNING RESPONSIBILITIES

2-3. National Command Authority

a. National security strategy is one of the key elements of the total national strategy. Assessment of the military threat to US national security and the estimation of the capabilities and intentions of potential and real opponents influence the formulation of the national security strategy and the force structure. Decisions relating to national security are ultimately the responsibility of the President. Since military strategy represents only one part of the total national strategy, the efforts in pursuit of this strategy must compete with other strategies dealing with foreign and domestic issues. To identify the major elements of these issues and strategies, a set of national programs has been developed. As with the various strategies, these programs compete with each other for order of importance and allocation of resources to carry

them out. The President, in his annual budget message to Congress, indicates the importance of, and assigns priorities to, the various programs needed to accomplish national objectives.

b. The President's leadership power in foreign policy and national security is vested in him by the Constitution. As Commander in Chief of the armed services, his role in national security strategy is clearly indicated. To provide the President with advice on domestic, foreign, and military policies relating to national security strategy, the National Security Council (NSC) was created by Congress in 1947. The current statutory membership of NSC includes the President, Vice President, Secretary of State, and Secretary of Defense. The Chairman of JCS, the Director of the Central Intelligence Agency (CIA), and other members of the Cabinet and Government officials may be invited

to participate uncertain sessions. NSC lacks executive authority and any other power except to offer advice to the President.

c. The function of NSC is to assist the President in integrating and implementing national security policy. Specifically, the council examines American national security goals in relation to national power; studies policies on matters of common interest to those departments and agencies concerned with national security; and suggests guidelines and courses of action to the President. These functions are carried out by several committees and supporting interdepartmental groups.

2-4. Department of Defense

a. The Department of Defense, created by the National Security Act of 1947, is the executive department most directly involved with conducting the national security affairs of the United States. DOD consists of OSD, JCS, the military departments and the military services, the unified and specified commands, and other defense agencies and activities established to meet specific requirements. The Secretary of Defense is the principal assistant to the President on all matters relating to national defense. He serves as a statutory member of the National Security Council, and members of his staff actively participate as members of the study groups and committees of the NSC. The secretary of Defense translates national security policy into plans, programs, organizational assignments, and implementing guidance for JCS, military departments, and DOD agencies and activities. The basic document which provides JCS and the military departments the basis for strategic military planning and operations is the Defense Guidance prepared annually by OSD. Logistics policies and guidance are contained in the Logistics Planning and Programming Guidance (LPPG) section of the Defense Guidance.

b. The basic objectives of DOD are to be prepared to support national policies, to defend successfully the security of the nation, and to insure the US readiness worldwide. To meet the needs of the United States and allied forces in a national emergency, an industrial base which can be quickly and effectively mobilized to support minimum essential long-range production requirements is of major importance. DOD has been charged with providing for a sustained state of industrial preparedness for production of essential military items through continuous planning for production.

2-5. Joint Chiefs of Staff

Planning by JCS includes both the "mobilization" or "warmaking" planning of OSD and the "oper-

ational" or "warfighting" planning of the operating forces. JCS is the principal military advisor to the President and the Secretary of Defense. The 31 December 1958 amendment to the National Security Act delineates the responsibilities of the military department, military services, and JCS and provides the basis for the establishment of unified and specified combatant commands. JCS is also an advisor to the National Security Council. Among the responsibilities assigned to JCS are those to provide the basis for JSPS and the Joint Operational Planning System (JOPS) described in detail in chapters 4 and 5. JCS is responsible for preparing strategic plans and providing strategic direction to the Armed Forces. Among the responsibilities assigned to JCS involving logistics planning are those to:

a. Prepare joint logistics plans and assign logistics responsibilities to the military services and the Defense Logistics Agency (DLA) in accordance with those plans.

b. Review major logistics requirements of the Armed Forces in relation to strategic and logistics plans.

c. Review and recommend to the Secretary of Defense appropriate logistics guidance for the military services which, if implemented, will result in logistics readiness consistent with the approved strategic plans.

d. Submit to the Secretary of Defense for information and consideration general strategic guidance for the development of industrial mobilization programs.

e. Prepare integrated plans for military mobilization.

f. Submit to the Secretary of Defense statements of military requirements based upon US strategic war plans. These statements include force requirements and general strategic guidance for the development of military installations and bases and for equipping and maintaining military forces.

g. Ascertain the logistics support available to execute the general war and contingency plans of the commanders of the unified and specified commands.

h. Provide logistics guidance for use by the military departments, the Armed Forces, and the defense agencies as needed in the preparation of their respective detailed plans.

i. Review the plans and programs of commanders of unified and specified commands to determine their adequacy, feasibility, and suitability for the performance of assigned missions.

2-6. Unified/Specified Commands

a. The US Military Establishment is an efficient team of land, naval, and air forces requiring close integration for effectiveness. The unity of effort required is achieved at the national level by the authority of the President and the Secretary of Defense, by the strategic planning and guidance of JCS and by the common, joint, and cross-servicing by the military departments. At the unified/specified command level, unity is achieved by exercise of operational command, by adherence to common strategic plans and directives and by a sound command organization. The chain of command for operational direction of combatant forces extends from the President to the Secretary of Defense, then through JCS to the commanders of the unified and specified commands. For purposes other than operational direction of unified and specified commands, the chain of command extends from the President to the Secretary of Defense to the Secretaries of the military departments.

b. Joint operations requirements include integration of effort of the assigned forces, planning for and conduct of operations, delineation of responsibilities, development of doctrine, and training of forces for joint operations. In operations of unified and specified commands, emphasis is on maximum integration of policies and procedures of assigned forces.

c. The unified and specified commands are involved in both the budgetary and mobilization level of planning, and the operational level. In the former, the unified and specified commands, based on assigned missions and territorial responsibilities, provide JCS with their "required" forces which are instrumental in developing the US Armed Force Structure. They also review plans of the service component commands to the military services to insure that the required resources are being provided and included in departmental budget submissions.

d. The unified and specified commanders prepare plans for operations within their areas of responsibility as directed by JCS and as determined to be necessary based on the commander's evaluation of the threat to US interests in their area of responsibility. Specifically, the unified/specified commander is authorized to "plan for, deploy, direct, control, and coordinate the action of assigned forces," and to "exercise directive authority within his command in the field of logistics." His authority extends also to other areas but that authority expressed above, as well as review of service component recommendations on budget submissions, are of primary interest to the logistics planner.

e. Operations planning at this level is quite detailed. Extensive use is made of the staff study, estimate of the situation, and operations analysis to provide the commander with that information which identifies several alternative courses of action, the advantages and disadvantages of each, and recommendations upon which the commander can base his decision. The operations planning process is formal and, in accordance with JOPS (discussed in detail in chapters 5 and 6), emphasizes the command aspects of planning. From this planning effort, guidance is provided to the service components, subordinate unified commands or JTF command, transportation operating agencies (TOA), and other supporting commands for development of their supporting plans. The logistics planning responsibilities of the unified/specified commander who develops the OPLAN (supported commander) and those of other unified/specified commanders, TOAs, and other major commands who support the OPLAN (supporting command) are discussed in chapter 5.

2-7. Department of the Army Planning

a. The Army planning system is oriented to the JSPS of JCS. It considers, as does JSPS, the short-term (0-2 years), midterm (2-10 years), and long-term (10-20 years) periods. The Army system has a formal cycle which causes a series of documents to be published. The series begins with critical strategic issues facing the Army, and an analysis of available appraisals and threat estimates related to strategic issues. The Army Strategic Appraisal (ASA) is the basis for developing Army positions on national strategy and policy. Developed by the Army War College, the ASA offers the Army Staff unconstrained views on critical strategic issues and suggests Army initiatives for addressing those issues. Primary planning guidance to the Army Staff and major commands from the Chief of Staff is contained in the Army Plan (TAP). The Army Mobilization and Operations Planning System (AMOPS) spells out for the Army Staff, Army major commands, and Army component commands of unified commands the guidance for employment and/or support of Army forces for this short-term period. This tells the Army component commanders of unified commands the Active Army units available for contingency planning, the mobilization schedule, and planned availability of Reserve component forces. It also assigns tasks to major Army commands (MACOM) and provides guidance for personnel, intelligence, and logistics matters; and provides guidance required to plan for mobilization of units and individuals to meet established force requirements in the event of the need to

expand the Active Army. DCSOPS, DA has Army General Staff responsibility for AMOPS.

b. The planning described above is directed primarily at budgeting and mobilization aspects. The DA Staff does not get actively involved in operational planning. Responsibilities for operational planning have been delegated to Army component and major commanders. The Army Staff does provide guidance, policy, and direction for planning. The Army Staff may become involved in operations planning on an exception basis and is responsible for periodically reviewing Army component commands' OPLANs. Logistics planning responsibilities of Headquarters, Department of the Army (HQDA) are discussed further in chapter 7. The responsibilities of other major commands are discussed in chapters 7 and 8.

2-8. Non-Department of Defense Agencies

Several departments and agencies, other than DOD, have responsibilities which contribute to the logistics support of the military forces. The principal agencies and their contributions are:

a. Department of Commerce. This department is concerned with promoting the nation's economic development and technological advancement. Among its programs are the provision of social and economic statistics and analyses for business and Government planners; increased use of science and technology in development of the economy; and understanding of the earth's physical environment and oceanic life. The functions of this activity are of special interest to military logistics planners. The National Oceanic and Atmospheric Administration (NOAA) falls under this department. The principal functions and activities of NOAA are:

(1) Reporting the weather of the United States and its possessions to provide weather forecasts and issues warnings against destructive natural events, and provide special services to weather-sensitive activities.

(2) Preparing and issuing nautical and aeronautical charts and providing precise geodetic surveys.

(3) Predicting tides, currents, and the state of oceans.

(4) Operating a national environmental satellite system.

(5) Acquiring, storing, and disseminating worldwide environmental data through a system of meteorological, oceanographic, geodetic, and seismological centers.

b. Department of Transportation (DOT).

(1) DOT is responsible for the development of national transportation policies and programs conducive to the provision of fast, safe, efficient, and convenient transportation at the lowest possible cost. It coordinates many transportation services and encourages the cooperation of Federal, State, and local Government transportation activities as well as pertinent industry and labor groups. The Federal Aviation, Highway, and Railroad Administrations are the important elements of DOT that, among other responsibilities, make rules and establish systems to insure the safety of these modes of transportation. DOT is also responsible for the development and maintenance of the US Merchant Marine.

(2) Transportation planning for national emergencies is centrally coordinated by the Director of Emergency Transportation of DOT. The mission of this office is to prepare a national emergency plan and develop preparedness programs covering all modes of commercial transportation for the movement of passenger and freight traffic to meet essential civil and military needs during an emergency. In a national emergency, this office is responsible for coordinating transportation requirements of various agencies, allocating commercial transportation resources including intransit storage facilities, and providing the administrative capability for guiding and controlling all commercial transportation.

(3) The Maritime Administration administers programs that aid in the development, promotion, and operation of the US Merchant Marine. The administration conducts research and development activities to improve the efficiency and economy of the Merchant Marine. Under emergency conditions, it charters Government-owned ships to US operators; requisitions or procures ships owned by US citizens; and allocates them to meet defense needs. It maintains a National Defense Reserve Fleet of Government-owned ships which it operates through general agents when required in national defense interests. It also disposes of Government-owned ships not essential to national defense needs.

c. General Services Administration (GSA). The GSA provides a range of services to DOD and other Government agencies. These services include automatic data processing (ADP) resources management; the Federal Telecommunications System (FTS); and a Government-wide supply and service system (see also paragraph 6-16). Within GSA, two major subordinate elements are of special interest to DOD logistics planners.

(1) The Office of Information Resources Management is responsible for the ADP Resources Management Program and the FTS which is composed of the FTS Voice Network and the Data/Record Network.

(2) The Office of Federal Supply and Services operates a Government-wide system to provide common services and supplies. It is also responsible for managing most emergency defense supplies. During a national defense emergency, requisitions are submitted to GSA in the normal manner. When serious shortages or other developments require changes in supply methods or procedures, GSA will issue further guidance. In the event that the United States is involved in an overseas conflict, Federal agencies could be operating under emergency conditions for a prolonged period. The GSA emergency preparedness plans provide for inventory buildups, expedited deliveries from suppliers, and the execution of new

supply contracts as required, as a means for satisfying the expected increase in requirements. This is particularly significant for items supplied to DOD activities and associated agencies (CIA, National Aeronautics and Space Administration (NASA), Federal Aviation Administration (FAA), and Nuclear Regulatory Commission (NRC)).

d. Federal Emergency Management Agency (FEMA). FEMA was created to provide a single point of accountability for all Federal emergency preparedness, mitigation, and response activities. The Agency is chartered to enhance the multiple use of emergency preparedness and response resources at the Federal, State, and local levels of Government in preparing for and responding to the full range of emergencies—natural, manmade, and nuclear—and to integrate into a comprehensive framework activities concerned with hazard mitigation, preparedness planning, relief operations, and recovery assistance.

Section III. LOGISTICS SUPPORT RESPONSIBILITIES

2-9. Department of Defense Agencies

a. Under Secretary of Defense for Research and Engineering (USDRE). USDRE serves as the principal advisor and staff assistant to the Secretary of Defense for scientific and technical matters, basic and applied research, environmental sciences, and the development of weapon systems. USDRE must insure complete coordination between the military departments as well as with JCS on the interaction of strategy and research and development. He must monitor system development and provide the necessary policies and guidance with respect to types of R&D effort and specific systems and equipments.

b. The Assistant Secretary of Defense (Acquisition and Logistics) (ASD(A&L)). ASD(A&L) is the principal logistics staff office in the Office of the Secretary of Defense. In the logistics area, he is involved in the fields of weapon system acquisition, acquisition management, industrial base and resources, supply management, transportation and traffic management, production and manufacturing, contract provisions and administration, spares program management, industrial priorities and allocation system and, in coordination with the Under Secretary of Defense (Research and Engineering), the functional area of Integrated Logistics Support (ILS). Other responsibilities of the Department include installations and real property planning, design, acquisition, maintenance, and disposal; military base structure and utilization; facilities readiness and sustainability; and military

mobilization planning guidance for installations and logistics. As the designated Defense Acquisition Executive, ASD(A&L) also serves as the principal advisor and staff assistant to the Secretary of Defense for the acquisition of defense systems and equipment.

c. Assistant Secretary of Defense (Force Management and Personnel) (ASD(FM&P)). The ASD(FM&P) serves as the principal staff assistant and advisor to the Secretary of Defense for total force management, military and civilian manpower, military and civilian personnel matters, and manpower requirements for weapons support.

d. Director of Program Analysis and Evaluation. This director serves as the principal advisor and staff assistant to the Secretary of Defense in the area of operational test and evaluation of weapons systems and defense materiel.

e. Defense Logistics Agency.

(1) DLA is a DOD agency under the Secretary of Defense and subject to DOD policies, directives, and instructions. The DLA mission is to:

(a) provide effective and economical support to the military services, other DOD components, Federal civil agencies, foreign governments, and others as authorized, for assigned materiel commodities and items of supply, logistics directly associated with the supply management function, and other support services as directed by the Secretary of Defense;

(b) provide contract administration services to the military departments and other DOD components, Federal civil agencies and, when authorized, to foreign governments and others; and

(c) administer the operation of DOD programs as assigned.

(2) DLA is also responsible for the performance of the following functions—materiel management, technical report services, monitoring DOD supply relationships with General Services Administration, operating a centralized referral system for DOD employees, and monitoring systems analysis and design, procedural development, and maintenance for supply and service systems as assigned by the Secretary of Defense.

(3) In the area of logistics services, DLA handles the administration of a variety of Department of Defense programs related to the logistics mission, among them, the Federal Catalog System, the Defense Integrated Data System, the Research and Technology Information System, the DOD Personal Property Utilization and Disposal Program, the Defense Industrial Plant Equipment Program, and the Defense Precious Metals Recovery Program. Besides these broad programs, the logistics services category includes a wide range of more specific administrative and technical services, from housekeeping and office support to operation of a vast supply management data bank.

f. The Joint Chiefs of Staff. (See paragraph 2-5.)

g. Unified/Specified Commands. (See paragraph 2-6.)

h. Component Commands.

(1) A component command consists of the component commander and all those individuals, units, detachments, organizations, or installations under his military command which have been assigned to the operational command of the commander of the unified command. Other individuals, units, detachments, organizations, or installations may operate directly under the component commander in his service role, and should contribute to the mission of the unified commander as appropriate.

(2) Each component commander is charged with the responsibility for making recommendations to the commander of the unified command on the proper employment of his component, and for accomplishing such operational missions as may be assigned by the commander of the unified command. The component commander is responsible within his command for:

(a) Internal administration and discipline, except as may be otherwise provided.

(b) Training in own service doctrine, techniques, and tactical methods.

(c) Logistics functions normal to the component except as otherwise directed by higher authority or herein.

(d) Tactical employment of the forces of his component.

(e) Service intelligence matters.

(3) The component commander communicates directly with his Chief of Service on uniservice matters relating to administration, personnel, training (US and allied), logistics, communications, doctrine, and combat development, and other matters when of uniservice interest. Where intelligence matters are of uniservice interest, he will communicate directly with his Chief of Service.

(4) The component commander is responsible to the commander of the unified command for the conduct of training, as directed, of elements of the other services in:

(a) Joint operations for which his own service has been or may be assigned primary responsibility.

(b) Operations for which his facilities and capabilities are suitable.

i. Joint Task Forces.

(1) A joint task force is a force composed of assigned or attached elements of the Army, the Navy, the Marine Corps, and the Air Force, or two or more of these services, which is constituted and so designated by the Secretary of Defense or by the commander of a unified command, a specified command, or an existing joint task force. A joint task force, unlike a subordinate unified command, is not a permanent command arrangement, but is dissolved when the purpose for which it was created has been achieved. It is established when the mission to be accomplished has a specific limited objective, and:

(a) Requires execution of responsibilities involving two or more services on a significant scale, and close integration of effort.

(b) Requires coordination within a subordinate area or of its local defense.

(c) Does not require overall centralized direction of logistics.

(2) The commander of a joint task force exercises operational command over his entire force. He also may exercise direct command of his own service component.

(3) A commander of a joint task force exercises logistics coordination or control only to the extent

necessary to meet those logistics needs of the subordinate commanders which are essential to the successful accomplishment of his missions, and to meet any request of the subordinate commanders for logistics support.

j. Uniservice Force. Used in the sense of a command subordinate to a unified commander, a uniservice force is a force composed of significant elements of one service, the commander of which reports directly to the unified commander rather than through the appropriate service component commander. Normally, missions requiring operations of a uniservice force will be assigned to the component commander of that service.

k. Subordinate Unified Command. The criteria for the establishment of a subordinate unified command, and the definition, are the same as those for the unified command. The commander of a unified command is authorized to establish subordinate unified commands subject to approval of JCS. The commander of a subordinate unified command within his area of responsibility and subject to modification by the authority appointing him to such command has functions, authorities, and responsibilities similar to those of the commander of a unified command established by the President.

However, commanders of service components of subordinate unified commands will communicate directly with the commanders of the service components of the unified command on matters which are the responsibility of the military departments and services, or as directed by their Chief of Service.

l. Transportation Operating Agencies. The Secretary of Defense has established agencies to furnish specific types of transportation support across DOD. The Military Traffic Management Command (MTMC), the Military Sealift Command (MSC), and the Military Airlift Command (MAC) are single managers charged with the provisioning of transportation services concomitant with their normal operational environment. A detailed description of their functions is contained in paragraph 6-17.

2-10. Department of the Army Organizations

a. Figure 2-1 shows the major organizations within DA that are concerned with our logistics system. Of prime concern in this manual is the Army Staff, US Army Materiel Command (AMC), and Army-in-the-field logistical organizations.

**Organization of the Department of the Army
(LOGISTICS)**

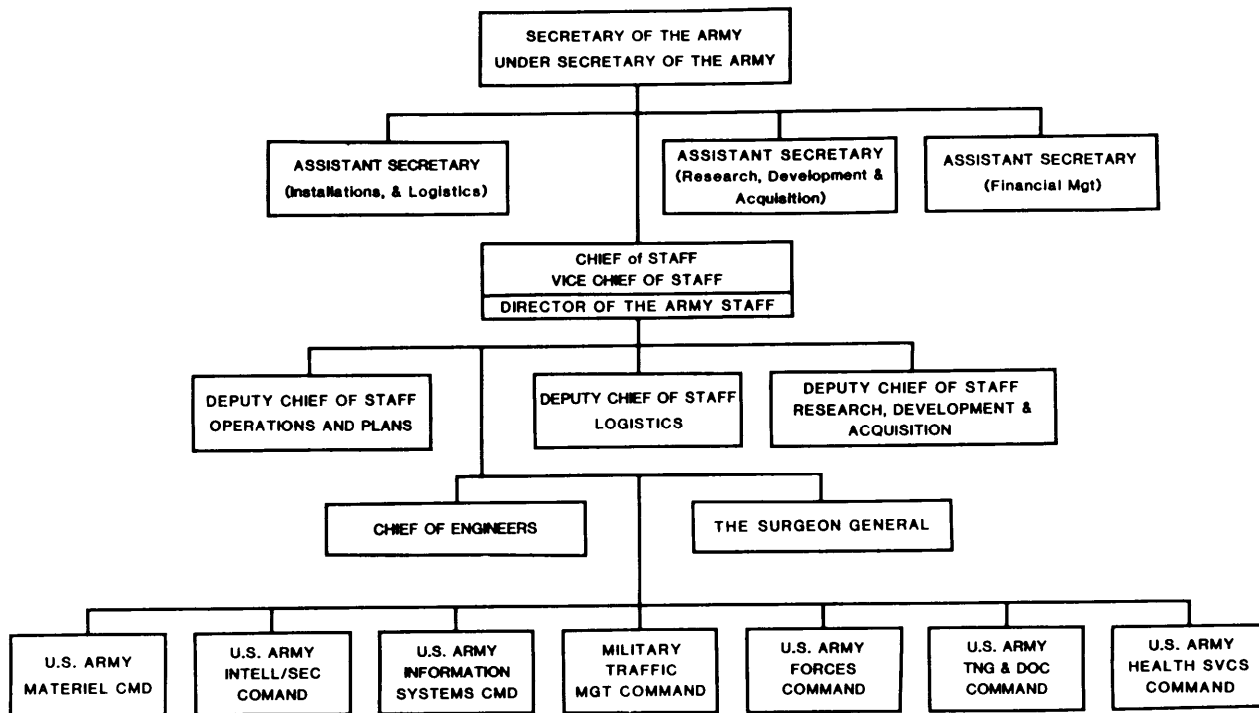

NOTE: Does not include all MACOMs.

FIGURE 2-1. DA organization for logistics.

b. The following DA Staff members have a major impact on the Army logistics system.

(1) The Secretary of the Army is the head of the Department of the Army. Subject to the direction, authority, and control of the President as Commander in Chief and of the Secretary of Defense, the Secretary of the Army is responsible for and has the authority to conduct all affairs of the Department of the Army, including, but not limited to, those necessary or appropriate for training operations, administration, logistical support and maintenance, welfare, preparedness, and effectiveness of the Army, including research and development, and such other activities as may be prescribed by the President or the Secretary of Defense as authorized by law.

(2) Subject to the direction and control of the Secretary of the Army, the Assistant Secretary of the Army (Installations and Logistics) is authorized and directed to act for the Secretary of the Army in the following fields: materiel requirements, procurement and production, and materiel management and logistics service. He is also responsible for installation planning and program-

ing; and facilities and real property management and construction.

(3) The Assistant Secretary of the Army (Research, Development, and Acquisition) is responsible for research and development including basic and applied research; RDTE of weapons, weapons systems and Army materiel; RDTE acquisition, integration of technology with military requirements; Army scientific Advisory Panel matters; mapping and geodetic programs; and coordination of all research, development and acquisition matters with DOD, other military departments, and other agencies outside DOD.

(4) The Army Staff is defined as that portion of the staff of the Secretary of the Army at the seat of Government which is presided over by the Chief of Staff. The Army Staff assists the Secretary of the Army in the conduct of long-range planning, resource determination and allocation, the development of Army-wide objectives, the formulation of broad policy guidance, and the supervision and control of operations. Elements of the Army Staff, under the direction of the Chief of Staff, provide both for the specialized knowledge of the various fields of Army activity and for the

coordination of these activities into a homogeneous, consistent, unified Army effort which will mesh efficiently with the efforts of all other elements of DOD. The principal members of the Army Staff that have a major impact on our logistics system are:

(a) *Deputy Chief of Staff for Operations and Plans.* DCSOPS has Army General Staff responsibility for strategy formulation, overall force development and the establishment of requirements and priorities for, and the utilization of, Army forces. He is the principal adviser to the Chief of Staff on joint matters, National Security Council matters, security assistance matters, and the politico-military aspects of international affairs. He also has primary staff responsibility for maintaining the Structure and Composition System (SACS) file which lists Army-wide personnel and equipment authorizations.

(b) *Deputy Chief of Staff for Logistics (DCSLOG).* DCSLOG has Army General Staff responsibility for the management of DA logistical activities. Responsibilities include Active and Reserve Component logistics. The DCSLOG is responsible for the development and supervision of Army logistics organization, operations, and systems worldwide, including logistics readiness, planning, policies, doctrine, resource determination and allocation, integrated logistics support and competition contracting, objectives, force structure, and standards. His major functions include supply, maintenance, transportation, the Army energy program, troop support activities and acting as the principal Army staff representative and focal point for security assistance matters. The DCSLOG is Director of the Army Stock Fund and Army Industrial Fund, Program Director for FYDP Programs 4, 7, and 11, Program Director for Base Operations Administrative Program, Budget Program Director for Military Assistance Program Supply Operations, Budget Appropriation Director and Manager of Foreign Military Sales Administrative Fee Funds, and Appropriation Director for the Trust Revolving Fund Account (Commissary Surcharge). The DCSLOG participates in and contributes to all phases of the research, development, and acquisition process (concept through deployment) and is responsible for support of materiel systems from production output through disposal. The DCSLOG chairs the Army Logistics Policy Committee, Logistics Center Advisory Board, and is DOD Executive Agent for Worldwide Military Customs Inspection Program. The DCSLOG supervises and controls the US Army Troop Support Agency and the US Army Logistics Evaluation Agency.

(c) *Deputy Chief of Staff for Personnel (DCSPER).* DCSPER has Army General Staff responsibility for plans, policies, and programs for manpower authorizations and the management of military personnel of all components of the Army on active duty; of Reserve component individuals not on active duty; of the ROTC; and of DA civilian personnel. He is agent for the Army portion of the DOD appropriation for Retired Pay and Claims. He is the DOD Executive Agent for the Defense Language Institute and the Defense Information School and, on behalf of the Secretary of the Army, acts as Executive Agent for DOD for the administration of the DOD Enemy Prisoner of War/Detainee Program. He is responsible for Army Staff functions regarding law enforcement, criminal investigations, physical security, and confinement and correction of military prisoners; for Army research and development related to training, personnel and manpower systems, human factors, equal opportunity and race relations programs, and organizational effectiveness activities. He is responsible for life-cycle management of initial clothing allowance items (uniforms). He is functional chief of the civilian career program in manpower management and civilian personnel administration. He is a member of the Army Policy Council, the General Staff Council, and the Select Committee.

(d) *Chief of Engineers.* The Chief of Engineers serves as the principal adviser to the Chief of Staff for engineering matters and is responsible to the Secretary of the Army for prescribed civil works functions. He is the Director of the Military Construction, Army; Homeowners Assistance; and Family Housing Appropriations. He is responsible for the life-cycle management of real property to include base development planning.

(e) *The Surgeon General.* The Surgeon General is the principal adviser to the Chief of Staff for all health and medical matters pertaining to the Army. Under the guidance and supervision of designated Army General Staff agencies, The Surgeon General has Army Staff responsibility for the management of health services for the Army and, as directed, for other services, agencies, and organizations. He is responsible for the management of all medical materiel required for the support of Army forces to include both supply and maintenance actions.

(5) *DA Staff Support Agencies.* DA Staff Support Agencies exist primarily to provide specialized staff services to the Army Staff. The Staff Support Agency with significant logistical responsibilities is the Engineer Studies Group (ESG).

ESG, under the staff control of the Chief of Engineers, has the primary mission of preparing analyses and studies to assist the Army Staff in making decisions in the area of real property facilities planning. Its major logistical mission has been the development of base development plans for major theaters of operation and also the publication of base development planning guides to assist staff planners.

(6) *DA Field Operating Agencies.* These agencies execute policy developed by the Army Staff. Major Field Operating Agencies with a significant logistical mission are:

(a) *US Army Troop Support Agency (TSA)* TSA, under the direction of the DCSLOG, commands and controls all Army commissaries and provides technical assistance and standardized procedures for worldwide operation of the Army Food Program, to include food service, troop issue subsistence activities, and field bakeries; also for laundry and dry cleaning activities, clothing sales stores, clothing initial issue points, field laundry and operations. TSA is located at Fort Lee, Virginia.

(b) *US Army Medical Materiel Agency (USAMMA).* USAMMA functions as the Service Item Control Center (SICC) for medical equipment and supplies, including dental and veterinary; serves as the developer for functional systems for medical materiel management and biomedical equipment maintenance; provides technical assistance Army-wide to resolve medical materiel problems; operates the Army Medical Department (AMEDD) National Maintenance Point; provides depot-level maintenance support for medical materiel; manages the AMEDD major medical assemblage program; provides life cycle management of medical materiel for full application; and manages the Medical Care Support Equipment Program. USAMMA is located at Fort Detrick, Maryland.

(c) *US Army Logistics Evaluation Agency (LEA).* LEA, under control of DCSLOG, is responsible for central direction and control of the development and maintenance of the Army logistics system, analysis of logistics doctrine, organization and systems, evaluation of the logistics portions of contingency plans, and for representing the logistician during the life-cycle development of new materiel. LEA is located at New Cumberland Army Depot.

c. The logistics responsibility of major DA commands is as follows:

(1) The Commander, US Army Training and Doctrine Command (TRADOC), develops, manages, and supervises the training of individuals of the

Active Army and Reserve components. He also formulates and documents concepts, doctrine, materiel requirements, organizations, and appropriate systems for the Army in all environments, tactical and nontactical. He commands subordinate commands, installations, and activities as may be assigned by HQDA and, as directed, provides administrative and logistical support through his subordinate installation commanders to other DA, DOD, or Government agencies.

(a) The CG, TRADOC has responsibilities in four general functional areas: doctrine developments, combat developments, training systems and as commander of a major Army command. To assist TRADOC in the first three mission areas, the CG has three integrating centers (Combined Arms Center, Logistics Center, and Soldier Support Center). Under each of these Centers lies the branch centers, specialist centers, and schools which are generally responsible for doctrinal development and branch training.

(b) Of the three integrating centers, the US Army Logistics Center is responsible for developing and evaluating logistics concepts, doctrine, organizations, systems, materiel concepts, and requirements, and planning factors for the Army. Included is the task of insuring that the supply, maintenance, transportation, services, and facilities systems designed for the Army in the field and the CONUS retail logistics system are compatible with the wholesale logistics system.

(2) The Commander, US Army Forces Command (FORSCOM), commands all assigned Active Army forces in the United States, the United States armies, and the United States Army Reserve within the United States. He serves as Commander in Chief, United States Army Forces Readiness Command and, for planning purposes, as Commander in Chief, United States Army Forces Atlantic Command. He also commands those subordinate commands, installations, and activities assigned by HQDA and, as directed, provides administrative and logistical support through his subordinate installation commanders to DA, DOD, or other Government agencies. In addition, he supervises the training of Army National Guard units within CONUS, the Commonwealth of Puerto Rico, and the Virgin Islands of the United States. The commander of each of the United States armies has the primary mission, under the Commander, FORSCOM, to command the United States Army Reserve, plan for mobilization, coordinate domestic emergencies, and exercise training supervision over the Army National Guard.

(3) The Commander, United States Army Health Services Command, performs health services for the Army within CONUS, and as directed, for other governmental agencies and activities. He commands the Army hospital system within CONUS and other organizations, units, and facilities as may be directed. He is responsible for the conduct of health service support of professional education for Army personnel. He is further responsible, under the guidance of the Commander, TRADOC, for the development of medical doctrine, concepts, organizations, materiel requirements, and systems in support of the Army.

(4) The Commander, United States Army Information Systems Command (USAISC), is responsible to engineer and implement integrated Army information systems; plan, engineer, acquire, install, test, operate, and maintain assigned Army information systems, to include Army's part of the Defense Communications System (DCS) and Army's Air Traffic Control (ATC) system, to include EAC C-E systems, and provide new equipment training for such systems; perform acquisition management functions for assigned Army information systems for DCS, Army, freed Army ATC facilities/stations, base communications (BASECOM), echelons above corps (EAC) level information systems, automation systems at Corps and below, and provide audiovisual support. His logistics responsibilities include providing logistics management and control of materiel and facility resources acquired solely to provide fixed or strategic communications for the DCS (Army) and other Army information systems as assigned; developing the Five-Year Materiel Requirement Program for mission-peculiar equipment and information systems equipment; providing organizational, direct support (DS), general support (GS), maintenance for assigned information systems equipment; providing communications security (COMSEC) logistics support to Army components of unified or specified commands; participating in combat development of COMSEC logistics for Army in the field and performing operational and development test and evaluation of COMSEC equipment.

(5) The Commander, Military Traffic Management Command, see paragraph 6-17.

(6) The Commander, AMC, commands various military installations and separate units which operate the wholesale segment of the Army Logistics System through subordinate commands. He directs the activities of depots, laboratories, arsenals, maintenance shops, proving grounds, test ranges, Logistics Assistance Offices (LAOs), and procurement offices throughout the United States. The present AMC organization includes six commodity-

oriented research and development commands, two commodity-oriented readiness commands, three combined commands, the US Army Test and Evaluation Command (TECOM), the US Army Depot System Command (DESCOM), and the US Army Security Assistance Center (USASAC). AMC headquarters furnishes overall policy guidance for its operations. The major subordinate commands serve as the "mid-management level." Individual installations and activities accomplish the actual execution of the Army's materiel program. (See also chapter 7.)

d. Installation commanders provide logistical support to assigned units and activities at CONUS installations, or their oversea equivalent. Installation level logistics is characterized by the fixed nature of logistical support activities found at posts, camps, and stations (e.g., post maintenance shops, post transportation motor pools). Normally, the control of logistical support activities on an installation rests with the installation commander, who is appointed by the MACOM that commands that post. At many CONUS installations, two or more MACOMs may have activities at the same post in which case the dominant command will control the post. The dominant command is responsible for logistical support of the installation and receives logistics resources from activities of other MACOMs located on that post. At most CONUS installations, FORSCOM or TRADOC will be the dominant activity and will control the installation. However, several CONUS installations are controlled by other MACOMs such as AMC or the Health Services Command.

e. Army component commanders and Army tactical commanders operate the Army-in-the-field segment of the Army Logistics System. The Army-in-the-field segment consists primarily of those combat service support units which are organic to operating forces in an oversea theater of operations. However, a limited number of Army-in-the-field units are located in CONUS to support contingency operations. The composition of the Army-in-the-field logistics system may vary greatly from one theater to another based on the supply, maintenance, and transportation policies. Current doctrine attempts to establish a system which is flexible enough to be tailored to any given theater but which insures that logistical functions are provided in the degree required. A representative theater Army command is shown in figure 2-2.

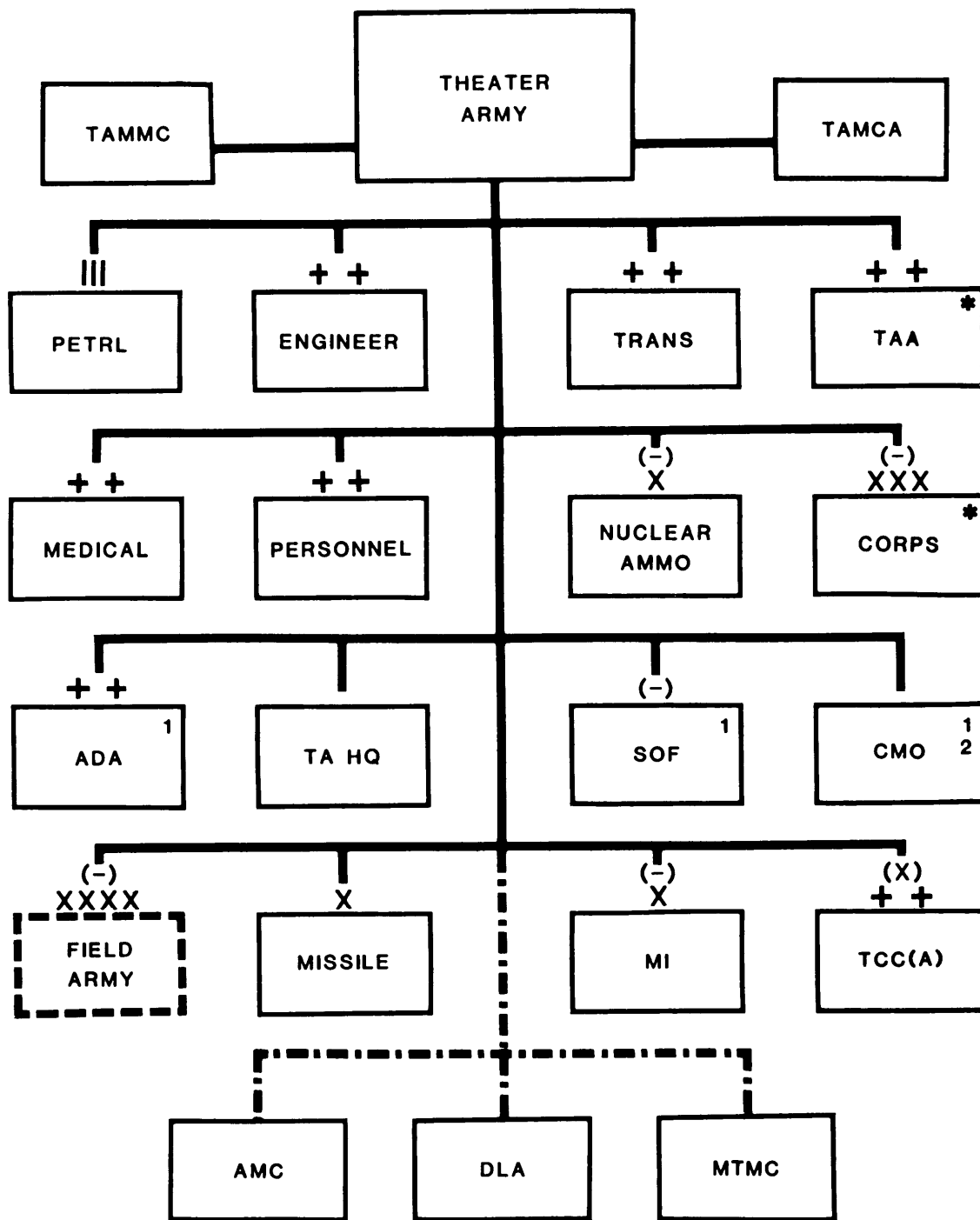

LEGEND

— COMMAND

—(-)— COMMAND LESS OPCON

—(X)— OPERATIONAL CONTROL

—(X-)— OPCON LESS SPECIFIC FUNCTIONS

* VARIABLE NUMBER AS REQUIRED

--- RELATIONSHIP ESTABLISHED BY MOA

--- ASSIGNED/ATTACHED AS REQUIRED

1 SIZE OF UNIT WILL BE DEPENDENT ON MISSION

2 CMO INCLUDE THE CIVIL AFFAIRS AND PSYCHOLOGICAL OPERATIONS ELEMENTS

Figure 2-2. Theater Army Organization (mature)

(1) The combat service support mission of a US theater Army is to:

(a) Organize and operate the necessary services for combat service support of US Army forces in the theater. This entails long-range planning, estimates of personnel and logistics requirements, and efficient use of resources. It requires close liaison with collateral and higher headquarters and the commands directly subordinate to US theater Army.

(b) Provide common supply items and common services to other US service elements and allies in the theater as provided for by agreements or assignments.

(c) Provide combat service support to civilian and other agencies and forces as directed.

(d) Allocate critical and regulated items of supply.

(2) The theater Army commander retains overall control of combat service support operations to insure uniformity of the support effort in the combat zone and in the Communications Zone (COMMZ). The commander exercises control through promulgation of appropriate policies, mission directives, broad planning and program guidance, allocations, and priorities for accomplishing the theater Army mission.

(3) In some conflicts, the theater of operations may be smaller than that implied in (1), above. In such cases, the Army component of the theater may consist of a single corps or a smaller force. The concepts of organization, mission, and functions outlined above are applicable to the smaller theater, modified as necessary to satisfy its requirements. When a corps is the major Army component of a theater, its corps support command (COSCOM) will be tailored to provide the theater Army base activities normally provided by the major functional and area commands of TA. When corps headquarters has theater Army responsibilities, it is, in effect, the Army component command.

(4) The major functional and area commands of TA consist of five logistic commands and the Theater Communications Command (Army) (TCC(A)). In addition, a Civil Affairs (CA) Command may be included. The commands and their mission are:

(a) *Personnel Command (PERSCOM)*. PERSCOM directs, coordinates, and provides DS/GS personnel services, administrative management, morale support activities, postal services, enemy prisoner of war confinement, and control and confinement of US military prisoners to the theater.

(b) *Medical Command (MEDCOM)*. MEDCOM is the senior medical command and control headquarters for the Communications Zone (COMMZ) medical units and activities that provide theater-wide Health Service Support (HSS). The MEDCOM does not exercise command and control of Combat Zone (CZ) medical units, but does provide technical advice and guidance (through the Theater Army Surgeon), and is generally organized to facilitate reallocation of COMMZ assets to the CZ to accommodate patient workload and reconstitute CZ medical units. The Medical Command provides:

1 Centralized command and control of all health service support functions and operations within the communications zone.

2 Health service support on an area basis to Army and other designated forces in the COMMZ.

3 Support to the combat zone consisting of receiving patients evacuated from corps areas to the COMMZ.

4 Backup support to the combat zone health service support system.

(c) *Transportation Command (TRANSCOM)*. TRANSCOM provides Army transportation services to a theater of operations. TRANSCOM provides combat service support in four functional areas: staff assistance, transportation coordination, mode operations, and terminal services.

(d) *Engineer Command (ENCOM)*. ENCOM provides general troop and contractual construction support, topographic support, and real property maintenance activities (RPMA) to the Army and other services and allies within the COMMZ; and support to the corps on a task basis, as required.

(e) *Theater Army Area Command (TAACOM)*. The TAACOM has three missions. The first is to provide direct CSS, less movement control and line haul transportation, to units located in or passing through its assigned area. This includes personnel and administration support, intermediate (direct support) maintenance, the provision of most classes of supply (exceptions being nuclear ammunition and Class VIII), DS- and GS-level field services, local transportation, and contracting support. The second mission is to support the Corps with specified logistics support and the overall theater supply system with intermediate (general support) maintenance in support of the supply system. The third mission is geographical in that the TAACOM is responsible for rear area protection within its assigned area.

(f) *Theater Communications Command (Army) (TCC(A))*. TCC(A) installs, operates and maintains information systems which provide command and area coverage of EAC headquarters, units, and installations.

(g) *Civil Affairs (CA) Command*. The CA command may be employed to exercise command and control (centralized execution) or command less operational control (decentralized control) over CA commands operating in the COMMZ.

(5) In the combat zone:

(a) The employment of numbered armies is an exception but may be necessary in wartime in a large theater of operations where the land force structure reaches a magnitude that requires an intermediate control unit between the theater commander and the corps. In small theaters, the largest land force element may be a single corps. When used, the numbered Army directs the strategic and tactical operations of multiple corps. Operational control of the numbered army may be exercised by the theater/unified commander or the theater Army commander.

(b) The numbered Army normally does not operate combat service support installations. It does, however:

1 Establish priorities for supplies for its assigned and attached troops.

2 Establish priorities for movements.

3 Establish priorities for the allocation of replacements to its major subordinate commands.

4 Allocate available service troops to its major subordinate commands.

5 Normally control allocation of ammunition to its major subordinate commands and may control allocation of other items and services in accordance with assigned tactical missions.

6 Determine the adequacy of support to subordinate units by supporting theater Army commands.

7 Estimate overall combat service support troop and supply requirements to support operations and make recommendations to the theater Army commander for the allocation of appropriate resources.

8 Assign territorial responsibilities to subordinate corps.

9 Supervise and coordinate the CA activities of subordinate and supporting units.

(c) The corps is the largest self-contained US Army organization that has combat, combat support, and combat service support functions. It consists of a headquarters; a COSCOM; a variable number of divisions; and other units, such as artillery, signal, military police, and engineer. The corps commander is responsible for the organization and operation of services necessary to the immediate support of units in the corps. This requires long-range planning, preparation of detailed estimates of combat service support needs, and close liaison with other major commands.

1 COSCOM is the logistics element of the corps. It normally supports a corps with a headquarters and associated functional control centers, materiel management center (MMC), and a movement control center (MCC). The organization of COSCOM is tailored on a company building block basis to fit its mission requirements. A COSCOM normally includes two or more support groups, an ammunition group, transportation brigade, petroleum supply battalion, materiel management center, movement control center, and explosive ordnance control center. A civil affairs and/or chemical unit may be assigned to the COSCOM or corps. In an arid environment, a water supply battalion may be provided. Figure 2-3 shows the organization of a COSCOM. (FM 63-3J contains details on COSCOM.)

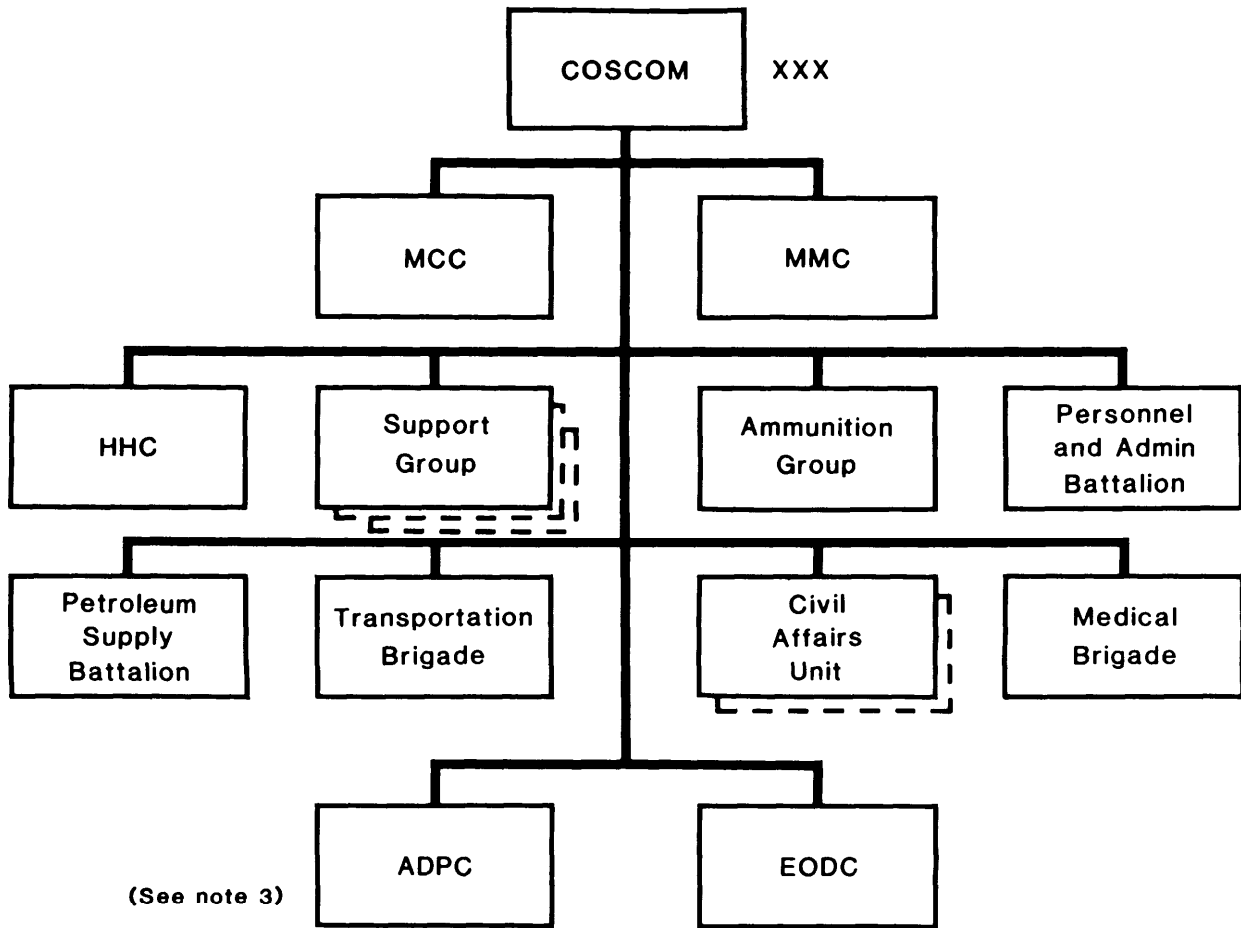

NOTES:

1. The command structure of the subordinate units is not rigid, i.e., groups will become brigades or brigades will be replaced by groups, depending on the magnitude of the mission requirement.
2. Company, battalion, or group-size organizations are assigned to the subordinate commands to tailor the support capability to meet the corps force requirements.
3. The application of automation to support CSS operations is changing from large data processing centers servicing several organizational elements to the assignment of dedicated ADPE to the using organization requiring the automation. Once this transition has occurred, the ADPC will be eliminated from the COSCOM structure.

Figure 2-3. COSCOM organization.

2 The division is the basic unit of the combined arms and services of the Army. It is the smallest unit in the Army in which all the arms and services are represented in sufficient strength to permit large-scale operations.

a The Division Support Command (DISCOM) usually deals directly with COSCOM units, the functional control centers, the corps finance support center and the explosive ordnance disposal control center.

b Within the armored and mechanized divisions, the major CSS units in the DISCOM are the main support battalion, forward support battalions and the aircraft maintenance company. (See Figure 2-4.) In the high technology motorized division, there are: a main support battalion, forward support battalions and a cavalry brigade air attack support battalion.

MECHANIZED DIVISION DISCOM

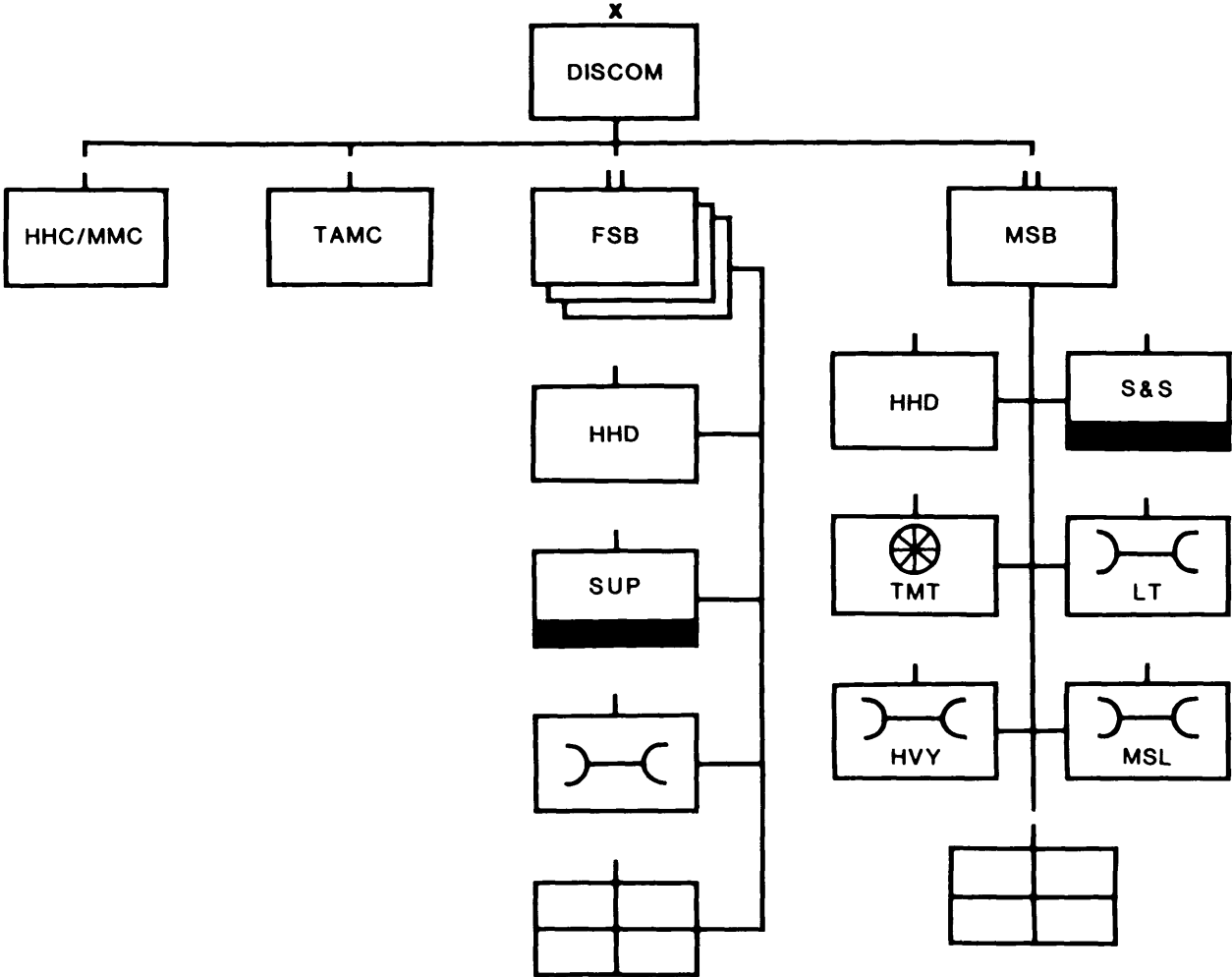

Figure 2-4. DISCOM organization.

c The airborne and light infantry DISCOM has medical, supply and transport, and intermediate maintenance battalions and an aircraft maintenance company.

d In the air assault division, the DISCOM is composed of medical, supply and transport, inter-

mediate (direct support), and aircraft maintenance battalions.

e The DISCOM provides DS to division units and their operations are coordinated by the division MMC. FM 63-2 provides detailed information on the DISCOM.

CHAPTER 3

DEPARTMENT OF DEFENSE GUIDANCE

Section I. INTRODUCTION

3-1. General

a. The basic objectives of the Department of Defense (DOD) are to be prepared to support national policies and to defend successfully the security of the Nation. To accomplish these objectives, the Secretary of Defense has been charged with establishing general policies and guidance for the military departments and the Defense Logistics Agency (DLA). These departments then develop their instructions for implementing the DOD instructions. The DOD policies and guidance are published in DOD directives, such as DOD Directive 3110.3, "Requisite Characteristics for Wartime Readiness of DOD Supply Systems," and instructions or other transmittals.

b. DOD has been charged with providing for a sustained state of industrial preparedness for production of essential military items identified and selected by the military departments. DOD is also charged with insuring the existence of adequate commercial maintenance/repair capability to meet readiness requirements for those items of materiel included in the approved forces but not supported by an organic depot maintenance capability.

(1) Basically, the military department and DLA are responsible for the selection of industrial preparedness planning items, the computation of emergency production requirements, and distribution of the requirements for items among industrial sources. This planning is limited to military end items or components which are essential to operational effectiveness under combat conditions, including training for the safety and survival of personnel. Because of the changing force levels and other information for determining requirements, the Secretary of Defense issues separate guidance annually for the computation of selected planning items.

(2) DOD planning policy provides for the application of controls on the economy to channel industrial effort from commercial to emergency support activities. It also considers measures to minimize leadtime and to maintain industrial base facilities in a high state of readiness and realistic

determination of total production requirement needed to support forces approved for mobilization. US Army forces mobilization planning and industrial preparedness are discussed in chapters 11 and 12.

c. Each DOD component is required to establish and maintain a positive and continuing war reserve program. It is DOD policy that DOD components select items for war reserve to initially sustain, in wartime, all necessary combat and combat support operations and the expanded logistics system required to maintain these operations. War reserve stocks are held and maintained to meet a War Reserve Materiel Requirement (WRMR). Stocks that are essential to the execution of initial wartime missions are prepositioned by the appropriate military service in accordance with international agreement and the Defense Guidance to insure timely support until replenishment can be effected. The military services have the responsibility for computation of Prepositioned War Reserve Materiel Requirements (PWRMR). Bulk petroleum Prepositioned War Reserve Materiel Stocks (PWRMS) are owned, financed, and managed by DLA. Management of petroleum products is governed by DOD Manual 4140.25-M, "Procedures for the Management of Petroleum Products."

d. The Secretary of Defense has assigned to the Joint Chiefs of Staff (JCS) certain responsibilities for the direction and control of the military services and those joint commands established by the President. These responsibilities are enumerated in DOD Directive 4100.1, "Functions of DOD and Its Major Components," and in JCS Pub 2, "Unified Action Armed Forces (UNAAF)." JCS provides guidance to the military services and the commanders of unified and specified commands for the development and execution of general war and contingency Plans. Basic logistics responsibilities for such planning are stated in JCS Pub 2, "Unified Action Armed Forces," JCS Pub 3, "Joint Logistics and Personnel and Policy Guidance," JCS Pub 15, "Mobility System Policies, Procedures, and

Considerations," and in volumes I and II of the "Joint Operations Planning System (JOPS)."

3-2. Military Standard Systems

The Military Standard Systems, e.g., Military Standard Requisitioning and Issue Procedures (MILSTRIP), Military Standard Transportation and Movement Procedures (MILSTAMP), etc., provide guidance for standardizing certain logistics operations and should be understood by the planner.

a. Military Standard Requisitioning and Issue Procedures (MILSTRIP). This is the conceptual base of all Military Standard Logistics Systems. It provides standard data elements, codes, forms, formats, rules, and procedures for requisitioning upon any military supply distribution system and for the issue of materiel required.

b. Uniform Materiel Movement and Issue Priority System (UMMIPS). The Uniform Materiel Movement and Issue Priority System is used in the requisitioning and issue of materiel from the DOD and the General Services Administration (GSA) distribution systems and in the movement of materiel in the defense transportation system. This system is used in peacetime and wartime and:

(1) Sets forth uniform requisition processing and materiel movement time standards.

(2) Provides a basis for managing the movement of materiel throughout the distribution systems.

(3) Insures the processing of materiel issue requirements in accordance with the mission of the requiring activity, the urgency of need, and specific materiel management considerations.

c. Military Standard Transaction Reporting and Accounting Procedures (MILSTRAP). These procedures uniformly classify inventory records as to ownership, purpose, and condition. They classify transactions affecting the inventory as to type of receipt, issue, and adjustment and provide the

basis for financial accounting of wholesale distribution system assets.

d. Military Standard Transportation and Movement Procedures (MILSTAMP). These procedures use the products of MILSTRIP and other systems to create and exchange standard shipping data in order to control materiel movements in the Defense Transportation System and to record and report their status. System administration is the responsibility assigned to the Secretary of the Army, Headquarters, Military Traffic Management Command (MTMC).

e. Military Supply and Transportation Evaluation Procedures (MILSTEP). Utilizing the issue and shipping documents of MILSTRIP and MILSTAMP, these procedures measure supply and transportation performance in terms of ontime shipments, and deliveries, stock availability, volume, and age of back orders.

f. Military Standard Contract Administration Procedures (MILSCAP). These procedures standardize the flow of purchase information among purchasing offices, contract administration offices, and inventory managers.

g. Military Standard Billing System (MILSBILLS). This system provides standard mechanized procedures and is used by DOD components for billing, collecting, and accounting for sales of materiel from supply system stock, including direct deliveries.

h. DOD Activity Address Directory System (DO-DAADS). This system provides identification codes, clear text addresses, and selected characteristics of organizational activities needed for materiel requisitioning, marking, shipping document preparation, billing, and similar applications.

i. Military Standard Petroleum System (MILSPETS). This system provides standard formats, data elements, and methods/procedures for inter-service/interagency use relative to the management of petroleum products.

Section II. JOINT LOGISTICS POLICY AND GUIDANCE

3-3. Logistics Responsibilities of the JCS

DOD guidance and appropriate joint service regulations/instructions and papers approved by JCS have been compiled and published in JCS Pub 3, volume II, Joint Logistics Policy and Guidance, for use by the military services and those joint, unified, and specified commands established by the President. The logistics responsibilities assigned to JCS of interest to the wholesale logistics planner were discussed in paragraph 2-5.

3-4. JCS Logistics Guidance for Commanders

JCS has developed several basic principles which provide guidance for commanders in their assignment of logistics responsibilities. Included are the following:

a. The assignment of logistics responsibilities should be such that the combat efficiency of the armed services as a whole is the most effective

which can be obtained within the limits of legislative authority and the availability of personnel, funds, and materiel. Prevention of unnecessary duplication or overlapping among the services, by utilization of the personnel, intelligence, facilities, equipment, supplies, and services increases military effectiveness and economy of resources.

b. Logistics systems should be designed for expansion to meet the peak loads they must bear in an emergency. In determining the means for meeting these loads, consideration should be given to full use of all existing facilities available within the Army, Navy, Air Force, Marine Corps, DOD agencies, other Federal agencies, and commercial sources.

c. Any assignment of functions or responsibilities must insure responsiveness to the operational and technical requirements of the commanders. The logistics organization directly supporting a given independent operation must be subject to the authority of the commander bearing the responsibility for operational success.

d. Any consolidation of facilities and/or services must not extend to the point where it deprives operational units of the support essential to their operational mobility and effectiveness.

e. Where joint use of facilities is directed, one service, normally the providing service, should exercise administrative control.

f. Where one service temporarily uses the personnel of another service, such personnel should function under the operational control of the service using them.

3-5. Emergency Wartime Readiness

JCS has also recommended certain characteristics for emergency wartime readiness. These recommendations have been approved by the Secretary of Defense for integration into the planning of all DOD supply systems. The departments and agencies of DOD are to integrate these characteristics into their plans for implementation of effective DOD supply systems, with DOD guidance and a realistic appraisal of the gravity of various emergency situations. Selective plans are developed for emergencies, general and limited war. These plans provide for liberalization of financial controls in emergencies and limited war and drastic reduction of controls in general war. Implementation is within the concept of balanced logistics readiness and approved logistics and financial objectives of approved departmental plans for emergency conditions. Within this guidance, all DOD supply systems must provide for:

a. Assumption of directive authority by commanders of unified/specified commands over facili-

ties and supplies of all assigned forces as necessary for the accomplishment of their mission under approved war plans.

b. Capability for timely and effective redistribution of assets employing all modes of transportation, including airlift, to meet emergency and wartime demands based on military operational priorities.

c. Direct, simple, and flexible procedures for requisitioning, purchasing, inspecting, issuing, financing, and accounting that will permit immediate emergency or wartime operation.

d. Access to a communication network which provides a means for timely interchange of information within the logistics system and between it and the activities supported.

e. Capability for implementing emergency or wartime production to permit prompt acquisition of essential items.

f. Adequate protection, security, and dispersion of supply, control and storage facilities, and materiel resources.

g. Capability for implementing and maintaining current approved logistics plans, in support of Joint and Service War Plans, which provide for expansion or adjustment of organization, personnel, and facilities to insure continuity of operations and accomplishment of assigned missions.

h. Organization to incorporate adequate supply management skill, technical competence, sensitivity to user demands, and liaison with other commands to provide effective support.

i. Capability for obtaining accurate and timely supply intelligence for planning, requirements computation, budgeting, acquisition, inventory management, storage and distribution.

j. Capability for rapid requirements determination and acquisition to meet emergency or wartime demands.

k. Maintenance of balanced ready-for-issue stocks located in dispersed distribution areas to insure rapid response to anticipated emergency or wartime demands.

l. Capability for rapid accumulation, analysis, and dissemination of systemwide inventory data.

m. Authority and capability to implement established priorities and allocations.

n. Access to airlift for direct delivery of supplies and equipment procured on an airlift pipeline basis as authorized by JCS.

o. The capability to award/administer and close out contracts.

Section III. MANAGEMENT OF WAR RESERVE STOCKS

3-6. Types of War Reserve Stocks

a. A primary element of military readiness is the sound and careful establishment and management of adequate war reserve stocks of essential military materiel. During an emergency or implementation of an operations plan, the materiel needs of military units must be met with existing stocks of equipment, supplies, and munitions until the supply line to the depot system in the Continental United States (CONUS) can be established. Equipment and supplies that are lost or consumed in combat, are replaced from prepositioned war reserve materiel stocks (PWRMS) sites located in strategically selected overseas areas. These pre-positioned materiel stocks greatly increase the capability to sustain frontline units.

b. Other CONUS stocks include the contingency support stocks, which support CONUS-based units that have worldwide contingency missions; stocks that enable the mobilization of the Early Mission Reserve Component units and the Full Mobilization Reserves; and residual stocks, known as Other War Reserve Materiel Stocks (OWRMS), which represent the balance of the projected combat loss replacement materiel that the military services and DLA are authorized to stock.

c. Special self-contained sets of Army materiel have been prepositioned in selected overseas areas and identified for specific companies and battalions. This prepositioning of materiel configured to unit sets (POMCUS) enables a unit to deploy rapidly by air without the bulk of its supplies and equipment and to fall in on prestocked materiel in certain geographic areas. The concept lightens the logistics burden of transporting the unit's equipment and, thus, greatly enhances strategic mobility. Much of the materiel authorized for POMCUS is located within humidity-controlled facilities, providing a long-term guarantee of serviceability. These assets are normally segregated from other war reserve stocks.

d. Another type of war reserve stocks is the operational project. These are items identified for specific plans or projects, and they are POMCUS and non-POMCUS. Items are restricted to those considered essential to success of the plan/project and initial requirements only. Other selected projects involve the expansion of area medical facilities, the repair of lines of communication after natural disasters, and the rehabilitation of airfield surfaces and facilities. The majority of the operational projects focus on the support of Europe; however, the CONUS and the Pacific region also receive significant attention.

e. War reserves management is categorized primarily into three functional areas. First, war reserves increase the sustainability of troops in the field by insuring that adequate materiel is available to replace combat consumption and losses until resupply from CONUS can be effected. Second, war reserves enhance strategic mobility by allowing deploying units to fall in on their equipment and supplies that have been prestocked in certain geographic areas according to the needs of the Army. Third, war reserves support contingency operations by providing selected stockage above and beyond authorized unit levels. The determination of the exact quantities required for each category and the location of war reserves is a challenging process that demands the compilation of data from diverse sources. For example, wear-out rates determine the amounts of clothing stored. Estimates of distance traveled and hours of use for different types of vehicles and equipment provide the data for petroleum requirements. Monthly failure rates provide a basis for estimates of heavy equipment and maintenance authorizations.

3-7. Establishment of War Reserves

The military services develop peacetime, sustaining (wartime), and intense (combat) usage factors for all major types of materiel. Stock levels are established for each class of supply and location in accordance with guidance from the Secretary of Defense and JCS.

a. Retail PWRMS are owned, financed, and managed by the services. If PWRMS is issued for support of urgent peacetime requirements, they must be promptly replenished to maintain the combat readiness capability of the PWRMS.

b. All items of other war reserve materiel stocks (OWRMS) are owned, financed, and managed by the DOD component assigned as inventory manager of the item. To meet peacetime requirements, these OWRMS may be issued under strictly controlled conditions. For secondary items, when issues against peacetime requirements are made from OWRMS the items must either be replaced immediately by the same items to maintain the required readiness condition or the funds conserved by the issue of OWRMS can be applied within the same budget category for other war reserve items to attain a more balanced OWRMS position.

c. The military services program procurement costs of stock-funded war reserves of service-managed items of PWRMS and OWRMS and DLA-

managed items held as service PWRMS. The services also program funds based on the DLA computation of each service's allocatable share of the total DLA OWRMS deficiency.

3-8. Selection of Items for War Reserves

a. It is not intended or practical to acquire and stock required quantities of all items. Only those items vital to the initial support of the operation need be selected for acquisition and stockage as war reserves. Funding limitations will constrain the acquisition of all items for war reserves. However, this should not prevent the selection of those items deemed essential for support. It is recognized that methodologies for selection of items based on service peculiarities will occur. Regardless of methodology the items must be justifiable in the defense budget. The criteria which govern the selection of items for war reserves are contained in DOD Directive 3005.5. The following criteria are to be used for war reserve item selection.

(1) items essential for combat forces to:

(*a*) Destroy the enemy or his capacity to continue war.

(*b*) Provide battlefield protection of personnel.

(*c*) Detect, locate, and maintain surveillance of the enemy.

(*d*) Communicate under war conditions.

(2) Items essential for the operational effectiveness of combat support forces and the expanded logistics system in support of combat forces.

(3) Items without which essential equipment or weapon systems would be inoperative or operationally ineffective.

(4) Items essential for the sudden mobilization and/or deployment of approved active and Reserve forces.

(5) Items required for survival and protection of personnel.

(6) Items designated as operational rations.

b. Special consideration must be given in the selection process to those items which:

(1) Are known to have production difficulties; e.g., long leadtime items; items where there is a

lack of adequate production capability, lack of required materials, or lack of specialized production skills or equipment; and items that require continuous surveillance of the production base.

(2) Have a single production source or which are predominately produced in a foreign nation(s).

(3) Are designed and fabricated only at military industrial activities and which are not available from commercial sources.

c. Items which do not meet the above criteria are prohibited from selection as war reserve. In general, these are items which are considered readily available from commercial sources, including subsistence (except operational rations); those under early development or procurement supported; those easily fabricated in the field; those which deteriorate or are unstable in storage; and those nonstandard, obsolete items being phased out of the system unless required to support materiel held by allies.

d. The provision of petroleum, oil, and lubricants (POL) in sufficient quantities and of proper quality is essential for modern military operations. The demands for such fuel can be expected to be high because of the employment of large numbers of Army aircraft and armored and other ground vehicles; the increased use of aviation for moving supplies and equipment, evacuating wounded personnel, and other logistics movement; as well as surface and subsurface marine vessels. Military requirements for bulk liquid fuels must compete with essential commercial requirements. Since the United States must depend on other countries to supply considerable amounts of POL to meet competing domestic and military requirements, and since commercial companies provide the bulk of transport and storage capabilities, a centralized system at the national level for obtaining adequate POL supplies and allocating them to the various users has been deemed necessary. Such control has been established at the national level in the Department of Energy and in DOD in the Defense Fuel Supply Center and its field offices in CONUS and overseas and the Joint Petroleum Offices in the unified commands. These organizations are responsible for emergency planning and contract administration.

CHAPTER 4

MILITARY PLANNING SYSTEMS

Section I. GENERAL

4-1. Introduction to Military Planning Systems

a. The purpose of this chapter is to discuss, in general terms, planning as a command function and to identify certain planning systems employed at various echelons of command. Planning is necessary to insure a disciplined approach to the protection of national interests and the achievement of national objectives. Planning molds available resources into an effective entity and is basic to other command functions. It must be emphasized that:

- (1) Planning is essential to the success of any military undertaking at all echelons of command.
- (2) Planning permits units to react rapidly to a variety of situations.
- (3) Planning is a responsibility of all members of the staff.
- (4) Planning processes vary with the echelon of command.

b. Procedures and techniques are generally the same, but the complexity, detail, and time elements differ with the level of command. Planning at division level is concerned more with the immediate future, while higher echelons project further into the future and cover a wider range of interest. At major command level, the area is restricted to that designated by higher headquarters. At Department of Army (DA) level, it is directed toward many types of possible Army commitments worldwide and extends many years into the future.

4-2. Characteristics of a Military Plan

a. A military plan defines a method or a scheme for a military action. It is a proposal to carry out a command decision or project. The military planning system:

- (1) Functions within the framework established by competent authority to provide input to the planning and decisionmaking process.
- (2) Is a component system of the resource management function which addresses the development of military strategy, policy, objectives, and

resource requirements in the execution of assigned roles and missions. The primary objectives of the planning system are to:

- (*a*) Provide timely and persuasive input to the planning and decisionmaking activities of the commander to obtain resource decisions which perfect his concepts.
- (*b*) Contribute persuasively to the formulation and presentation of strategy, objectives, and other matters of interest.

(*c*) Provide integrated and timely direction, guidance, and purpose to Army staffs and planners.

b. Planning bridges the gap between the present and the future by answering in advance who will accomplish what future actions, when, where, why, and how. Every commander has a planning function to perform. Effective planning is accomplished by the commander and his staff planners in the following manner:

- (1) Base plans on factors and relevant information. Computers may be used to assist in the compilation of manageable and pertinent data which are of use to a commander and his staff.
- (2) Use reflective thinking and imagination to foresee and perceive possible future actions. Planners must be able to state the problem and clearly visualize the pattern of activities which will occur during the execution of the plan. "What if" questions are answered by planning, enabling the commander or planner to consider many different variables that would affect the action to be taken.
- (3) Plan before acting. The planner should recognize the purpose of his actions and the usefulness of his achievement.
- (4) Plan continuously. All plans are tentative and subject to revision as new facts become known, resources change, and other variables become apparent.

(5) Divide plans into phases of time periods to help:

(a) Reduce the plan to a simple series of actions.

(b) Keep planned efforts on schedule.

(c) Coordinate the separate activities within the plan.

(d) Insure acceptance and awareness of the plan by all concerned or affected by it.

(6) Plans should:

(a) Be simple.

(b) Be easy to understand.

(c) Fulfill a recognized need.

(d) Be achievable.

(e) Be directed to the accomplishment of the objective.

(f) Be specific as to the responsibility, authority, and relationship of each group or individual involved in the plan.

(g) Be flexible. A plan should be capable of adjustment to meet unanticipated situations. Much creativity is required to develop such a plan, but it does reduce the requirement for last minute "crash basis" planning.

(7) Plan with tangible, definite, and specific factors. Planning deals with the activation of physical resources—men, materiel, money, and facilities.

(8) Plans consist of two components—variables and constants. The variables regulate the number of alternatives derived from a plan. As these reflect the experience and judgment of the planner, they represent the highest risk of the plan.

(9) Plans start with concepts and data which are manipulated, evaluated, refined, added to, subtracted from, integrated, portions changed, and revised until the final plan is formed.

4-3. Purpose of Military Plans

a. The planning system is designed to:

(1) Provide a threat analysis.

(2) Plan the effective utilization of forces and resources currently available and to task the appropriate Army commanders with the execution of the plan.

(3) Develop the forces to accomplish the objectives and the resource requirements to support the forces.

(4) Structure the approved forces and resources to execute the approved strategy and to achieve the military objectives.

b. Planning is one of the steps in making and executing decisions. This translates the commander's concept of operations into detailed procedures

for accomplishing the mission. The ability to translate these decisions and concepts into easily and clearly understood instructions for subordinates is an art and one of the most important functions of a military staff.

4-4. Sources of Missions

a. Missions are derived in most instances from instructions or directives from higher headquarters. However, a commander need not wait for instructions from higher headquarters to initiate planning. Frequently, planning is initiated by a commander based on his knowledge of the situation and assumed mission(s). It would appear to be only natural at division level and higher in a theater of operations to assume that many situations could arise which would require immediate reaction. Thus, planning may be initiated by a commander based upon his knowledge of the existing situation, some assumptions, and consideration of all situations with which he may be confronted.

b. The unified commander is assigned missions and tasks and provided resources with which to carry them out through the Joint Strategic Planning System (JSPS). Planning at the unified/specified command and military service level is initiated by the Joint Strategic Capabilities Plan (JSCP) within the JSPS. The JSCP assigns tasks; provides planning guidance for development of operations plans to accomplish those tasks; identifies major forces available; and provides guidance for development of plans to accomplish tasks. In addition, the mission or tasks may be assigned by a letter of instruction (LOI), a planning directive, or derived or assumed by the commander based on general guidance from higher headquarters and his own initiative.

c. The commander of unified/specified commands, chiefs of military services, and commanders of joint task forces (JTF) or major operational commands may assign missions and tasks and transmit their directions and guidance through the use of any of the following:

(1) Service planning documents such as the Army Mobilization and Operations Planning System (AMOPS).

(2) A campaign plan which is fundamentally a strategic document. These have been used by major area commanders to sketch broad outlines of a series of strategically connected operations. Joint Chiefs of Staff (JCS) Publication 2 provides a format for a campaign plan.

(3) An LOI has historically been used by commanders at high levels to convey planning guidance. It is a flexible document that can be used in

many situations, in any size operations, and for many purposes. If the LOI is used, it should contain as much of the information prescribed (in the format in JCS Publication 2) for the campaign as required for the situation addressed.

(4) A planning directive is used by many joint staffs to set forth the commander's guidance early in the planning process. It provides written guidance to the commander's staff, subordinate and supporting commands, and agencies to aid in concurrent planning.

(5) An outline plan is a preliminary plan outlining the salient features or principles of a course of action prior to the initiation of detailed planning.

(a) The purpose of the outline plan is usually one of the following:

1 To convey the unified or joint level concept of operation, allocation of major combat forces, planning direction and guidance, planning tasks, and concept of logistics support to all subordinate and supporting commands for their use in plan development.

2 To provide higher staffs with an appreciation of what direction the commander's planning is taking and, if appropriate, to substantiate requests for allocation of additional troops or other resources.

(b) Outline plans, when used, are usually early versions of the operation plan (OPLAN) or operation order (OPORD) developed by the staff after an overall concept of operations has been formed.

(c) There is no prescribed format for an outline plan. Within the limits imposed by the amount of planning work accomplished, the outline plan should include as much of the information that will be contained in the final plan as possible. Annexes should be employed but are not mandatory if the purpose of the outline plan can be accomplished without them.

(6) A JCS Warning Order is issued by the JCS in the Crisis Action System (CAS) to initiate course of action development (CAS Phase III). The following information will be included to the extent possible.

- (a) Command arrangements.
- (b) Task(s).
- (c) Area of operations.
- (d) Situation.
- (e) Forces.
- (f) Assumptions.

(g) Political factors.

(h) Tentative courses of actions (for CINC consideration).

(i) Operations.

(j) Administration and Logistics.

(k) Reporting Instructions.

(7) An Alert Order is a directive prepared and issued by the JCS, which conveys the National Command Authority (NCA) decision to prepare for military operations in support of national interests. When issued by the JCS to the supported commander and other participants, the Alert Order marks the beginning of execution planning (CAS, Phase V). It does not authorize or direct the implementation of the plan, but certain forces can begin movement if specifically authorized. As a minimum, the Alert Order will include:

(a) A description of the politico-military situation.

(b) The tasks to be accomplished.

(c) The allocation of major combat forces and strategic transport resources to the operation.

(d) The movement priority assigned to the operation.

(e) The target date for execution.

(8) An Execute Order is the implementing directive issued by the JCS when the NCA decides to employ US military forces. The Execution Order goes to the supported commanders, the transportation operation agencies (TOA), and the services. The Execution Order designates the date of C-day (day deployment commences), and may contain the date designated as D-day. If controls or parameters by which subordinates will conduct operations are required, they will also be contained in the Execute Order.

4-5. Plan Development

a. In developing a plan, a series of steps which lead through a logical progression of command and staff action is generally followed.

(1) The first step is forecasting probable commitments. Here the commander and his staff analyze and evaluate trends to predict future developments-or higher headquarters may initiate the planning sequence. Since all the facts are not known, it is necessary to make certain assumptions which are general in nature and are relevant. The higher the echelon of command, the greater the necessity for longer range planning and the greater the number of assumptions. The probability that events will not occur as assumed

will also increase, thus the inherent likelihood of change.

(2) The second step involves the analysis of probable commitments, what the commander thinks will occur, and assignment of priorities of these possible occurrences. Planning is initiated on the situation with the highest priority and proceeds through others until all are exhausted or are overtaken by events. These also change constantly as events occur and are acted upon.

(3) The third step is determining the mission. If none is assigned or apparent, the planner must try to anticipate what the mission should be. This could result in assumption of more than one probable mission. If more than one mission is assumed, priorities must be established to continue planning.

(4) Next, the mission is analyzed to determine specific and implied tasks, their complexity, and relative importance. Frequently, planners will identify those elements or tasks that require immediate and/or obvious reaction but fail to recognize the less obvious or those with long-range or recurring implications.

(5) After determining what must be accomplished and the relative importance of each task, it is necessary to determine how to keep all planners moving in the proper direction. This involves the use of existing policies and procedures plus guidance from the commander or higher headquarters.

(6) Studies may be initiated to determine the feasibility and influencing factors for accomplishing the assumed missions. Staff estimates and staff studies are used more frequently at the echelons below DA. At DA and major command level and higher echelons, concept studies are used for long-range planning in addition to staff studies. These planning studies narrow the problems to those situations which can reasonably be expected to occur. It eliminates those situations which cannot or are least likely to occur. From those remaining possibilities are selected all reasonable courses of action and theoretically a plan is prepared for each although the objective of the process is to identify the best one.

(7) After the plan is complete, and whenever possible, the proposed operations should be rehearsed. Until a plan is implemented, it must be constantly reviewed, refined, and updated.

b. The planning sequence must be modified somewhat for a commander's decision where he has been assigned a mission by higher headquarters. In this instance, the mission is received, disseminated to the staff, analyzed, planning guidance furnished, staff estimates made, commander's

estimate and concept of operation stated, and OPLANs prepared, approved, and issued for implementation. The commander and his staff must then supervise the implementation of the order.

4-6. Organization for Planning

a. The organization for planning varies with the command level, complexity, and time frame involved. There are several alternatives as to how to organize to conduct planning. It can be accomplished by existing staff, a permanent planning group, a temporary group, or a combination of the above. For normal planning operations, the existing staff is used. It is capable of planning for operations which do not impose any highly unusual conditions. However, if the operation requires extensive staff planning and supervision, is highly sensitive in nature, is complex and timeliness of action is significant, creation of a separate planning group would be warranted. With this special-group, the staff sections of the headquarters could concentrate on their daily operational requirements. At the same time, the commander could bring together in one section personnel possessing required expertise from his headquarters and subordinate commands to accomplish the planning.

b. The important aspect of planning in any organization is that the responsibility is specifically assigned, understood, and the various planning actions can be traced within the organization. The responsibility for planning must not be so fragmented within the command that it is uncoordinated and lacks integration with other plans.

4-7. Types of Plans

The military planner should be cognizant of the type plans he may be working with. The significant plans which the planner should recognize are:

a. Strategic Plan. This type plan provides for the overall conduct of a war. By its description, it is obvious that these plans are formulated at theater and higher headquarters. The National Security Council (NSC) is the principal forum for consideration of national security policy issues, requiring Presidential decision. The Department of Defense (DOD), in coordination with other executive departments, translates those decisions and national strategy objectives into national military strategy with strategic military objectives. JCS uses these objectives and considers the recommendations of theater commanders and the total military capabilities of the nations to arrive at a war plan that will accomplish the objectives. From these come assignments of missions to theater commanders upon which to base specifications for operations.

b. Campaign Plan. This type plan covers a series of related military operations to accomplish a common objective, normally within a given time and space. Such plans are normally prepared by joint or combined commands. Several campaigns may be undergoing planning concurrently, each including operations or undertakings of considerable magnitude. The plan may be prepared to meet a probable or an existing situation. (See also paragraph 4-4c(2).)

c. OPLAN. This is the most basic of staff directives.

(1) This is a plan for a military operation (normally part of a military campaign). It covers a single operation or a series of connected operations to be carried out simultaneously or in succession. It is usually based upon stated assumptions and is the form of directive employed by higher authority to permit subordinate commanders to prepare supporting plans and orders. The OPLAN is usually used instead of an order in preparing for operations or contingencies well in advance. An OPLAN may be put into effect at a prescribed time, or on signal, and then must be translated into an OPORD. It is an essential link between the commander's decision and the initiation of action.

(2) In the context of Joint Operations Planning System (JOPS), an OPLAN is prepared in either complete or concept format.

(a) OPLAN in Complete Format. An OPLAN for the conduct of military operations can be translated into an OPORD with minimum alteration. Complete plans include deployment/employment phases, as appropriate. A complete plan normally is prepared for those situations wherein plan execution would:

1 Tax total forces available for planning.

2 Tax the available logistics or mobility resources under either mobilization or nonmobilization conditions.

3 Be likely to occur within the JSCP time frame.

(b) Operation Plan in Concept Format (CONPLAN). This is an OPLAN in an abbreviated format, reflecting the commander's concept of operations. It requires expansion into an OPLAN or OPORD prior to implementation.

(3) Administrative instructions and formats for the documentation and distribution of OPLANs and annexes are contained in JOPS, volume I, chapters IV, V, and VI.

4-8. Special-Purpose Plans

There are a number of terms used to describe special types of military plans written for the pur-

pose of prescribing actions to be taken in response to specified or anticipated future events. Such plans include a variety of administrative and support plans, base development plans (BDP), contingency plans, and emergency defense plans.

a. Administrative Plan. Administrative plans for several of the functional areas of administration and support frequently have a broad range of application in both peace and war. Sometimes called "omnibus plans," administrative plans may be designed to provide for the combat service support (CSS) of a type force unit or for the maintenance of a specified supply level at a forward port or any number of other administrative or support actions. It is based on the commands' operational requirements. When implemented, it is the administrative order.

(1) Like an annex to an OPLAN, an administrative plan may be attached to an OPLAN or referenced as a supporting document. When referenced, the originator of the OPLAN must ascertain that all required recipients of the OPLAN do, in fact, hold the appropriate administrative plan.

(2) Administrative plans are frequently employed by service component commanders, but are less commonly used by joint commanders.

(3) There is no universally prescribed format; however, FM 101-5 contains Army-unique formatting instructions.

b. Base Development Plan. Base development is the improvement or expansion of the resources and facilities of an area or a location to support military operations. It can be conducted for the purpose of improving or expanding facilities for the long term or may be conducted in light of a prevailing contingency requirement.

(1) When military operations are projected into an area where no existing base facilities are available, or where those facilities need improvement and organization to support military operations, base development is a necessary activity. Such plans can be drawn for development of a specific base, such as a port or air terminal; or, like the other support plans already discussed, they can be written to cover a broader area and wider time period. In joint planning, base development is a part of the plan development phase and is described in paragraph 5-13.

(2) As described in JOPS, volume I, aspects of base development requirements are incorporated into the logistics annex of an OPLAN.

(3) Base development data, submitted in accordance with JCS Publication 6, volume II, is required by the JCS for all OPLANs

c. Contingency Plans. A contingency plan is a plan for contingencies which can reasonably be anticipated in an area of responsibility. The form that a contingency plan takes is determined by the nature of the situation, the magnitude of the force and resource requirement, and the complexity of the strategic mobility problem involved. OPLANs, emergency defense plans, evacuation plans, or any other plans developed for use in contingency situations are frequently referred to as contingency plans.

d. Emergency Defense Plan. This is a common term used mostly in the European Command and in the North Atlantic Treaty Organization (NATO) arena. An emergency defense plan is a contingency plan designed to accelerate actions to meet a defense emergency situation with resources at hand. There is no prescribed format for an emergency defense plan. It is usually in a form similar to that of an OPORD.

e. Alternate Plan. Generally, an alternate plan provides for a different course of action to be taken in the event assumptions or significant facts, under which the original plan was written, prove no longer to be true. Alternate plans are documented in the format of the basic plan for which they serve as an alternate.

f. Evacuation Plan. Evacuation plans are developed for a variety of contingency situations in which the movement of people (both military and civilian) for security, safety, or medical reasons or the movement of materiel for maintenance or disposal reasons is required. There is no prescribed format for an evacuation plan.

g. Supporting Plan. This type plan complements another plan and is usually added as an annex to the basic plan. Examples which are of particular importance to logistics are traffic circulation and communications. A BDP also may be a major supporting plan.

h. Emergency Plan. This plan deals with disaster relief and other similar events.

i. Mobilization Plan. Describes the action to activate units and installations to meet national requirements.

4-9. Combat Orders

Combat orders pertain to strategic or tactical operations and attendant CSS in the field. They may be issued initially as a plan to become an order at some future time. These orders are classified as:

a. A Directive. This is an oral or written military communication establishing a policy or ordering a specific action.

b. A Letter of Instruction. This is a form of order by which higher commanders give information re-

lating to broad aims, policies, and strategic plans for operations in large geographic areas over long periods of time.

c. An Operations Order OPORD. This is a directive issued by a commander to subordinate commanders for the purpose of effecting the coordinated execution of an operation. The operations officer (G-3) has responsibility for preparing the order. The OPORD almost invariably deals with a specific, scheduled tactical operation in the near future, involving the actual movement of forces. It is limited, both in time and in area covered. The format for the documentation of an OPORD is prescribed in JCS Publication 2, JOPS volume I, and FM 101-5.

d. Fragmentary Order (FRA GORD). This is usually issued on a day-to-day basis eliminating the need for restating information contained in the OPORD. As its name implies, a FRAGORD is a fragment or part of an OPORD. It is an action directive, usually used to convey operating schedules, target lists, and a variety of other elements of an OPORD. Typically, FRAGORDs are used to effect the movement of a group of ships or aircraft in the desired direction before detailed plans for their employment upon arrival have been prepared. The FRAGORD is a purely tactical device. No format is prescribed, but good practice would dictate that its elements be stated in the sequence prescribed for OPORDs.

e. Warning Order. A Warning Order is a preliminary notice of an order or action which is to follow. It is designated to give subordinates time to make necessary plans and preparations. Although it is not an action directive, it is frequently used as a prelude to an Alert Order, OPORD, or FRAGORD and may indicate a need to adjust the defense posture in a specified area. While there is no prescribed format for the documentation of a Warning Order, most commands employ a system of emergency action procedures which contain useful Warning Order formats.

4-10. Standing Orders and Procedures

a. Standing Orders. Frequently a unified or other high-level command will prescribe its overall organization, mission, general scope of routine operations, and other standard procedures and practices for a specified period of time, such as a fiscal or calendar year, in standing orders. Such documents do not describe a specific operation, other than the normal training and security operations, but do provide a basis on which subordinate commanders can conduct current operations. OPLANs and OPORDs for specific operations in commands

using this technique are then written to describe the specific operation, referring to overall ongoing orders for such details as communications, logistics support, and organization.

b. Standing Operating Procedures (SOP). Another technique for providing the ongoing direction required for current operations is the use of SOPs. These are a set of instructions covering those features of operations which lend themselves to a definite or standardized procedure without loss of effectiveness. The procedure is applicable unless otherwise prescribed in a particular case, allowing flexibility in special situations to be retained. SOPs are usually made effective for a specified period of time, and reference is made to them in plans and orders published for specific operations during that time. They may be used to prescribe standard procedures for communications, operations, and other matters, as well as support activities such as logistics and personnel matters.

c. Standing Logistical Instructions (SLI). Several major Army commands (MACOM) have issued standing procedures which define responsibilities and prescribe logistical instructions, policies, and procedures to be followed in planning and executing contingency plans.

4-11. Annexes to OPLANs and OPORDs

a. General. Annexes to OPLANs and OPORDs contain those amplifying instructions which, due to their volume or technical content, are undesirable for inclusion in the main body of the document.

b. Types of Annexes. Much of the usefulness of an OPLAN or OPORD depends on the care and imagination used in the preparation of its annexes. There will always be material which, logically, could be included either in the body of the plan or in the annexes. Both judgment and experience must be used to determine what materiel should be included in the body of the plan in order to make it a coherent whole, without going so far that it is overly cluttered with detail.

c. Format. JOPS volumes I and II contain administrative instructions, sample formats, and guidance relative to content for each of the required annexes. In the event a special-purpose annex is needed for which there is no prescribed format, the local practice of the command involved should be followed.

d. Separately Issued Annexes or Plans.

(1) When required for security reasons, or when necessary to facilitate distribution, separately issued annexes or accompanying plans may be employed.

(2) When annexes or accompanying plans are separately issued, care must be taken that they are clearly marked in accordance with JOPS, volume I, formats to avoid confusion with other supporting plans, annexes, or orders.

(3) In some cases where separately issued annexes or plans are employed, it may be desirable to include a summary of the OPLAN or OPORD at the beginning of the document for completeness and clarity.

Section II. NATIONAL MILITARY PLANNING

4-12. National Level Planning System

a. National Security Council (NSC) System. National military decisions are the responsibility of the President. The NSC is the principal forum for Presidential consideration of foreign policy issues and national security matters. The NSC system is designed to make certain that clear policy choices reach the top. The decision (i.e., the determination of the best course of action) is clearly that of the President. Presidential decisions are promulgated in the form of National Security Decision Memoranda (NSDM). The President of the United States as the President of the NSC is ultimately responsible for decisions concerning national security. The manner in which the President uses the NSC is at his discretion. The relative weight given views of the various members of the council will naturally be determined by the President, and should be influenced by the nature of the consideration in

question. The main purpose, however, is to insure that the views and possible bias of one department do not dominate policy choices presented to the President for decision.

b. The Joint Strategic Planning System (JSPS). The Joint Chiefs of Staff are charged by the National Security Act of 1947 with preparing strategic plans and providing for the strategic direction of the Armed Forces. The JSPS, as prescribed by JCS Memorandum of Policy 84 (MOP 84), provides the framework for strategic and force planning. Joint strategic planning begins the process which creates the forces whose capabilities form the basis for theater operation plans. The JSPS constitutes a continuing process, in which each document or program is an outgrowth of preceding cycles and of documents formulated earlier, and in which development proceeds concurrently. A discussion of the JSPS documents follows:

(1) *Intelligence Priorities for Strategic Planning (IPSP)*. The IPSP provides a comprehensive statement of substantive military intelligence priorities to support the tasking of DOD intelligence production, collection, and support activities in the short-range and mid-range periods.

(2) *The Joint Intelligence Estimate for Planning (JIEP)*. The JIEP contains detailed estimative intelligence for the short-range and mid-range periods. It concentrates on possible worldwide situations and developments that could affect US security interests in the short-range and mid-range periods. A JIEP Supplement contains significant changes in intelligence occurring between annual publications of the JIEP, military capabilities and vulnerabilities of Armed Forces of selected countries, and force tables for selected countries. The JIEP provides the principal intelligence basis for the development of the Joint Strategic Planning Document (JSPD), the Joint Program Assessment Memorandum (JPAM), and the Joint Strategic Capabilities Plan (JSCP).

(3) *The Joint Long-Range Strategic Appraisal (JLRSA)*. This document serves as the basis for transition from mid-range to long-range strategic planning. It focuses on strategic studies and analysis and influences the mid range JSPD. The document also provides a framework for development of a baseline to assess military policies, plans, and programs having mid-range and long-range implications. The JLRSA postulates four possible future world environments and presents trends and developments for selected regions. Significant military threats to the interests of the United States are stipulated, and strategy to meet those threats is presented. The JLRSA is reviewed biennially and revised every four years.

(4) *The Joint Strategic Planning Document (JSPD)*. The JSPD provides the advice of the Joint Chiefs of Staff to the President and the Secretary of Defense and to the National Security Council on the military strategy and force structure required to support national security objectives. It establishes the position of the Joint Chiefs of Staff on matters of strategic importance, and it influences the development of the Defense Guidance (DG). The JSPD includes a summary of force levels that would be required to execute the national military strategy with a reasonable assurance of success. JCS also provide their views on the attainability of these forces.

(5) *The Joint Strategic Capabilities Plan (JSCP)*.

(a) The JSCP issues guidance to the commanders of unified and specified commands and the chiefs of the services for accomplishment of

military tasks in the short range period. This tasking is based on the capabilities of available forces, intelligence reports, and guidance issued by the Secretary of Defense. It directs the development of plans to support national security objectives by assigning tasks to the commanders of unified and specified commands.

(b) The JSCP is prepared in two volumes: volume I, Concept, Tasks, and Planning Guidance; and volume II, Forces.

1 Volume I of the JSCP provides strategic military concepts for each of the major regions corresponding to the unified command areas. It also includes assignments of tasks to the commanders of unified and specified commands and planning guidance to the services for the support of the unified and specified commands in the execution of assigned tasks.

2 Volume II identifies the major combat forces available to the commanders of unified and specified commands for the development of OPLANs, and cites the applicable service documents to aid in determining, for planning purposes, the availability of forces not specifically shown in volume II.

3 There are 14 annexes to the JSCP that contain additional planning guidance, indicate capabilities, and amplify Volume I taskings. Annex B (Logistics) is of particular importance to the logistics planner. It contains logistics planning guidance to the unified and specified commands, the services, Defense Logistics Agencies; a statement of the services support capabilities; logistics factor file; and apportioned CINC identified critical items.

(c) The JSCP is published annually and revised between cycles as necessary.

(6) *Joint Program Assessment Memorandum (JPAM)*. The JPAM provides the views of the Joint Chiefs of Staff on the adequacy and capabilities of the total forces contained in the Service Program Objective Memorandums (POM). It is not intended to be a critique of the individual military department POMs. Rather, it is an assessment of the capabilities generated by the composite POMs. to execute the national military strategy and an estimate of the risks inherent in those force capabilities. Commanders of unified and specified commands are invited to comment on the composite POMs as they relate to current strategy.

(7) *The Joint Security Assistance Memorandum (JSAM)*. The JSAM provides military views on the Security Assistance Program. It is based on an analysis of US military interests, security assist-

ance objectives, and desired force levels for allied and friendly nations.

c. DOD Planning, Programing, and Budgeting System (PPBS).

(1) The Secretary of Defense is the principal assistant to the President in all matters relating to the DOD. Translating national security policy into plans, programs, organizational assignments, and implementing guidance, the Secretary of Defense ascertains and considers the views of appropriate officials of the Office of the Secretary of Defense (OSD), the military departments, the JCS, and other DOD agencies.

(2) Decisions pertaining to planning, programing, and budgeting are made by the Secretary of Defense under the authority granted in the Defense Reorganization Act of 1958. This legislation gave the Secretary of Defense, under the policy guidance and direction of the President, two distinct lines of authority. A direct line of command, commonly referred to as the joint or unified chain, was established through the JCS to the commanders of the unified and specified commands. Through this command line of authority, the Secretary of Defense issues decisions regarding threat appraisal, strategy, and force structure. A second line of authority, known as the departmental line, extends from the Secretary of Defense through the secretaries of the military departments. Through this chain the Secretary of Defense issues decisions regarding programing of resources to support the force structure and budgeting of funds to support programs.

(3) Basically, the PPBS can be summarized as follows:

(a) Strategy is developed in consideration of the threat.

(b) Force requirements are developed to support the strategy.

(c) Programs are developed to provide an orderly basis for the achievement of force objectives, weapons systems objectives, and their logistics support.

(d) Budgets are formulated to support requirements within the resources that the nation provides.

(e) The PPBS results in the President's budget which goes to Congress and is reflected in the DOD Five-Year Defense Program (FYDP).

d. Joint Operation Planning System (JOPS).

(1) The JOPS was established by the JCS and directed for use in joint planning. JOPS formalizes and standardizes administrative procedures, data exchange and storage, and plan format. It provides

the framework for all joint planning in which the deployment of forces is the prime concern. It is oriented toward the solution of complex strategic mobility problems associated with force deployment and support. JOPS also provides for increased use of automation and computer application in all phases of joint planning.

(2) JOPS is the planning system which establishes uniform policies and procedures to be used in the planning and support of joint military operations. Its objectives are to:

(a) Minimize the number of OPLANS which must be prepared in complete detail.

(b) Facilitate the preparation, use, and understanding of OPLANS which must be prepared in complete detail.

(c) Facilitate the preparation, use, and understanding of OPLANS by standardizing formats and minimum content.

(d) Incorporate all practicable automatic data processing (ADP) techniques in support of operation planning.

(e) Provide for effective review of OPLANS, continuity of OPLANS, emergency evacuation plans, and disaster relief plans submitted to fulfill planning tasks assigned or approved by the JCS.

(f) Establish procedures for the reporting and processing of resource shortfalls and limiting factors identified during the planning process.

(3) JOPS derived from the need for a planning system which is universally understood and which facilitates data exchange; rapid reaction; judicious employment of limited resources; early identification and processing of shortfalls; and valid testing, review, and supervision of military OPLANS. Unified and specified commanders employ the guidance and procedures prescribed in JOPS in their preparation of new plans and in major revision of existing plans. Accordingly, the principles of JOPS have been incorporated into staff and command instructions of the unified and specified commands and, in certain instances, the staff and command instructions of the services and service component commanders. Though specific staff division responsibility for the development of elements of a plan may differ among the various staffs, the procedures inherent in JOPS are employed in all joint planning. JOPS is discussed in more detail in chapter 5.

(4) JOPS is published in four volumes:

(a) JOPS Volume I, *Deliberate Planning Procedures*, is unclassified. It gives guidance and administrative procedures for the development, co-

ordination, dissemination, review, and approval of joint operation plans. In addition, Volume I prescribes standard formats and minimum content of operation plans, annexes, and appendices.

(b) JOPS Volume II, *Supplementary Planning Guidance*, is classified. It is functionally oriented and lists certain directions, procedures, and planning guidance which are keyed to certain plan annexes.

(c) JOPS Volume III, *ADP Support*, is unclassified. It describes the Worldwide Military

Command and Control System (WWMCCS) standard automated planning system and contains a description of the standard reference files and JOPS ADP application programs that assist the planner.

(d) JOPS Volume IV, *Crisis Action System—(CAS)*, is unclassified. It sets forth guidance and procedures for joint planning during emergency or time-sensitive situations. The procedures allow the JCS to make timely recommendations to the National Command Authorities (NCA) for decisions involving the use of US military forces.

Section III. GUIDANCE DOCUMENTS AND THE JOINT REPORTING STRUCTURE

4-13. Introduction

a. The military planner requires access to enormous amounts of information in developing plans for military operations. Probably one of the planner's most valuable assets is a library of relevant guidance and doctrinal publications. JOPS, volume II, contains a table of references which identifies many documents, both classified and unclassified, that are employed by military planners.

b. It is not the purpose of this manual to discuss all of the documents required by a planner. However, certain documents have been selected for brief discussion because of their wide application to planning for military operations at the unified/specified command, military service and higher command levels. Military planners should have an understanding of the selected joint documents and applicable service-unique documents.

4-14. Guidance Documents

a. *JCS Publication 1—Dictionary of Military and Associated Terms*. The DOD Dictionary contains a listing of commonly used military terms along with agreed definitions. The standardization of military terminology has become increasingly significant as a major step toward effective communication and common understanding within the DOD, between the United States and its allies, and within the civilian-military community. Better communications and understanding are achieved by the consistent use of an agreed definition for a given term and by avoiding the use of different terms with the same meaning.

b. *JCS Publication 2—Unified Action Armed Forces (UNAAF)*. A thorough understanding of UNAAF is a basic requirement for all staff officers. It sets forth the principles, doctrines, and functions governing the activities and performance of the Armed Forces of the United States when two or more services are acting together. It pro-

vides military guidance governing both exercise of command by unified, specified, JTF, and other joint force commanders and doctrine for unified operations and training. It also provides military guidance for use by the military departments and the Armed Forces as needed in the preparation of their respective plans,

c. *JCS Publication 3—Joint Logistics Policy and Guidance*. JCS Publication 3 is a compilation of logistics guidance extracted from DOD directives, joint service regulations, and JCS papers. It describes the logistic responsibilities of the JCS and the commanders of unified and specified commands and states the policies and principles governing interservice and interdepartmental logistic support. It addresses supply, deployment, civil engineering support, transportation, and it highlights the requirement for the conduct of logistic planning concurrently with operation planning.

d. *JCS Publication 4—Organization and Functions of the JCS*. JCS Publication 4 consists of approved organizational documents and serves as a valuable ready reference and orientation document for staff officers. It contains organization charts for and a description of the functions of the joint staff and of most of the commands and agencies that report through or to the JCS. Though this document may not be cited as an official source document, it will lead the user to official source documents which can be cited.

e. *JCS Publication 15—Mobility System Policies, Procedures and Considerations*. JCS Publication 15 contains an accumulation of policies, procedures, and data for use in mobility system planning. Though it is not directive in nature, it is designed for the use of operational and support commands in the determination of gross movement requirements with acceptable accuracy. JCS Publication 15 provides guidance relative to the responsibilities and relationship of the principal agencies in-

volved in mobility planning and lists source reference documents that can be cited when needed. Additionally, JCS Publication 15 provides airlift, sealift, land transportation, and mobility support facility planning factors that are used in the development of gross requirements.

f. Unified Command Plan (UCP). The UCP is the basic document which establishes the unified and specified commands. It is approved by the President, published by the JCS, and addressed to the commanders of unified and specified commands. The UCP delineates areas of responsibility, assigns primary tasks, defines authority of the commanders, establishes command relationships, and provides guidance on the exercise of operational command.

g. Documents which describe the Army-unique planning systems are:

(1) FM 101-5, Staff Organization and Procedures and FM 101-10-1, Staff Officers' Field Manual, Organizational, Technical and Logistics Data (Unclassified).

(2) The principal Army planning document with specific application in the development of OPLANs that supports the JSCP is the AMOPS.

(3) Army component commanders employ the direction and guidance provided in both the unified chain of command and the service chain of command in developing their supporting plans.

4-15. Joint Reporting Structure (JRS)

a. The JRS, established by a decision of the JCS and directed for use throughout the military community, is designed to:

(1) Provide, to the maximum extent possible, the military information required for the NCA to perform their functions.

(2) Provide a centrally coordinated catalog of recurring joint and individual service and DOD agency reporting requirements necessary to support command decisions in planning, execution, and postoperational analysis of military operations.

(3) Preclude the generation of duplicative recurring reporting requirements.

(4) Advance the standardization of the joint, service, and DOD agency reporting systems within the JRS.

b. The JRS makes provisions for reports and reporting systems that have wide application in command and control, support planning, operation planning, and plan execution and analysis. It portrays essential data relative to: personnel, materiel, and equipment status; operational and logistics planning; and the overall military situation. It establishes:

(1) Procedures for the preparation of reports.

(2) The framework for reporting systems through which data are transferred between participating commands, as appropriate.

(3) The Standards for Automatic Data Processing (ADP) within the structure.

c. While a specific element, report, or reporting system within the JRS may be more closely associated with one functional area within a given staff organization than another, a basic familiarity with the JRS in its entirety is a requirement for all staff officers. JCS Publication 6 indicates the specific elements, reports, and reporting systems within the JRS.

d. The JRS is published in six volumes:

(1) Volume I contains general instructions and defines reporting responsibilities.

(2) Volume II contains a description of joint reports and reporting systems, provides administrative instructions and formats for data documentation, and defines the data elements. It is divided into 14 parts:

(a) Part 1: Standard Operating Procedures for the Coordination of Atomic Operations (CAO SOP).

(b) Part 2: Unit Status (UNITREP).

(c) Part 3: (Deleted).

(d) Part 4: Nuclear Weapon Reports (NUREP).

(e) Part 5: (Deleted).

(f) Part 6: Reconnaissance.

(g) Part 7: Communications Status.

(h) Part 8: Communications Electronics.

(i) Part 9: Military Installation Status.

(j) Part 10: Intelligence.

(k) Part 11: Joint Operation Planning System.

(l) Part 12: Personnel.

(m) Part 13: Logistics.

(n) Part 14: General Use/Miscellaneous.

(3) Volumes III, IV, V, and VI catalog the unique service reports and reporting systems of the Army, Navy, Air Force, and Marines, in that order. Each report is described in terms of subject and purpose, originating agency, receiving agency, frequency, method of transmission, and specific data elements.

e. All elements of the JRS have specific application in situation monitoring, joint planning, and

joint operations. Some of the reports and reporting systems included in JCS Publication 6, volume II, have been selected to illustrate the depth and coverage of these reports and reporting systems.

(1) *Defense Intelligence Notice (DIN)*. The purpose of the DIN is to provide the JCS, the unified and specified commands, the services, and selected agencies with timely intelligence regarding events that could have a significant effect on future planning and operations. This narrative report is submitted by the Defense Intelligence Agency (DIA) and normally addresses a single development, situation, event, or activity. The primary objective is to report an event, to explain why the event occurred, and to make an assessment as to what impact the event could have on the United States.

(2) *Special Defense Intelligence Notice (SDIN)*. The purpose of the SDIN is to provide the JCS, the unified and specified commands, the services, and selected agencies with timely intelligence regarding events that could have an immediate and significant effect on current planning and operations. This narrative report is submitted by DIA whenever a critical development appears imminent or is of unusually high interest to US decisionmakers. The primary objective of the SDIN is to report a critical event expeditiously, explain why the event occurred, and make an assessment as to what impact the event could have on the United States.

(3) *Spot Intelligence Report (SPIREP)*. The purpose of the SPIREP is to provide the JCS, the National Military Intelligence Center, the unified and specified commands, the services, and selected agencies with timely intelligence regarding events that could have an immediate and significant effect on current planning and operations. Unified and specified commands, services, and military units of divisional level submit this narrative report whenever a critical development appears imminent or is of unusually high interest to US decisionmakers. The SPIREP is due out as soon as possible, but not later than 1 hour after the information is received. Further, the report will not be delayed pending verification or the collection of additional detail. Amplification or clarification should be sent in a follow up SPIREP.

(4) *Commander's Situation Report (SITREP)*.

(a) The SITREP, as described in JCS Publication 6, volume II, is the report in which a commander identifies and provides his evaluation of significant factors which substantially improves or degrades his operational readiness or which may cause higher level policy adjustments. It is used to keep the JCS, the commanders of unified and specified commands, the services, and other appropriate agencies advised of existing situations of readi-

ness to meet the requirements of approved plans, and of the progress of ongoing operations.

(b) The SITREP is a narrative report formatted at the discretion of the submitting commander. A description of the type of data to be included in the report is contained in JCS Publication 6. Teletype is the standard means of transmitting the SITREP. It is implemented worldwide on a continuing basis and it is submitted to the next superior in the chain of command. Unified commanders submit this report daily. Other commanders submit a SITREP when and as directed by competent authority.

(c) The SITREP is directly related to the command and control function of military operations. It contributes to the identification of problem situations and to the evaluation of military capabilities. It overlaps the Commander's Operational Report (OPREP), but provides measures to prevent reporting redundancy by cross-reference techniques. The SITREP is an essential tool in the supervision of planned action in both peace and war.

(5) *Commander's Operational Report*.

(a) The OPREP, as described in JCS Publication 6, volume II, is the reporting system used to keep the JCS, commanders of unified and specified commands, the services, and other appropriate agencies advised of any event or incident which may attract national interest; of operational plans and current operations involving the employment or movement of military units; and of the results of associated air, sea, and ground activities. The system is designed to satisfy all echelons of command with a single reporting system.

(b) The OPREP is usually a narrative report which may be formatted at the discretion of the originator. Report samples and a description of the type of data to be included are contained in JCS Publication 6. Teletype is the standard means of transmittal; however, when the immediacy of the situation demands, the telephone may be employed. The OPREP consists of five reporting categories:

1 *OPREP-1, Operation Planning Report*. The OPREP-1 is used to describe planned operations for current situations.

2 *OPREP-2, Operation Start Report*. This report is used to advise that an operation has started or can be used to execute a plan or fragment of a plan.

3 *OPREP-3, Event/Incident Report*. This report is issued to immediately notify the National

Military Command Center (NMCC) of any event or incident which may attract national attention.

4 OPREP-4, Operation Stop Report. This report is used to advise of the completion of an operation or a phase of an operation.

5 OPREP-5, Operation Summary Report. This report is used to provide a statistical summary.

(c) Only the OPREP-3 is implemented worldwide on a continuing basis. It is submitted directly to the NMCC by any command level having knowledge of the incident and access to a communications network capable of relay into communications systems serving the NMCC. OPREPs 1, 2, 4, and 5 are submitted by such commands as are designated by the JCS, the commanders of unified and specified commands, or the services, and are implemented when and where operations may justify them.

(d) OPREP is directly related to the command and control function of the military organization. It contributes to the identification of problem situations and is an essential tool in the supervision of the planned action. When the nature of operations does not justify the implementation of OPREPs 1, 2, 4, and 5, plans and operations data normally associated with these reports are submitted in the SITREP.

(6) Unit Status and Identity Report (UNITREP).

(a) The UNITREP is the automated reporting system within DOD through which authoritative basic identity and status information concerning force units and organization is provided to the NCA and the JCS. Within the framework of UNITREP, the unique data requirements of the services, commanders of unified and specified commands, major service commands, and service component commands for organization/unit identity and status information are accumulated, refined, updated, and filed for rapid recall.

(b) UNITREP is an ongoing data resource. It consists of the UNITREP file which contains the identity of worldwide organization resources and selected data elements keyed to the Unit Identification Code (UIC) of each registered unit which describes uniquely their status; and the UNITREP which is used to keep the UNITREP file current. These data support operation planning and command and control functions within the OJCS, the Commander in Chief (CINC), the services, major service commands, service component commands, and DOD agencies. UNITREP is a primary source used to consider force availability. The nature of

status information demands that reports be prepared when status change occurs and forwarded without significant delay. The usefulness of UNITREP data in support of current operation planning and in monitoring current operations is directly affected by the timeliness and degree of accuracy with which the data are maintained.

(c) The requirements of computer processing demand precise formatting and adherence to precise formatting rules. Reporting format, data element definitions, and rules for their employment are contained in JCS Publication 6.

(d) The primary medium for UNITREP submission is by automatic digital network (AUTODIN) with a backup system using the Worldwide Military Command and Control System (WWMCCS).

(e) The UNITREP contains basic identity, general status, personnel strength, combat readiness, equipment and crew status, and other elements that present a picture of the unit and its daily readiness and capabilities.

(f) UNITREP is supported by and interfaces with the specified Geolocation Code File (GEOFILE), the Unit Type Code File (TUCHA), and the Major Equipment Code File (MEQPT).

(g) Through the WWMCCS Intercomputer Network (WIN), UNITREP provides support to the Joint Operation Planning System and the Joint Deployment System (JDS).

(7) JOPSREP.

(a) JOPSREP, as described in JCS Publication 6, volume II, is a communication system which lists standard element descriptions, criteria for editing, and procedures. It specifies formats and establishes what information needs to be collected to solve planning problems. For certain data that are not readily quantified, JOPSREP provides codes which are more easily assimilated by the computer. JOPSREP is used for reporting the Time-Phased Force and Deployment Data (TPFDD) among commands and agencies involved in joint operation planning.

(b) JOPSREP is structured for ADP and prescribes an integrated reporting system that assists in developing operation planning information to support the joint planning community—OJCS, JDA, the unified and specified commands, the Services, the TOAs, the Defense Fuel Supply Center (DFSC), and the Defense Logistics Agency. JOPSREP replaced the Deployment Reporting System (DEPREP), and did away with the use of computer punchcards as the means of manipulat-

ing/transmitting data. The data elements which make up the data base are arranged into eight functional categories. The categories provide logical data relationships as well as a means to discuss organizational responsibilities for data preparation in support of the joint operation planning process.

(c) A brief description of each of the JOPSP-REP data element categories is provided here. For complete data element formats and detailed descriptions of data to be entered into the data files, refer to JCS Publication 6, Volume II, Part II.

Force Requirement and Routing Force requirements and routing data provide force description information such as force requirement number (FRN), unit type code (UTC), unit level code (ULC), authorized strength, intermediate location, port of debarkation (POD), destination, load configuration, discharge constraints, POD arrival and destination required delivery dates, and the preferred mode and source of transportation to POD and destination.

Force Unit Identification Force unit identification data identify an actual unit (one having a UIC) or describe a type or notational unit designated to support the force requirement. Data include the unit origin, port of embarkation (POE) ready-to-load date, and transportation mode and source to the POE.

Force Movement Characteristics Force movement characteristics data address both unit personnel and unit cargo. Unit personnel data include the number of personnel requiring nonorganic transportation and the actual unit strength. Unit cargo data include the cargo categories of a force requirement and a detailed description of each type of item included within a cargo category. Cargo movement characteristics include weight, cube, square feet, and dimensions (length, width, and height).

Service Force Definition Supplement Service force definition data provide additional information necessary to define fully the force requirement. Use of these data are optional and will be based upon Service directives.

Nonunit-Related Cargo Characteristics and Routing Nonunit-related cargo data describe a cargo category providing organization, type of movement, and routing data. The cargo movement characteristics include weight, cube, and square feet.

Nonunit-Related Personnel Characteristics and Routing Nonunit-related personnel data describe the number of personnel, providing organization, type of movement, and routing data.

Movement Tables

Movement table data provide information concerning the planned movement to the POE, intermediate location, POD and destination. Data are prepared for each force requirement and each nonunit-related personnel or cargo requirement. Transportation mode and source, tons of cargo, number of personnel, departure and arrival dates, and locations are given to each requirement movement. Movement table data are also used to indicate movement requirements that cannot be met (those which exceed lift resources or port capabilities on the date required).

Remarks

Remarks data are used to provide additional information or comments pertaining to any other TPFDD entry.

4-16. Worldwide Military Command and Control System

WWMCCS is a DOD-approved network of command and control systems and subsystems. It consists of facilities, equipment, procedures, and personnel essential to a commander for conveying data used in planning, directing, and controlling military operations pursuant to the missions assigned. Formatted data facilitate the dialogue among commanders and enhance rapid reaction and timely military operations in the national interest. The system is readily adaptable for use under conditions involving requirements from increased military readiness through general war. Procedures consist of pre-positioned fragmentary instructions and other techniques which facilitate the transmission of selected command control data and precise military orders. These procedures serve to leave no doubt as to the action to be taken and the parameters within which military operations are to be conducted. The objectives of WWMCCS are to provide a means to:

- a. Supply timely data to properly constituted authorities in order to permit sound and effective decisionmaking.
- b. Facilitate timely response by military forces.
- c. Control the commitment and application of force in support of national objectives.
- d. Manage the use of supporting resources.
- e. Insure the continuity of essential military functions and operations.

Section IV. THE ARMY PLANNING SYSTEM

4-17. Introduction

a. To accomplish its basic mission, the role, philosophy, and doctrine of the Army are used to determine planning requirements. Land, sea, and air components of US military forces are employed under unified command and direction. The US Army is responsible for sustained operations in a land environment. Areas of actual and potential conflict and the range of possible roles of employment are ever changing. US Forces must be able to conduct successful operations in widely varying situations, including operations in which nuclear, biological and chemical weapons are employed. US military strategy provides for forward deployed forces and viable reinforcement of these forces from the United States or other areas of deployment. The projection of Army forces overseas requires strategic airlift and sealift which are not organic to the Army and must be provided by the US Air Force and US Navy.

b. Basic Army doctrine emphasizes mobility, flexibility, and staying power, so that the Army is maintained in a state of combat readiness for "any war, anywhere, anytime, in any manner."

(1) The anytime—anywhere aspect of Army doctrine calls for the ability to move rapidly to the scene of action. Strategic mobility is indispensable to executing these responsibilities. Whether a threatened aggressor is dissuaded or actual aggression is promptly dealt with depends on speed of reaction. This ability to be at the trouble spot when needed—preferably before fighting breaks out—is in part provided by forward deployment to critical areas. By pre-positioning forces and their essential military supplies and equipment in strategic areas worldwide to support Army forces, strategic mobility can be enhanced.

(2) The anywhere—anywhere facet of Army doctrine requires readiness for combat in any terrain or climate, under whatever conditions the geography, the enemy, or the nature of United States and allied objectives may impose. When the United States is faced with aggression or the threat of aggression, it must be able to call upon its military establishment for force which is appropriate to the requirement. The Army is prepared to fight with nonnuclear weapons, or to use nuclear firepower. To fight and win on the Airland Battlefield, the Army must be prepared to employ nuclear and chemical weapons decisively. Survival of personnel and equipment and recovery from injury or damage are essential to continued operations in a nuclear chemical environment. The possibility that land combat operations may be

conducted in any terrain or climate is reflected in the Army's organization. US Army forces engaged in combat with the enemy must be sustained. The Army in the field is, therefore, composed of units which perform combat, combat support, and CSS functions. The combat forces are composed of infantry, armor, field artillery, and air defense artillery units. Combat support forces are composed of engineer, signal, military police, and military intelligence units. Combat service support is provided by adjutant general corps, finance, quartermaster, medical, chaplain, judge advocate general, ordnance, chemical, and transportation individual elements or units. There are seven different types of divisions: armored, airborne, infantry, light infantry, air assault, high technology motorized and mechanized. The corps is the largest unit that has combat support and combat service support units.

(a) No major combat unit is limited by organization, training, or equipment to operations in a specific area or under special conditions. The division, the basic combat unit, is an integrated team of the combined arms and services, self-contained and capable of independent operations, nuclear or nonnuclear. It is tailored to meet the requirements of specific missions and areas of conflict by appropriate assignment of combat maneuver battalions. Any major combat unit, from the corps down to the brigade and separate battalion, can be reinforced with artillery, armor, or infantry.

(b) The Army concept of organization for combat is to tailor divisions and corps to battle-field requirements. Nonvisional units are assigned to corps and are available for attachment of the division or for support of the division. For the Army planner, this poses certain problems. Since units are nonstandard, the use of notional units in planning must be undertaken with caution. The size, composition, points of origin, and other characteristics of the real or actual units may vary widely from characteristics of notional units. In determining the proportion of combat, combat support, and CSS components in a force under varying conditions, the Army concept in every case is to provide the maximum combat force, with only the essential sustaining component. Modern war, with its complex equipment and tremendous consumption of materiel, has resulted in a high-sustaining proportion in all modern armies. The problem of balance is of continuing concern to the Army planner.

(3) If the Army is to support national objectives, it must be capable of prolonged operations,

in conjunction with other services, regardless of the circumstances and conditions surrounding the employment. The ability to conduct sustained land combat to include a nuclear chemical environment, is a major element of Army doctrine. To achieve staying power, combat and combat support forces must be sustained for the duration of the operation. Supplies, construction, repair, maintenance, and other support items are required to continue operations. The support components of a balanced force operate from the shoreline forward. Some units are in the combat zone (CZ) itself, while others operate to the rear of the CZ, in the communications zone (COMMZ). The latter may operate over large territorial areas with long supply lines from the water and air ports of entry to the CZ, posing significant supply and transport problems for the planners.

c. Army planning by its nature is complex and detailed and must provide for various possible situations and contingencies. CSS planning, especially that pertaining to supply, maintenance, and transportation, requires specific attention to details, especially determination of what is required to support a particular operation. CSS planning and the providing of CSS will be increasingly complicated in a nuclear chemical environment.

4-18. The Army Planning System

a. The DA planning system, including the documents produced by the system, is designed to provide an Army analysis of the worldwide threat; plan the effective utilization of forces and resources currently available and task the appropriate Army commanders with the execution of the plan; develop the Army objective force and resource requirements to support the forces; and structure the approved Army forces and resources to execute the approved strategy and to achieve the military objectives.

b. Strategic planning in the Army is done in conjunction with the JSPS (see paragraph 4-12). Through the JSPS the Army provides its input to the joint documents representing JCS advice to the Secretary of Defense and the President. The Army receives its force planning guidance via this same system—and participates in development of that guidance through providing Army input. The Army maintains a family of three basic planning documents.

(1) *Army Strategic Appraisal (ASA)*. The ASA is a basic strategy document utilized in Army Staff planning. It presents the critical strategic issues and suggests Army initiatives for addressing those issues. The ASA serves as a basis for the development of the Army's input to OSD/JCS formal

planning documents. It addresses the midrange period (5-10 years) and provides a source of Army views on military policies and strategy based on Presidential, NSC, and OSD pronouncements. The ASA is organized on a worldwide and regional basis, and contains identification of national security interests and objectives and major national security policies; an analysis of the threat to United States interests and objectives and identification of gaps in required intelligence; and regionally oriented appraisals, strategic concepts, and military objectives to achieve the national security objective.

(2) *The Army Plan (TAP)*. The Army Plan is based on the ASA, applicable portions of the previous year's DG, and the JSPD. It provides guidance and priorities to Army planners and programmers for development of Army forces and support programs based on SA/Chief of Staff Army (CSA) objectives. These objectives are constrained by projected fiscal and manpower resource availability. The guidance is presented in terms of force structure.

(3) *Army Mobilization and Operations Planning System (AMOPS)*. The AMOPS provides guidance to Army Staff agencies, Army commands, and Army components of unified commands for the employment and/or support of Army forces in the short-range period. It reflects specific tasks and capabilities attainable within existing programs and budget limitations. The AMOPS uses the planning assumptions of, and provides for the Army implementation of the JSCP which, in turn, provides JCS guidance to the commanders of unified and specified commands and the service chiefs for the short-range period. The AMOPS documents the Active Army forces available to execute OPLANS; presents the mobilization schedule and forces together with planned availability for development of these forces; presents joint strategic concepts; assigns tasks to commanders of MACOMs; provides personnel, intelligence, and logistics guidance; provides guidance for special operations, with and without mobilization; and provides guidance required to plan for mobilization of units and individuals to meet established force requirements in event of the need to expand the Active Army. The AMOPS outlines the Army's concept and role in security assistance and is reviewed annually and republished biennially. DCSOPS has Army Staff responsibility for preparation of the AMOPS.

c. The Army Planning System described above is the first phase of the Army Planning, Programming, Budgeting and Execution System (PPBES). It is

that component system of the Army resource management function performed at HQDA which addresses the development of national military strategy, policy, force objectives, force capabilities, and resource requirements in the execution of Army roles and missions. It does not specifically address military operations planning as performed by the Army component commander or a unified/specified command, but assists in providing a basis for planning to develop forces and necessary resources required to accomplish national security objectives. Most contingency planning responsibilities, other than providing policy guidance, establishment of requirements and priorities for utilizing Army forces and materiel and determining strategic mobility requirements, strategic mobility planning, and formulating base development policies, have been delegated to MACOMs and Army component commanders of unified commands.

d. As exceptions, The Surgeon General (TSG) is responsible for health service support planning and the Chief of Engineers accomplishes base development planning for Army component commands. The Commander, US Army Materiel Command (AMC), has been designated DA's single point of contact and coordinating authority for providing resupply support (less medical) and is charged with logistics and planning support of US Army Forces Command (FORSCOM) forces, Army elements of unified and specified commands, and other designated United States and foreign forces for contingency or wartime operation. The Commander, FORSCOM, as CINC, US Army Forces Readiness Command (CINCARRED) and CINC, US Army Forces Atlantic (CINCARLANT), when activated by the Chief of Staff, Army, is the DA's coordinating authority in support of deployment plans and operations and is the single point of contact for USCINCREC and Commander in Chief Atlantic (CINCLANT) for the planning of provisioning of administrative and logistics support of US Army forces under the operational command of the respective unified command. The Commander, US Army Western Command (WESTCOM) is responsible for the preparation of plans in accordance with the current Commander in Chief, Pacific (CINCPAC) guidance manual, preparing Primary US Army supporting plans (not the responsibility of other MACOMs) required to support HQ, Pacific Command (PACOM) plans; and review Of plans as assigned or requested by CINCPAC. Army component functions for US Southern Command (USSOUTHCOM) are carried out by the 193d Infantry Brigade. Army component functions for the US European Command (USEUCOM) are carried out by the US Army, Europe (USAREUR).

e. Policies and guidance for planning of the unified/specified command and Army component command levels are stated in JSC Publication 3 and the JOPS. The Army-in-the-field policies, guidance, and data are published in FMs 100-10, 101-5, 101-10-1, 101-10-2, certain FMs and TMs covering functional areas, and supply bulletins. However, policies and guidance for planning at MACOM and installation level must be gleaned from numerous sources. MACOMs and TSG publish logistics policies and guidance for use within their own activities.

f. The Commander, FORSCOM/CINCARLANT/WESTCOM conducts planning in support of US CINCREC/CINCLANT/CINCPAC. He may designate planning agents to develop plans or to execute specific tasks for deployment, employment, and/or support of Army forces. His responsibilities include:

(1) Maintaining Reserve or combat-ready Army forces.

(2) Designating units to fill force capabilities requirements.

(3) Developing force packages to support contingency plans.

(4) In accordance with DA guidance, prescribing unit priorities and authorized levels of organization.

(5) In accordance with DA and USCINCREC guidance, prescribing readiness standards of US Army Forces, Readiness Command (USARRED) units.

(6) Announcing deployability criteria for USARRED units.

(7) FORSCOM Headquarters concentrates on deployment aspects of a plan. Planning for tactical employment is accomplished by the tactical employment agent. The Commander, FORSCOM/CINCUSARRED/CINCARLANT conducts planning essential to the deployment of forces and the continuing support, if required, of these deployed forces. The Commander, FORSCOM/USCINCARRED may perform planning support of unified commands other than USREDCOM and LANTCOM. Coordination of deployment planning with the other unified commands also is accomplished by Commander, FORSCOM/CINCUSARRED. Planning agents may be tasked to perform employment planning for operations in an objective area.

Section V. CONTINUITY OF OPERATIONS PLANNING

4-19. General

a. Certain organizations, agencies, and activities of the US Government, because of their vital roles in Government operations and interest in national security, must maintain an uninterrupted capability to perform primary missions. The heads of Government organizations and commanders of military forces down to the lowest echelons are responsible for insuring that adequate measures are taken to prevent or minimize interference with their operations. These measures include the formulation and dissemination to subordinates of detailed rules, procedures, plans, and methods of operation. The measures are based on those of higher authority and are coordinated with those of parallel echelons.

b. Within DOD, war emergency planning is accomplished to provide guidance, task assignments, and courses of action to be followed by DOD components under limited and general emergency conditions to survive and recover from a Continental United States (CONUS) disaster due to enemy action and continue to respond to requirements by accomplishing essential missions.

4-20. DOD Policies

a. It is DOD policy that commanders plan for continuity of operations. This responsibility includes readiness testing of the plan.

b. Continuity of operations planning (COOP) responsibilities include:

(1) Planning for and establishing the best organization or command structure to continue operations.

(2) Determination of functions essential to the operation.

(3) Programing and funding readiness testing.

(4) Publishing the doctrine for continuing operations within the command.

c. COOP is conducted as one phase of mobilization planning. In this respect, it is necessary to correlate all aspects of mobilization planning with COOP. Of particular importance is the impact of the sudden activation of COOP on the ability of DOD components to meet manpower and materiel requirements after mobilization is ordered.

d. Planning by unified/specified commands and their subordinate elements is based on missions and forces assigned. The establishment of alternate command posts is the principal measure used by these commands.

e. The subsystems of the WWMCCS through which operational direction and technical/administrative support is provided a given command must provide continuity of command/operations to the level of conflict the forces can deter or counter effectively.

4-21. Planning Basis

a. COOP is based on several attack conditions and periods before and after the attack. There is no assurance of warning of an attack or that a warning would be acted on. It is quite likely that before any attack there will have been a period of extremely tense situations and dangerous actions. All commands/activities performing vital functions to the continuity of DOD and Federal Government operations must plan in preparation for any contingency that might occur. Because one condition assumes no warning prior to a surprise attack and another assumes adequate prior warning, plans must be developed for both.

b. Regardless of the condition under which an attack occurs, emphasis during the attack is placed on continuing essential military operations and logistical support functions. Damage control procedures should be initiated as well as efforts for the maintenance and restoration of law and order. Efforts will be directed to the support of civil defense and the assessment of damage and residual resources.

c. COOP must also address the postattack period. These must include the immediate phase, which is concerned with survival activities, military operations, mobilization of military and civilian manpower and resources, restoration of essential communications, transport, and limited procurement and production of essential items. Following this, planning must be directed to rehabilitation, restoration, and restructuring of remaining resources.

CHAPTER 5

JOINT OPERATIONS PLANNING

Section I. INTRODUCTION

5-1. General

a. The Joint Strategic Planning System (JSPS), the Joint Operations Planning System (JOPS), and the Army Planning System were discussed briefly in chapter 4. The JSPS provides for the publication of timely documents and guidelines that permit the development of contingency plans. The JOPS provides guidelines on how to put the plans together. There is a sequence of events that occurs from year to year that accommodates changes in planning and provides for updating plans. This sequence of events incorporates the publication of documents under JSPS and is integrated with the defense Planning, Programming, and Budgeting System (PPBS). It is the integration of JSPS and PPBS that permits recommendations to be passed from the Joint Chiefs of Staff (JCS) to Secretary of Defense, National Security Council (NSC), and the President and decisions and guidelines to be passed from the Secretary of Defense to the JCS, the services, and unified and specified commanders. Concern with the process of developing contingency plans down through division level in the Army requires a look at those documents published that provide communication up and down to assist in the planning process and to close the gap between resource managers, strategic planners, and contingency planners.

b. The participants in the contingency planning cycle below the JCS are the unified and specified commands worldwide that prepare contingency plans as directed in the Joint Strategic Capabilities Plan (JSCP) and the supporting component commands which respond to the unified and specified commanders with supporting plans. In addition, subordinate unified and specified commands when established, such as in Pacific Command (PACOM), prepare supporting plans as directed by their unified or specified commands. Eventually, corps and divisions write supporting plans to carry out detailed missions. To fully understand the interaction of cycles and participants, it is necessary to review the unified and specified commands with which the Army must work in developing contingency plans and supporting those plans.

(1) A unified command is a joint force, with a broad continuing mission under a single commander, which is composed of significant assigned or attached components of two or more services, and which is constituted and so designated by the JCS or by a commander of an existing unified command which was established by the JCS. Unified commands currently constituted are:

(a) US Atlantic Command (USLANTCOM) with headquarters at Norfolk, Virginia.

(b) US European Command (USEUCOM) with headquarters at Patch Barracks, Stuttgart, Germany.

(c) US Pacific Command (USPACOM) with headquarters at Camp H. M. Smith, Oahu, Hawaii.

(d) US Readiness Command (USREDCOM) with headquarters at MacDill Air Force Base, Tampa, Florida.

(e) US Southern Command (USSOUTHCOM) with headquarters at Quarry Heights, Canal Zone.

(f) US Central Command (USCENTCOM) with headquarters at MacDill Air Force Base, Tampa, Florida.

(g) US Space Command (USSPACECOM) with headquarters at Colorado Springs, Colorado.

(2) A specified command is a uniservice command with a broad continuing mission, which is established by the President and is specified as a command operating under the direction of the JCS and responsible through the JCS to the Secretary of Defense and the President. Elements of other military services may be assigned to the operational control of a specified command in the performance of its mission. Specified commands currently constituted are:

(a) Strategic Air Command (SAC) with headquarters at Offutt Air Force Base, Omaha, Nebraska.

(b) Aerospace Defense Command (ADCOM) with headquarters in Colorado Springs, Colorado.

(c) Military Airlift Command (MAC) with headquarters at Scott Air Force Base, Illinois.

(3) Army component commands within each unified command or subordinate unified command, if established, are designated as the US Army forces component of the appropriate command. The Army is commanded by the senior Army officer eligible to exercise command. Army forces assigned to a unified or specified command are organized by the Department of Army (DA) to support accomplishment of the unified or specified command mission. Existing US Army component commands are:

(a) USAREUR, with headquarters at Campbell Barracks, Heidelberg, Germany, is the Army component command of USEUCOM.

(b) United States Army, Atlantic (ARLANT) and US Army Forces Readiness Command (USARRED) serve as the Army component of LANTCOM and USREDCOM. The US Army Forces Command (FORSCOM) with headquarters at Fort McPherson, Georgia, also has the mission to function as ARLANT and USARRED component.

(c) US Army Western Command with headquarters at Fort Shafter, Oahu, Hawaii, performs Army component command planning functions for USPACOM. Actual Army component command responsibilities in wartime depend upon whether the conflict is regional or global in nature. In a global conflict, or one that is regional but not in Korea or Japan, WESTCOM continues its component responsibilities. In event of a conflict restricted to Korea or Japan, Army component command responsibilities would be assumed by the Army component of the appropriate subunified command. There are two subordinate unified commands in USPACOM:

1 Commander United States Forces, Korea (COMUSKOREA) whose Army component is Eighth United States Army (EUSA).

2 Commander United States Forces Japan (COMUSJAPAN) whose Army component command is United States Army, Japan (USARJ).

(d) The 193d Infantry Brigade, a subordinate command of FORSCOM serves as the Army component command of USSOUTHCOM.

(e) US Army Forces Central Command (USARCENT), composed of the Third US Army, is the Army component command of USCENTCOM.

5-2. Unified Command Plan (UCP)

The UCP assigns specific geographic areas of responsibility to commanders of unified commands

or specified commands around the world. Certain geographic areas are not covered by unified commands. The responsibility for planning for contingencies in these areas is given to the USREDCOM or is undertaken by the JCS. In the preparation of contingency plans, unified commanders are responsible for their assigned geographic areas and plan to take control of forces not already in their assigned areas as they enter the area. The assigned areas of responsibility are those that are the most logical considering the threat, strategy, current location of US forces, and agreements with allies. Unified commands prepare contingencies for operations in all parts of their assigned areas of responsibilities where there is a logical threat or mission. These plans are either written as a result of instruction contained in the Joint Strategic Capabilities Plan (JSCP) or other JCS directives or they are written unilaterally by direction of the unified commander.

5-3. Planning Levels

Planning at the service department and Department of Defense (DOD) levels is concerned primarily with determining resources to carry out national strategy and in providing guidance to lower echelons for their planning. At the JCS and the unified command levels, planning is concerned primarily with deployment of forces rather than their employment. Employment is considered only to the extent of determining the deployment requirements. At these high levels, the planners must be able to project themselves into the future from 1 to 10 or more years. At the JCS and unified command levels, the planners must also consider joint aspects. At the component command level, the concern is a miniature of that at the service department, unified command, and major commands subordinate to the service levels. Below the component level the concerns are principally uniservice with limited territorial responsibilities and in the near time frame. Regardless of the level, all planners, in developing plans, proceed in a deliberate and logical fashion to examine and define the problem and develop a solution. Regardless, if the final product is a complete, formal written document, an abbreviated document, or informal verbal presentation, the general sequence of steps and format for the end product is followed. For the joint planner, the JOPS should facilitate planning through the use of standardized files and procedures and automatic data processing (ADP) support. The standard files act as a common denominator to have all services utilizing the same data and talking the same language. With the whole system built around the Worldwide Military Com-

mand and Control System (WWMCCS), the JCS, services, Joint Deployment Agency (JDA), and Transportation Operating Agencies (TOA) have access to a common data base for all items. The

ADP capability not only aids in operation planning but also in review of the plans and the feasibility testing of them.

Section II. DATA AUTOMATION SYSTEMS TO SUPPORT JOINT OPERATIONS PLANNING

5-4. General

a. Joint planning has become increasingly dependent upon ADP. Detailed, precise planning and feasibility testing are imperative because of limited resources, the dramatic increase in the price of forces, weapons systems and their support, and the decreased margin of military superiority and strategic and tactical warning. The constraints of limited strategic and tactical transportation resources, together with the increased demands placed on mobility planning for contingencies throughout the spectrum of conflict, make planning and testing especially imperative. Rapidly developing crisis situations throughout the world require the military planner to respond accurately and almost instantly to queries by the National Command Authorities regarding the widest range of options and possibility for the application of US military forces. The satisfaction of these requirements is made possible through the use of second- and third-generation computers which enable the storage, sorting, and manipulations of tremendous amounts of data. Planners have access to rapid, secure communications systems for data exchange. They have also developed experience in writing and operating sophisticated software. Planners and commanders can now make realistic and detailed appraisals and evaluations of force requirements for the employment of combat and combat service support (CSS) elements as well as the major combat forces. It must also be pointed out that the ability of ADP to be a useful planning tool is highly dependent on hardware and software compatibility between systems.

b. The Office of the Secretary of Defense and the JCS have developed five primary systems to provide responsive standard systems and data. These five systems: the Joint Operations Planning Systems Report (JOPSREP), Worldwide Military Command and Control System Intercomputer Network (WIN), WWMCCS, JOPS III, and the Joint Deployment System (JDS), combine to give the planner the information system, computer hardware, and data files and programs necessary to develop feasible joint plans for both deliberate and time sensitive planning.

(1) The JOPSREP provides for a computer-computer exchange of force data. Army unique

requirements for the preparation and construction of force records in Operation Plan (OPLAN) Time-Phased Force Deployment Data (TPFDD) are prescribed in the Army Mobilization and Operational Planning System (AMOPS). The Army component, develops TPFDD for submission to the supported commander (unified, specified, or joint task force) in accordance with JCS Pub. 6, vol. II, pt. 11, ch. 1 (JOPSREP). The TPFDD includes assigned forces, augmentation and support forces, sustainment, and personnel requirements to be deployed in a theater of operations. The data are available to all supporting commanders and services responsible for developing supporting plans and annexes.

(2) The capabilities of WIN allow commands to use computer internetting. Computer internetting provides an opportunity to use workload sharing as computer work is transferred from a computer that is being used to the maximum to one that is not; allows an ADP user at one location to use ADP programs at a different location or the user can collect data stored at the second site for use at the home site; allows the ADP user to transfer data between computers, and allows teleconferencing among a large number of participants via a remote terminal.

(3) The WWMCCS was formalized by title, composition, and function by DOD Directive S5100.30 in 1962. As defined in JCS Pub. 2, WWMCCS is "the system that provides the means for operational direction and technical administrative support in the function of command and control of US Military Forces." The goal of WWMCCS is to assure effective connectivity among the National Command Authority, JCS and other components of the National Military Command Structure (NMCS) down to the Service component commanders. The system provides a multi-path channel of secure communications to transmit information from primary sources to those who must make decisions (including presidential decisions) and to transmit their decisions (in the form of military orders) to subordinates. The five major components of WWMCCS are the National Military Command Structure, the WWMCCS-related management/information systems of the headquarters of the military departments, the com-

mand and control systems of the unified/specified commands, the command and control systems of the headquarters of the service component commands, and the command and control support systems of the DOD agencies.

(4) JOPS Automatic Data Processing (ADP) is a standard system to provide automated support to the joint planner during plan development, review, and execution. The technical aspects of JOPS ADP files and application programs are of no special interest to the average joint planner. The planner must, however, understand what the major files and programs are, and what they can provide. Files currently in JOPS provide planning data regarding characteristics of bases throughout the free world, construction, transportation resources characteristics, movements data, and resupply and personnel replacement data. In addition, there are eight programs which permit the planner to accomplish such tasks as tailoring forces, producing JOPSREP records, determining movement requirements, determining base development requirements, determining medical support and aeromedical evacuation requirements, and producing TPFDD. Another program permits the planner to determine the feasibility of the deployment scheme developed in support of the operation plan (OPLAN). A control program provides the planner the ability to work directly with the computer in a conversational model to change parameters, select options, and to specify the desired output relating to force structure, movements, and the feasibility of the deployment plan. The JOPS ADP programs are described in paragraph 5-5.

(5) The Joint Deployment System (JDS) was developed by the Joint Deployment Agency (JDA), as an automated system to support deployment planning and execution. Previous command post exercises by the joint community highlighted the need to tie together various computerized planning and execution systems and to augment existing management information systems. As a result, JDS-unique software capabilities and procedures were developed to operate with the Joint Operations Planning System (JOPS) and with the Unit Status and Identity Reporting System (UNITREP). By providing the critical link between forces needed (identified during the planning process) and forces available (identified by unit reporting), JDS bridges the gap between JOPS deliberate planning and time-sensitive planning and execution.

5-5. JOPS ADP Reference Files and Application Programs

a. JOPS, Volume III, is the manual that describes the ADP systems that have been designed

to support operations planning as specified in JOPS, volumes I and II. The ADP system has been developed as a WWMCCS standard system using Honeywell computers in DOD. The system is comprised of standard reference files, application programs and procedures which support the unified and specified commands, the services, TOAs, and the Organization of the JCS in accomplishing operations planning. The JOPS ADP computer programs have been designed to be dependent upon a continuous dialogue between the planner and the computer through a visual information processor (VIP) terminal.

b. The System Monitor (SM) provides the medium that allows the planner to work with the application programs in the JOPS ADP system. Responding to a series of preprogrammed questions displayed on the VIP terminal screen, the planner inputs the requested information using the terminal's keyboard and is led by the System Monitor through the planning process, step by step. The SM will convert the planner's inputs into the format necessary for an ADP program to recognize, store, and manipulate the data in the plan TPFDD. Likewise, the planner can ask for information from the TPFDD, and the SM will interface with the data base to access and display the contents in the report format desired.

c. The following is a brief description of the major JOPS ADP data files:

(1) *Aerial Ports and Air Operating Bases File (APOINTS)*. Provides physical and operating characteristics of air bases throughout the free world. Data include runway weight-bearing capacity, load classification number, fuel availability, aircraft parking space, and storage capacity. Records are identified by a geolocation code.

(2) *Civil Engineering Files (CEF)*. Provides construction planning data used by application programs within the Civil Engineering Support Plan Generator (CESPG).

(3) *Characteristics of Transportation Resources File (CHSTR)*. Provides essential characteristics of airlift and sealift resources. Data are used to determine number and type of transport vehicles required to support one or more OPLANs. Airlift and sealift resources data include:

(a) Airlift-load classification number, utilization rates, passenger capacity, cargo capacity, average load/unload time for each aircraft and type.

(b) Sealift-average load/unload time, average speeds by ship category with various loading capacities.

(4) *Transportation Assets File (ASSETS)*. Provides available strategic lift resources by craft type by time period at predetermined ports of embarkation (POE); by source of lift, mobilization conditions, and quantity as stated in annex J, JSCP.

(5) *Port Characteristics File (PORTS)*. Contains physical and operating characteristics of free world shipping ports including size of port, depth of harbor entrance, number of berths available by ship type, storage capacity, and beach data. All ports records are identified by geolocation code.

(6) *Type Unit Equipment Detail File (TUDET)*. This file describes the physical characteristics of selected items of unit equipment, including all wheeled and tracked vehicles (self-propelled or towed) that are not palletized, non-selfdeployable aircraft that are not crated, floating craft (including amphibians), any item measuring more than 35 feet in one dimension, and all hazardous cargo.

(7) *Type Unit Characteristics (TUCHA) File*. Provides standard planning data on movement characteristics for unit personnel, equipment, and accompanying supplies associated with deployable units of fixed composition. All movement requirements are aggregated into categories requiring special handling during deployment: bulk cargo, over-size and out-size equipment, non-air-transportable cargo, and passengers. Each type of unit in the TUCHA is uniquely identified by a five-digit Unit Type Code (UTC).

(8) *Logistics Factors File (LFF)*. The LFF contains standard logistics planning factors used to compute resupply requirements and replacement personnel for deployed forces. Logistics factors are Service estimates based on historical data and can be adjusted according to the nature of the theater of operation and the anticipated intensity of combat.

d. The JOPS ADP software consists of application programs and a system monitor which allows the planner to manipulate data during the joint planning process. Working through the System Monitor data concerning the size and composition of each standard type unit are extracted from the storage files maintained within the WWMCCS, the planner uses application programs to build, modify, and maintain a Time-Phased Force and Deployment Data (TPFDD) file and its corresponding Summary Reference File (SRF). A TPFDD file contains the force list as it is constructed using JOPS. Together, the TPFDD and the SRF contain all of the force, logistic, and deployment data that support each OPLAN. Figure 5-2 illustrates ADP support of the planning process. The application programs are:

(1) *Force Requirements Generator (FRG)*. The FRG permits the planner to select, analyze, and

tailor a variety of force options and to produce an acceptable deployment scheme based upon the mission to be accomplished, the time available for deployment, and the transportation assets allocated. As the combat forces and their support units are selected for the plan, deployment data concerning the size and composition of each unit are extracted from storage files in the WWMCCS and JOPS ADP systems and are automatically added to the TPFDD for use in support and transportation planning.

(2) *Movement Requirements Generator (MRG)*. The MRG provides a capability to generate gross non-unit-related cargo and supplies based upon the forces to be supported and the duration of the planned operation.

(3) *Non-Unit Personnel Generator (NPG)*. The program provides the capability to generate gross non-unit personnel transportation requirements for replacement personnel in support of TPFDD forces in the area of operation.

(4) *Transportation Feasibility Estimator (TFE)*. The TFE permits the planner to determine the feasibility of the deployment scheme developed in support of the OPLAN. It compares movement requirements of deploying forces, supplies and equipment, and replacements with available transportation resources (both sea and air) while analyzing the reception and discharge capabilities of the airfields and seaports used for the deployment. Successive iterations of the program coupled with modifications to the original deployment scheme will result in a feasible OPLAN based on the optimum movement of the forces and cargo involved.

(5) *The System Monitor (SM)*. The SM is a control program through which the planner is able to interact directly with the FRG, the MRG, and the TFE in a conversational mode at a terminal during computer operation. It permits the planner to input and change planned parameters, select options, and specify the outputs desired using the direct interface. This program is particularly important because it makes it possible for a planner with little or no training in ADP to work directly with the computer.

(6) *Civil Engineer Support Plan Generator (CESPG)*. The CESPG helps the planner determine the amount of manpower, equipment, and materials needed to construct and upgrade facilities that support the forces in an OPLAN. The program also forecasts the need for repair of war damage. The CESPG interacts with a number of WWMCCS and JOPS ADP files to compute the civil engineering requirements which are published in the Civil Engineering Support Plan (CESP).

(7) *Medical Planning Module (MPM)*. The MPM provides the health service planner with the capability to determine gross medical-support requirements based upon a number of variables that are specified by the planner. These variables include the size of the force-at-risk, expected casualty-admission rates, and the command's evacuation policy. The MPM calculates time-phased requirements for medical personnel (by type), medical treatment (bed and operating rooms) facilities, medical equipment and Class VIII supplies, whole blood and fluids, and medical evacuation requirements.

e. To summarize, the contents of the JOPS, volume III data base can be categorized as follows:

(1) *Plans Data*. Data which describes forces, materiel, personnel, and movement requirements for OPLANs.

(2) *Status Data*. Data which describes current or programed posture of resources such as lift forces and mobility support facilities.

(3) *Factors Data*. Data which describes physical characteristics of equipment, airlift planning factors, and sealift planning factors.

(4) *Standard Reference Data*. Data which contain dictionaries, tables of values, and common application programs used in encoding, decoding, and manipulating data elements.

5-6. Transportation Operating Agency (TOA) Supporting Systems

Under JOPS, the TOAs are tasked to provide plan-unique data in accordance with JCS Pub. 6, Volume II. Although not formally a part of JOPS III, the TOA ADP systems support the joint planning function with command-unique systems to provide movement tables for the JOPS community (see also paragraph 6-17). These systems are:

a. *Military Airlift Command (MAC) Integrated Military Airlift Planning System (IMAPS)*. IMAPS is the MAC automated capability to develop airlift plans considering planning variables such as latest arrival date, availability of aircraft and crews, the most expeditious and efficient routing, and en-route staging or refueling bases. IMAPS is operated and maintained by MAC on the WWMCCS computer and uses airlift assets prescribed by the JSCP as being available for planning. During execution planning, airlift assets and availability are modified to reflect the current situation.

b. *Military Traffic Management Command (MTMC) Mobility Analysis and Planning System (MAPS)*. MAPS II is the MTMC automated capability to support JOPS actions and OPLAN requirements, including the preparation of move-

ment tables. The system designates the CONUS seaports and simulates scheduling of movements requiring commercial transportation from CONUS departure locations to air and sea POEs. MAPS II is used to address the CONUS transportation feasibility of OPLAN movements.

c. *Military Sea lift Command (MSC) Strategic Sealift Contingency Planning System (SEA COP)*. SEACOP provides MSC with computerized methods for determining the shipping resources needed to meet the cargo, troop, and petroleum, oil, and lubricants (POL) sealift requirements for OPLAN development. The system uses a predetermined ship data base, port characteristics data, and planning assumptions to determine number and types of ships required to provide feasibility to the sealift requirement of the OPLAN. During normal planning, MSC uses the JOPS III files prescribed by the JSCP as being available for planning. During execution planning, sealift assets and availability are modified to reflect the current situation.

5-7. Other Army ADP Systems

While not part of JOPS ADP, several ADP programs developed by Army commands are or can be used to provide support for Army planning under the JOPS. The following are some of the programs currently in use in the Army.

a. *CONFORM*. This model provides rapid, automated response in estimating theater CSS force requirements using a minimum of input data. It produces a quick estimate of the CSS force structure and its deployment tonnages. It also develops information on hospital requirements, consumption requirements, maintenance support, POL use, force costs, and port handling tonnages.

b. *SIGMALOG*. An indepth analysis of theater CSS requirements is provided by this model. This analysis includes an evaluation of theater stock levels, policies, and requirements. Information provided by this model includes a force list, casualty reports, hospital beds, supply consumption (including POL), stockage, and materiel maintenance requirements.

c. *FOREWON*. A computer-assisted automated planning system designed to assist the Army Staff in its determination of short- and wide-range requirements for division forces and certain special mission forces, and in predicting the capabilities of these forces. FOREWON consists of a Preliminary Force Design (PFD), Combat Simulator (ATLAS), Theater Roundout Model (FAS TALS), Objective Force Designer (OFD), and a Force Cost Assessor (FCA). The system accepts as input a set of world-

wide situations that call for the application of US military forces, and derives a single objective force competent to achieve desired military objectives. It is designed primarily to consider forces at the theater level.

d. Force Analysis Simulation of Theater Administrative and Logistics Support (FASTALS). FASTALS is a logistics or force roundout model which automates the computation of a balanced and time-phased troop list based on a given combat force and its theater-related activities. The resulting troop list consists of the minimum number of units required to provide complete support (based on the TOE capabilities of the units involved). It also locates units and their workloads in the division, corps, Army, or communications zone (COMMZ) areas. The model can calculate the different logistics workloads pertaining to personnel replacement, medical, materiel maintenance, transportation and construction functions, and allocates units to perform them. Given an employment situation, logistics capabilities and theater policies, FASTALS will determine the total force necessary to support the situation logistically. It can be used in any force planning simulation where a balanced, time-phased, geographically distributed force is desired.

e. Computerized Movements Planning and Status System (COMPASS). COMPASS is a data bank containing information on unit movement and transportability. It contains numerous items of Army equipment in a computer file which will give standard equipment characteristics such as

weight, cube, dimensions, and other pertinent data. The files are designed to provide unit commanders and logistics planners with information they need to execute mobility operations. These files include a wide variety of information such as a description of how to brace and block equipment on open top wood deck rail cars; numbers of military cargo aircraft required to move the force (C-141, C-5A); and many other kinds of information. COMPASS is described in FORSCOM Reg 55-1, Unit Movement Plans and Reports.

f. CASTLE. This system is known in the joint arena as the T-54 module. It was developed by the Engineer Studies Center, Office of the Chief of Engineers, HQDA, to assist in Army base development planning. It has been installed at the headquarters of oversea unified commands and at the JCS. The basic concept is that base development planning can be conducted at any unified command location. CASTLE calculates facilities requirements in support of joint contingency operations. On the basis of the TPFDL and other guidance in the basic OPLAN, CASTLE computes unconstrained facility requirements against existing facility assets within each deployment region. It also calculates facility shortages for essential facility type, including repair of estimated war damages. The system considers operational priorities and construction force capabilities and schedules construction projects with associated construction force and materiel requirements. The system develops a capabilities construction program in format and detail as prescribed in the JOPS.

Section III. THE JOINT PLANNING PROCESS

5-8. General

a. Unified Action Armed Forces (UNAAF) define the joint planning process (JPP) as a coordinated joint staff procedure used by a commander to:

- (1) Determine the best method of accomplishing assigned tasks.
- (2) Direct the action necessary to accomplish his mission.

b. In military planning, consideration must be given to all factors that can have a significant effect on the accomplishment of the mission of the command. Planning for anticipated contingencies is normally deliberate and formal; however, a requirement for rapid reaction in crises or emergency situations may dictate an acceleration of the planning process. Whether the plan results from an informal mental estimate by the commander or from a detailed formal staff analysis, the factors

which are considered remain unchanged. The scope, amount of detail, and the form of estimates depend on the size and importance of the task and the time available for planning.

c. An effective staff officer in the Joint Planning Process (JPP) must be well founded in his own service; possess a broad knowledge of the role, capabilities, and limitations of the other services; have a basic understanding of the planning systems for national defense; and be well versed in the following elements which play an essential role in operation planning:

- (1) The estimate of the situation is a logical process of reasoning in which all the circumstances affecting the military situation are considered and a decision as to the course of action to be taken is developed. It is a tool of the decision-maker.

(2) Operations analysis, also known as operations research, is “the analytical study of military problems, undertaken to provide responsible commanders and staff agencies with a scientific basis for decision on action to improve military operations.”

(a) Operations analysis involves a structured analysis of an operation or an element of an operation. The objective of operations analysis is to provide the decisionmaker a capability to examine scientifically a wide range of alternatives while employing selected data input variations and thereby identifying optimum model solutions. Solutions derived through this method are optimal only with respect to the model being used. If the model is well formulated (i.e., reflects a valid relationship to the real problem) the resulting solution should tend to be a good approximation of the best solution to the real problem.

(b) Operations analysis is particularly applicable in the JPP in the structuring of a balanced force list, the generation and forecasting of facility and resupply requirements, time-phasing of force, equipment, and materiel movement, transportation planning, the evaluation of relative combat power, the identification of shortfalls, the allocation of resources, feasibility testing of deployment, and support planning problems (particularly those which lend themselves to simulation or reduction to a mathematical model).

(c) Operations analysis techniques applicable in military planning are too numerous to treat individually in this publication. Some of the more useful are linear programming, dynamic programming, queuing theory, the inventory theory, Program Evaluation and Review Technique (PERT), probability theory, input-output analysis, sampling and statistical analysis, gaming, and simulation. (NOTE: DOD Directive 7041.3 contains definitions of certain techniques.)

d. The planning system approved by the JCS and directed for use in joint planning is JOPS. (See also paragraph 4-12d and paragraph 5-10.)

e. The Joint Reporting Structure (JRS) which is the approved reporting structure in which information, direction, and response regarding military operations are documented for transmission from, to, and between military commanders. (See paragraph 4-15 for discussion of the JRS.)

f. The WWMCCS is a DOD-approved network of command and control systems and subsystems. It consists of facilities, equipment, procedures, and personnel essential to a commander for conveying data used in planning, directing, and controlling military operations pursuant to the missions assigned. (See also paragraph 5-4 b(3).)

g. JOPS is the DOD-directed, JCS-specified system designed to accomplish global and regional joint operation planning. As such, JOPS establishes the processes to be used in both deliberate and time-sensitive planning of joint operations. JOPS is used to translate broad planning tasks into feasible plans. The two types of plans with which we are concerned are the OPLAN and the conceptual plan (CONPLAN). The OPLAN is complete when it contains all annexes and appendixes and can be translated into an operation order (OPORD) with minimum changes. OPLANs are normally developed for situations that will require maximum use of forces and logistics or mobility resources available and in instances where they are likely to be executed. The CONPLAN is an operation plan in concept format requiring expansion to an OPLAN or an OPORD prior to execution. Guidance as to whether a plan is to be an OPLAN or a CONPLAN is contained in the JSCP. Two terms commonly used to refer to major joint commanders are “supported Commander in Chief (CINC)” and “supporting CINC.” The commander of a unified or specified command is called the CINC. The supported CINC is the commander responsible for the development and execution of an OPLAN. The supporting CINC is the commander who provides forces and/or services to the supported CINC to satisfy OPLAN requirements. Those forces provided by supporting CINCs are referred to as augmentation forces.

5-9. The Planning Cycle

a. Military planning for the accomplishment of an assigned mission begins when the mission is assigned and ends when execution is ordered and the mission is accomplished or the requirement for the plan is canceled. Various types of planning documents are prepared by unified commands during the planning process.

b. Once developed and approved, a plan must be kept current. The plan should be revised, changed, or otherwise modified anytime the prevailing circumstances, forecast situation, or availability of forces or resources dictates. In addition to the requirement for updating plans on an ad hoc basis, the JCS require an annual review of existing plans. Command-unique requirements for the periodic review of existing plans are contained in local instructions. The maintenance and review of existing plans is normally the single most time-consuming task of the staff officer.

c. Threat estimates, force and resource allocations, and a wide variety of other significant planning criteria are forecast. Such forecasts are in-

formative but subject to change. An existing OPLAN may require adjustment to the prevailing circumstances prior to translation to an OPORD which can be implemented. Within the context of JOPS procedures, the planning cycle provides for the tailoring, expansion, and further development of such OPLANs as may exist and for their translation into OPORDs. The planning cycle accommodates the emergency development of an OPORD to fulfill a requirement for which no plan exists.

5-10. Phases in Joint Planning

The process of developing acceptable operation plans is described in JOPS as deliberate planning.

Within deliberate planning, there are five phases which are discussed in the following paragraphs. The process of developing operation orders is known as time-sensitive planning, and JOPS specifies a subsystem, the Crisis Action System (CAS) to speed up the joint planning process in an emergency. Time sensitive planning is discussed in paragraph 5-16. Figure 5-1 provides a brief description of the deliberate planning process phases and Figure 5-2 provides a graphic overview of the ADP support of the planning process. **Figure 5-2 (fold-in page) is located at the end of this manual.**

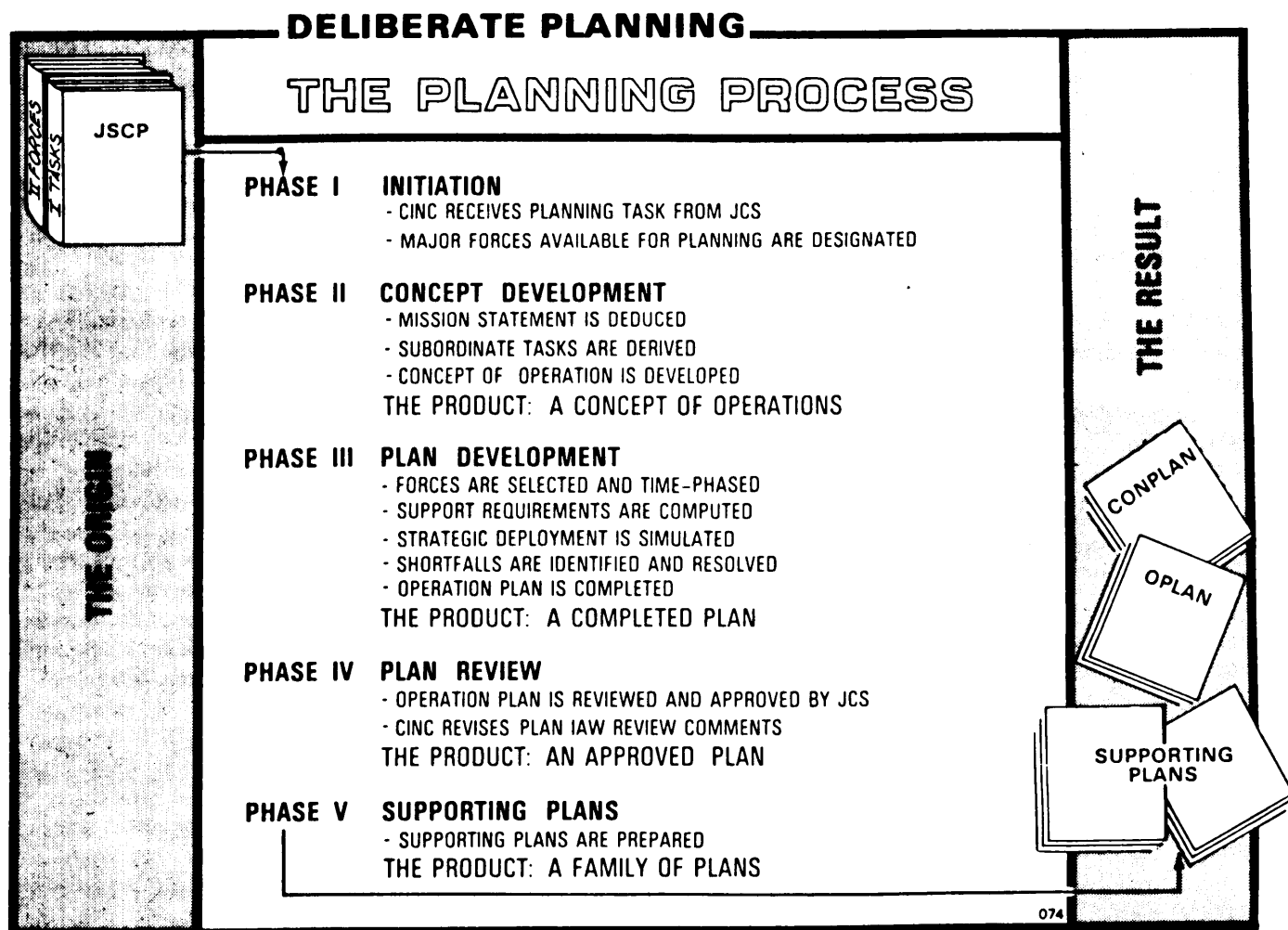

Figure 5-1. Phases of deliberate planning.

5-11. Initiation Phase

a. Action in the deliberate planning process is initiated by the JCS through processes inherent in the JSPS. Within the JSPS framework, the unified and specified commanders and the service chiefs receive planning direction and guidance, either explicit or implied. This direction and guidance is supplemented by related data contained in service planning documents and is the basis for planning actions by the unified and specified commanders. Planning tasks are assigned, forces and resources available for planning are identified, and the stage set for planning. Planning guidance provided by the JCS in strategic planning documents is applicable to all planning requirements regardless of the origin unless otherwise stated or additional information is provided by the JCS.

b. The JCS (normally by actions contained in the JSCP and the Joint Intelligence Estimate for Planning (JIEP)):

- (1) Provide strategic guidance and intelligence.
- (2) Assign tasks to the unified and specified commanders.
- (3) Identify major combat forces (by type, quantity, and timing) which are available for planning.
- (4) Identify JCS-control resources which are allocated for planning.
- (5) Identify the depth of planning required.
- (6) Assign priorities.

c. The services (normally by actions contained in service planning documents):

- (1) Designate other combat, combat support, and combat service support forces which are available for planning.

- (2) Provide guidance relative to the availability of replacement and filler personnel, materiel, equipment, and facilities.

- (3) Assign priorities.

- (4) Provide service doctrine and guidance.

5-12. Concept Development Phase

The concept development phase is that part of joint planning in which the commander responsible for the accomplishment of the mission (i.e., the supported commander) arrives at a decision as to the best course of action to be taken to accomplish his mission. The mission is analyzed, planning guidance is issued, information concerning enemy capabilities and the characteristics of the area of operations are assembled, and possible courses of action are identified. All factors having an effect on the accomplishment of the mission must be considered and the entire staff is used to estimate the influence of these factors on the alternative courses of action. Following analysis, the estimate is completed and the commander makes his decision. This decision is the expression of what the command, as a whole, is to do. The concept of operations is an expansion of the selected course of action into a broad narrative statement of how the commander expects the operation to unfold. Although the concept development phase will be explained in sequential steps (since such a procedure is necessary to clear understanding), there will be occasions when two or more steps are in process concurrently or when steps are retracted. For example, the results of preliminary work on one step may be taken back and used in the reworking of an earlier step. Keeping these words of caution in mind, the sequential steps of the concept development phase can be listed as: (See figure 5-3.)

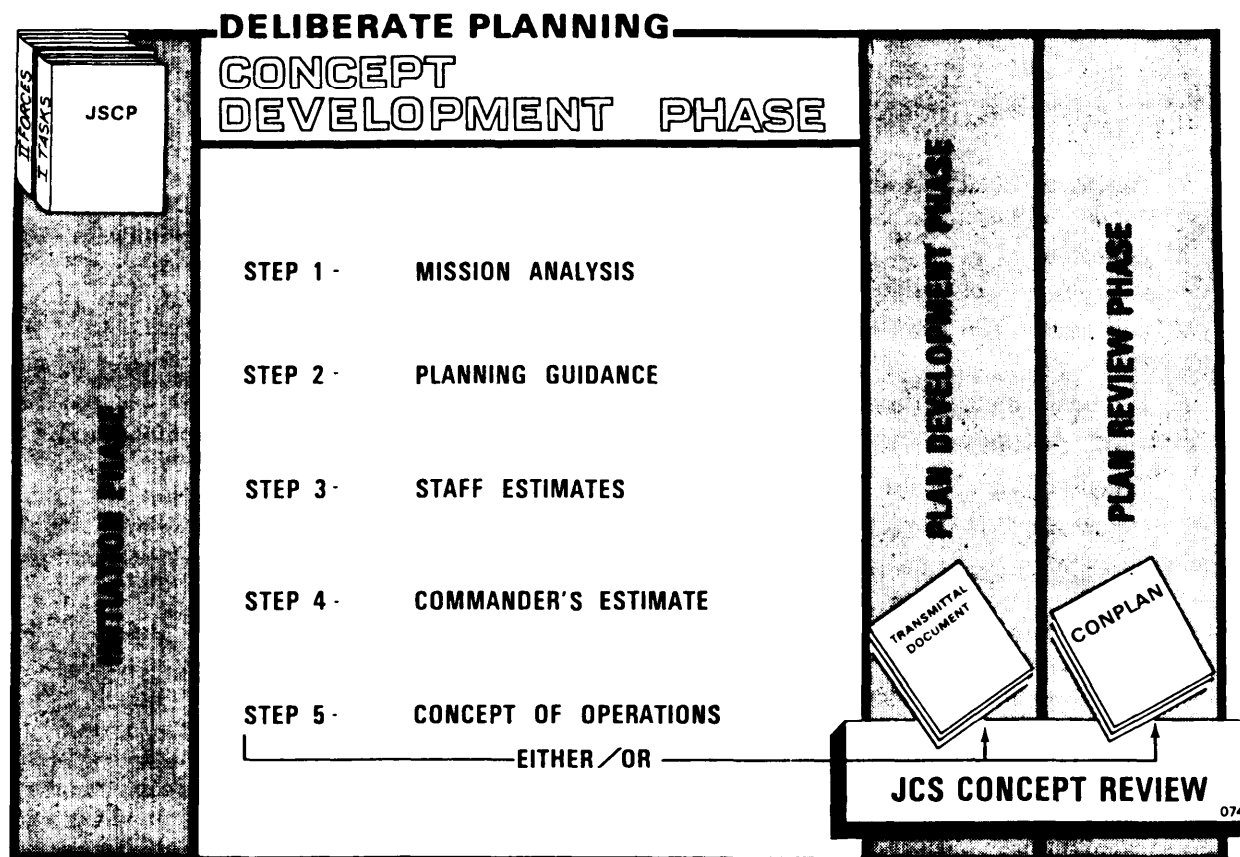

Figure 5-3. Steps in the concept development phase.

a. *Step I—Mission Analysis.* At this point it is necessary to have a common understanding of the terms “TASK” and “MISSION.”

TASK—An operational requirement imposed on a subordinate echelon. When properly met, it will contribute to the accomplishment of the mission of the issuing commander. Tasks are positively stated and include the elements of what, when, and where.

MISSION—The statement of the operational mission describes the objective. The mission is the task together with its purpose, thereby, clearly indicating the action to be taken and the reason therefor. It includes the who, what, when, where, some of the how, and why (the purpose of the operation).

(1) What are the missions and tasks?

(a) First the problem must be defined.

(b) At the lower levels, it is probable that specific tasks will have been assigned by higher authority in clear and precise terms that leave little room for interpretation. On the other hand, a higher echelon, such as a joint command, may find it necessary to deduce its mission and tasks from

circumstances, from directives which do not spell out missions and tasks as such, or from oral instructions received from higher levels of command or Government. In such cases, it is necessary for the staff to spell out in writing what it understands the commander's mission and tasks to be. After this is accomplished, it is advisable to insure that the commander agrees with its wording and that it is in keeping with his personal views or any special information or opinions he might have.

(c) Whether the task is assigned or deduced, it may be necessary to establish subsidiary tasks that flow from it.

(2) Statement of missions and tasks.

(a) Military missions and tasks should be phrased in language which clearly conveys the what, where, when, who, some of the how, and in the case of the mission, the why of the operation.

(b) Since missions and tasks will be used many times before the final OPLAN or order is written, they should be sound and agreed upon by both commander and staff from the beginning.

b. *Step II—Planning Guidance.*

(1) *Introduction.* This step has two main objectives:

(a) To provide the commander's staff with the following preliminary information and guidance:

1 A statement of the missions and tasks as the commander understands them.

2 A statement of the assumptions under which the operation will be conducted.

3 Guidance concerning nuclear and chemical warfare.

4 Political considerations.

5 Tentative courses of action.

6 The planning schedule.

7 Initial staff briefings.

(b) The second major objective of this step is to make the above information available to the staffs of subordinate commanders, supporting commanders, and TOAs as appropriate, in the form of a planning directive. As will become apparent in subsequent phases of joint planning, the commander's preliminary planning guidance may serve as an adequate basis for the early initiation of certain plan development actions such as force planning, support planning, and the Civil Engineer Support Plan (CESP).

(2) *Transmitting the Planning Guidance.* The commander can accomplish the transmission of this guidance in one of at least three ways:

(a) By holding a preliminary planning conference to which representatives of subordinate and supporting commanders and all concerned agencies are invited. He could give the briefing himself or have appropriate members of his staff give presentations conveying his thoughts and wishes. His chief of staff or other designated representative could also conduct such a conference.

(b) By issuing a written planning directive which would convey the same information to the participants in the planning process.

(c) By holding a preliminary planning conference and following it up a few days later with a written planning directive.

(3) *Components of the Preliminary Planning Guidance.*

(a) *Analysis of Missions and Tasks.* Discussed in paragraph 5-12a.

(b) *Statement of Assumptions.*

1 The DOD Dictionary defines an assumption as: "A supposition on the current situation, or a presupposition on the future course of

events, either or both assumed to be true in the absence of positive proof, necessary to enable the commander, in the planning process, to complete his estimate of the situation and make a decision on his course of action." Planning assumptions fill the gap in factual knowledge. The statement of assumptions concerning the operation at hand must be approved by the commander before any detailed work is undertaken.

2 An assumption is always stated as a fact. It should be kept in mind that an assumption must have three characteristics: it must be logical, it must be realistic, and it must be essential. A good measuring stick to test essentiality is: Is this assumption absolutely necessary to planning or for the successful completion of the plan? It is prudent to develop alternate plans in the event that the assumed condition or event does not occur as predicted.

3 As planning proceeds, the need for further assumptions may appear and some of the assumptions originally given during the planning guidance may prove to be untenable. New information may turn others into facts. When planning and preparation begin a relatively short time before the operation, there will be very few assumptions needed. As operations are projected further into the future, fewer facts are available and the planner must depend more on assumptions.

4 Assumptions may cover either the enemy or friendly situations, or both. Enemy capabilities should not be treated as assumptions. It is appropriate for a commander to state as an assumption the success of other friendly operations over which he has no direct control, but which are essential to the success of his plan. It is not appropriate to state the success of one's own operations or phases thereof as an assumption since this success obviously must be presupposed.

(c) *Guidance Concerning Nuclear and Chemical Warfare.*

1 Nuclear and chemical warfare considerations in planning are extremely sensitive to the political environment. Guidance relative to the emphasis which should be given to nuclear and chemical aspects in the preparation of staff estimates should be provided by the commander as early in the planning process as possible.

2 Although the planning for possible use of these weapons is done by a specialized staff of qualified people, the supported command staff should understand the conditions under which nuclear and chemical weapons might be employed.

(d) *Political Considerations.*

1 In addition to the political aspects associated with the use of nuclear and chemical weapons, there are other political factors which can affect a military operation. Many political considerations in planning are essentially assumptions.

2 The commander must inform his staff of all such factors of which he has knowledge. Examples could be statements of the political aims of the operation or identification of specific military constraints being imposed because of political considerations.

(e) Tentative Courses of Action.

1 For the staff to organize their planning efforts and move in the proper direction, they need to know how the commander envisions the operation being conducted. By suggesting some tentative courses of action, the commander can provide that impetus. Tentative courses of action need not be complete; they may only state WHAT could be done (the types of operation) and WHERE they could be conducted (the locations or objectives). There are several options available to a commander as to the type of operation he will conduct.

2 As planning continues through the next two steps of the Concept Development Phase, the J-5 staff will be proposing courses of action and testing and refining them. The tentative courses of action suggested by the commander during his initial guidance should be included in the list of proposed courses of action, but may be modified, combined, or even deleted as more information becomes available. Eventually, each remaining course of action will be written in complete format, including not only the "WHAT" and "WHERE" described above, but also WHO will execute the operation, WHEN it will begin, and HOW, in very general terms, it will be accomplished.

(f) Planning Schedule.

1 Although practice will vary from staff to staff, it is usually desirable to issue a planning schedule with the planning guidance.

2 Normally drawn by the chief of staff or one of his immediate assistants, the planning schedule will set deadline dates or milestones for the completion of staff estimates, the submission of data inputs from subordinate and supporting commanders, and the drafting and distribution.

(g) Initial Staff Briefings.

1 Initial briefings on such subjects as terrain and hydrography of the area of operations, enemy capabilities, forces available, logistics support, and others, as determined by the command-

er, are vital to the staff early in the planning process. These early briefings focus and direct the staff agencies as they gather additional information and begin planning the operation.

2 These initial briefings are particularly important to the J-5, because the information will be used to formulate proposed courses of action. Information shared among the staff will also be helpful during the staff estimates step. In effect, an initial briefing is an early form of a staff estimate. In most cases, initial briefings will be prepared and presented by the appropriate staff agencies.

c. Step III—Preparation of Staff Estimates.

(1) Introduction.

(a) The staff estimates provide the foundation and substance from which the commander's estimate and the concept of operations are drawn.

(b) Not every planning sequence need be an extensive and lengthy effort. Conceivably, only a brief review of the assigned task, quick oral briefings, a decision, and the writing of a message-type operation order could complete the entire process.

(c) Generally, the higher the level of the command, the more extensive and complete will be the staff estimates and, thus, the planning process itself. Most joint commands are at the level where the planning process will necessarily be quite complete. Written estimates are not mandatory but, in most cases, they are highly desirable. Subordinate component commanders, on the other hand, who are supplied with a complete and specific OPLAN or order from the joint level, may be able to draw their own plans and orders with more abbreviated staff planning efforts.

(2) Relationship to Planning Guidance and Commander's Estimate.

(a) The interrelationships among the planning guidance, the staff estimates, and the commander's estimate require special comment.

(b) The initial briefings that are given while the commander is preparing and issuing his initial guidance, are, in effect, an early and usually incomplete statement of the staff estimates. Whether written or briefed in a conference, whether presented by the commander himself or by staff members, the identification of important terrain and hydrography features, enemy capabilities, logistics support, available forces and resources, deployment constraints, and other such factors, constitutes an important example of how the planning guidance and staff estimates blend together.

(c) One of the most important reasons for the initial briefings is to provide enough information to the J-5 staff so they can begin to formulate proposed courses of action. They cannot intelligently begin their work until they know the conditions under which the operation will take place.

(d) The purpose of each staff estimate is to evaluate the courses of action and indicate which of them could best be supported from the point of view of the staff agency making that estimate. The ultimate purpose of the staff estimate process is to provide the commander with the proper information that permits him to select the best course of action.

(e) Perhaps the best way to understand this admittedly complex relationship is to think of the staff as continuously estimating and reestimating the situation as the planning process occurs. The process is iterative, with better information and a more secure position being established with each iteration. Early staff estimates are frequently given as oral briefings to the rest of the staff. In the beginning, they emphasize information collection more than analysis. It is only in the later stages of the process that the staff estimates are expected to indicate which of the proposed courses of action can best be supported.

(f) Whether or not the staff estimates should be reduced to written form is a command decision. Written estimates are more precise and can easily be transmitted to subordinate staffs and other interested commands and agencies for their use and guidance. The level of the echelon and the size and complexity of the operation contribute to the determination of whether or not staff estimates will be in written form. Staff estimates can be written in final form after the commander's estimate is complete and the planning process is past the staff estimate step, provided such written estimates can still reach subordinate staffs in time to be of some value for coordination and for the development of annexes.

(3) *The Staff Estimates and Their Formats.* The formats for the personnel estimate, the intelligence estimate, the logistics estimate, and the communications-electronics estimate are descriptive in nature. Of these four staff estimate formats, only that for intelligence is prescribed by UNAAF for joint use. For the others, the format in FM 101-5 and comparable manuals of other services can be used.

d. Step IV—Commander's Estimate.

(1) The DOD Dictionary defines the commander's estimate of the situation as: "A logical process of reasoning by which a commander considers all

the circumstances affecting the military situation and arrives at a decision as to a course of action to be taken to accomplish his mission." The commander's estimate is one component of the concept development phase. It is a summation of all that has gone before and it produces the decision which leads to all that is to follow. When the commander has completed his estimate, he will have made his major decision and will have selected the course(s) of action which will be followed.

(2) UNAAF sets forth the following main paragraph headings for the commander's estimate:

- (a) Mission.
- (b) The situation and courses of action.
- (c) Analysis of opposing courses of action.
- (d) Comparison of own courses of action.
- (e) Decision.

(3) It can be seen that these five paragraphs are almost a precise match for the basic problem-solving process:

<i>Problem Solving</i>	<i>Commander's Estimate</i>
Recognition of problem	Mission
Collection of information	The situation
Development of possible solutions	Courses of action
Analysis of solution	Analysis and comparison
Selection of the best solution	Decision

(4) The staff may write the commander's estimate for approval or the commander may prepare it himself. In the majority of cases, the J-3/5 will do the actual work of preparing the commander's estimate after oral consultation and direction or he may prepare it in draft form for approval. By using a standard format, the location of particular types of information is facilitated, and the reasoning processes which were followed in analysis and comparison can be examined and evaluated. Unless there is sound reason for departure, it is the best practice to adhere to the prescribed commander's estimate format.

(5) In a tight tactical situation, the entire process involved in the development of the commander's estimate could take place in the commander's mind in the course of a few moments. The commander's thought process might include only the following questions:

- (a) What is my mission?
- (b) What are my alternative courses of action?
- (c) Which is best?

(6) In selecting courses of action for analysis in paragraphs 3 and 4 of the commander's estimate, three (or at most four) courses of action should be retained. If there is substantial ADP support, this number may be increased. Those selected should be the most promising of those that have been under consideration, and are actually different from each other.

(7) There are several checks the drafter of the commander's estimate can use to assist him in this task:

(a) *Suitability.* Will the course of action actually accomplish the mission or task if it is carried out successfully? In other words, is it aimed at the correct objectives?

(b) *Feasibility.* Do we have the required resources; e.g., the men, ships, planes, transportation assets, resupply, facilities, etc.? Can the resources be made available in the time frame contemplated?

(c) *Acceptability.* Even though the action will accomplish the mission and we have the necessary resources, is it worth the cost in terms of possible losses? Losses in time, materiel, and position must be included in addition to personnel losses.

(d) *Variety.* While there are military operations for which only one feasible course of action exists, in the great majority of joint operations, this is not the case. The point of the paragraphs 3 and 4 procedures is to analyze and compare meaningfully different courses of action. Alternative courses of action that are only superficially different, in effect, preempt the decision and remove most of the useful purpose from the conduct of the commander's estimate.

(e) *Completeness.* When, by means of the above checks, or other suitable procedures, courses of action are reduced to a manageable number; those retained should be checked to see if they are technically complete. Each of the retained courses of action should adequately answer the following:

- 1 What type of action is contemplated?
- 2 When is it to begin?
- 3 Where will it take place?
- 4 Who (what forces) will execute it?
- 5 How will it be accomplished?

There should be no inhibition concerning the clear explanation of the how in a course of action at this point. Keep in mind that these courses of action are for use within the commander's estimate process; they must be explicit enough in the how of the operation to enable sound judgments to be made.

Concern with usurping the initiative and prerogatives of subordinate commanders by including too much of the how is a matter to be considered when drawing up the concept of operations after the commander's decisions.

(8) The analysis of opposing courses of action connected in paragraph 3 of the estimate is not intended to select the best course of action or compare courses of action based on a particular factor. The analysis of each retained course of action when considered with each stated enemy capability should:

(a) Focus attention on each consideration in turn, thus insuring that none is omitted through oversight.

(b) Stimulate thought about the operation to get ideas and insights not otherwise thought of.

(c) Highlight those factors such as timing, simplicity, flexibility, weather on D-day, etc., which appear to be particularly important to this operation.

(d) Create a degree of familiarity with the tactical possibilities of the operation that would otherwise be difficult to achieve.

(9) The purpose of paragraph 4—Comparison of Own Courses of Action—of the estimate is to weigh the advantages and disadvantages of each retained course of action with respect to the governing factors developed in the analysis and provide the criteria for a decision. A worksheet constructed on a large sheet of paper may be helpful in making this comparison.

(a) After analyzing the advantages and disadvantages of a given course of action in light of one of the governing factors, a decision should be made as to whether or not that factor favors a specific course of action. If a factor favors more than one course of action, the courses should be listed in order of preference.

(b) When this process is complete, the results are tabulated.

(c) The worksheet is not normally a part of the written commander's estimate. A subparagraph of paragraph 4 is devoted to each retained course of action in which are indicated the governing factors considered together with a brief summary of the advantages and disadvantages of that course of action in regard to that particular governing factor. Paragraph 4 of the written commander's estimate is a brief, typed summary of the points developed on the worksheet.

(d) The final subparagraph is a statement of conclusion: "Course of action is favored because . . ." and the reasons are set forth.

(10) Decision:

(a) Regardless of whether or not the commander's estimate to this point has been written by the J-3/5 or by the commander himself, the decision is the commander's alone.

(b) In normal staff practice, the J-3/5 will present a written commander's estimate, with the selected course of action at the end of paragraph 4 (as indicated above), and a recommendation stated in paragraph 5. If acceptable to the commander, the recommendation becomes the decision.

e. Step V—Concept of Operations.

(1) The concept of operations is an expression of the overall picture of the operation as the commander sees it. It is based on the commander's estimate of the situation and is an expansion of the selected course(s) of action. It serves to:

(a) Clarify the intent of the commander in regard to deployment, employment, and support of allocated forces.

(b) Identify major objectives and target dates for their attainment.

(2) The concept of operations, prepared in this step, ultimately will be used in paragraph 3 (the execution paragraph) of the basic plan and is the keystone around which detailed force structuring, tactical planning, deployment planning, resupply planning, transportation planning, civil engineering support planning, and other elements of the plan are designed.

(3) The concept of operations should be developed in sufficient detail to convey a clear and complete understanding of how the overall operation will be conducted from beginning to end. Care must be taken not to include too much of the how of the operation in the concept of operations.

(4) Test and Refinement:

(a) Throughout the preparation of the concept of operations, all factors which can have a significant effect on the accomplishment of the mission must be considered and their impact determined. Should shortfalls in forces or resources (in terms of type, quantity, or timing) be identified, such shortfalls must be resolved or otherwise accommodated.

(b) When the three main elements of the concept of operations (e.g., the concepts of deployment, employment, and support) have been developed, they should be tested as a package for feasibility.

(c) The concept of operations must be refined to accommodate all unresolved shortfalls or the risk associated with such shortfalls must be accepted. (NOTE: The completion of an OPLAN will not be delayed pending the resolution of a shortfall or limiting factor.)

(5) Transmitting the Concept of Operations:

(a) There is no prescribed format for the documentation of the concept of operations; local practice should be followed. Sometimes an outline plan, letter of instruction, or a planning directive is used to transmit the concept of operations or conference techniques are employed.

(b) Usually, the subordinate commanders and interested supporting commanders and agencies are represented in concept development conferences called by the supported commander and, thereby, participate in the development of the concept of operations. Normally, following such conferences minutes are formalized and distributed to the conferees under a covering letter of transmittal which contains the comments and/or approval of the supported commander.

(c) When an outline plan is prepared, the data developed in this step, along with that which has been gathered in previous steps, is reflected. The outline plan serves as a guidance document which can be expanded into an OPLAN or CONPLAN, as appropriate, and contains:

1 A clear and concise mission statement.

2 A statement of assumptions that are necessary to continue planning.

3 A general statement about the forces to be employed, what they will do, where it is to be done, and the phasing of the operation.

4 A description of the employment of forces, with time-phasing information, if needed, and the roles of land, air, and naval forces, including those amphibious, unconventional warfare (UW), and counterinsurgency operations critical to the overall mission.

5 A summary of the deployment of forces necessary to accomplish the mission, including major augmentation from other commands.

6 A summary of supporting operations to be conducted (conventional, nuclear, UW, et al.) and a description of their objectives.

7 A description of the concept of support for deploying and employing forces; a summary of factors that impact on the logistics effort, including pre-positioned war reserve stocks (PWRS) availability, stock level objectives, levels of con-

sumption and expected deviations from normal rates; identification of mutual support requirements from allied and other friendly nations, and assignment of Inter-Service support agreements.

8 A summary of command relationships, including the creation of subordinate commands, and the command lines to subordinate forces.

9 In separately numbered paragraphs, a list of assigned tasks for subordinate elements, including not only the military tasks that contribute to the accomplishment of the overall command mission, but also administrative tasks, such as the preparation of supporting plans and the coordination of Inter-Service support agreements.

(6) Concept Review. Upon completion of the concept of operations, the commander forwards it to the Joint Chiefs of Staff for concept review. This review is applicable to new OPLANs or existing OPLANs in which the concept has changed. The purpose of the review is to determine whether the scope and concept of operations are sufficient to accomplish the task assigned, and to assess the validity of the assumptions and compliance with JCS tasking and guidance. JCS approval of the concept will be for "further planning only."

5-13. Plan Development Phase (PDP)

Plan development is an expansion of the direction and guidance provided by the supported commander, together with that which is contained in service documents and JCS publications. In its broadest application, the PDP consists of the development of detailed force lists along with required closure times of forces to be deployed to the area of operations, the determination of resupply, base development and transportation requirements, the identification and resolution of force and resource shortfalls, and the documentation of the plan in prescribed format. The concept of operations (i.e., the concepts of deployment, employment, and support) as derived by the supported commander in the concept development phase drives plan development. The plan development phase begins when the supported commander provides to the appropriate subordinate commanders and supporting commanders and agencies, his concept of operations and ends when the plan has been documented in the format and detail required by appropriate sections of JOPS, Volume I, and the Joint Reporting Structure (JCS Pub. 6).

(Note: Many of the planning tasks identified below can be started by subordinate and supporting commanders in advance of receipt of the finalized concept of operations, if the preliminary guidance provided by the supported commander is adequate to serve as a basis. The supported commander may use an outline plan to transmit his concept of operations, deployment, support and planning guidance, to all interested com-

mands and agencies. This is followed by a plan development conference which is attended by representatives from the supported command components, appropriate supporting commanders, and the TOAs.)

a. If a CONPLAN (i.e., an OPLAN in abbreviated format) is desired, plan development consists of the documentation of the plan in the format and detail prescribed in JOPS, volume I, chapter VI. (Normally, detailed annexes, TPFDD, base development data, and supporting plans are not required.)

b. If an OPLAN (i.e., an OPLAN in complete format) is desired, plan development is accomplished in detail using notional or type unit forces, programed resource assets, planning points of origin, planning POEs, and planning ports of debarkation (POD). The basic plan and all annexes are documented in the format and detail prescribed in JOPS, volume I. TPFDD and base development data are documented in the format prescribed in JCS Pub. 6.

c. In the exceptional or crisis management situation when no existing plan can be adapted to fit the requirement, the emergency preparation of an OPORD by the supported commander may be necessary. Accelerated planning procedures are employed in such circumstances. When the situation requires time-sensitive response action, crisis management and reporting procedures of the Crisis Action System (CAS) may be invoked.

d. Although the PDP will be explained in sequential steps (since such a procedure is necessary to clear understanding), it should be kept in mind that, in actual practice, plan development will not take place in clearly defined individual steps. Each of the steps portrayed should be initiated when the data available is adequate to serve as a basis. The results of preliminary work on one step may impact on, or be employed as, a factor in a previous step which, in turn, produces results which impact on yet another step. Because of the complexity of plan development iterations and the interdependence of derived data, the PDP of joint planning is heavily dependent on automation and simulation. Keeping these words of caution in mind, the sequential steps of the complete PDP are listed in figure 5-4 and graphically portrayed in figure 5-5. Figure 5-5 (fold-in page) is located at the end of this manual.

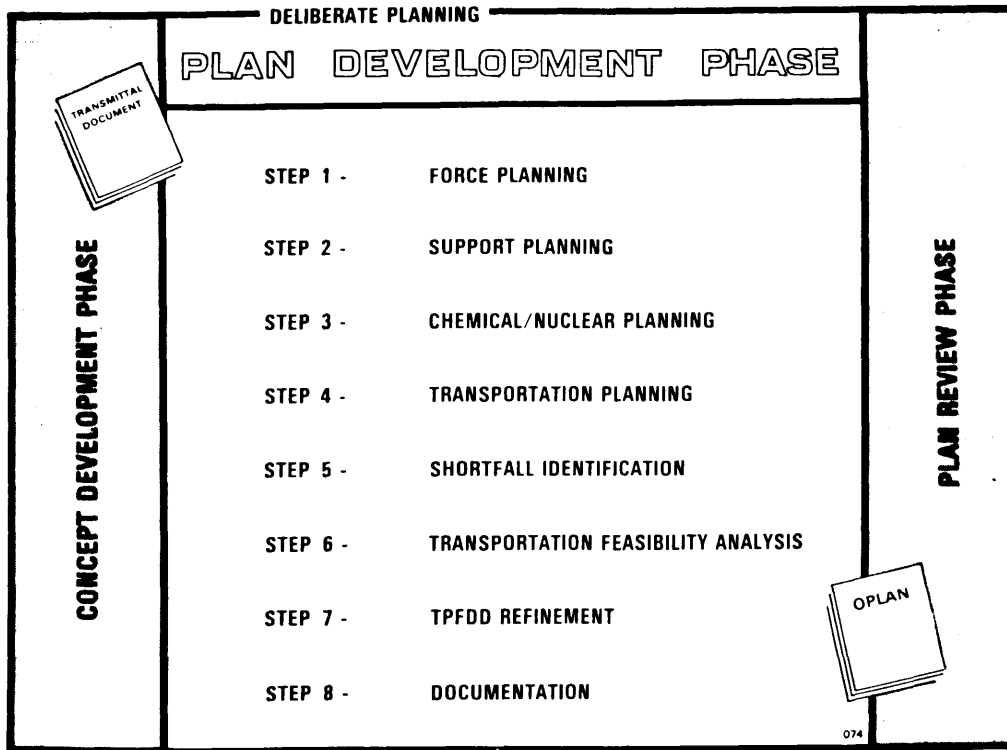

Figure 5-4. Steps in the plan development phase.

e. A general description of each of the steps follows:

(1) The first step in plan development is force planning. The purpose of force planning is to identify and time-phase all the forces needed to support the CINC's concept of operation. The force lists developed during this step include not only the major combat forces, but also combat support and combat service support forces. While force planning is ultimately the responsibility of the supported commander, each Service component develops its own force list, since the Service is the source of information needed to build the force list. The force lists are assembled using a JOBS ADP application program called the Force Requirements Generator (FRG). The components can use real-world forces to build the force list, if they are already known, but the Services cannot always identify specific units too far in advance. In that case type units, described in the TUCHA file, are used for planning. While the Service components are given the task of completing their force lists, the process actually requires the planners to go through a series of intermediate coordination steps before the final product is submitted.

(a) Each of the Service components constructs, time phases, and submits a major force list (MFL) to the supported commander.

(b) The supported command staff combines the MFLs submitted by the components and evaluates the resulting consolidated major force list (CMFL) to determine whether it is adequate to perform the mission. If the supported commander concurs with the joint force list, the components will then expand their major force lists by adding detail down to unit level (battalions, squadrons, detachments, teams, etc.). Each component will also determine the requirements for additional combat forces, as well as combat support and combat service support forces and will add them all to its MFL to make the component total force list (TFL).

(c) Finally, the planners must add all the information needed to deploy their Services' forces flow from where they are to where they are needed. Their move must be time-phased to make the most efficient use of limited transportation assets and still get the forces to their destination in sufficient time to support the CINC's operation. Deployment data are entered into the TPFDD for each of the units in the force list. Typical information includes the mode of transportation, the port of embarkation (POE), the port of debarkation (POD), and the latest arrival date (LAD) on which the force can be delivered at the POD.

(d) After the total force list has been assembled, a Force Requirement Number (FRN) is assigned to each separate force entry in the force

list. The FRN is useful because it allows the planner to track a unit wherever it is moved within the TPFDD. The planner then uses another computer program module in the FRG to produce a printout showing the forces and the deployment information. This Time-Phased Force and Deployment List (TPFDL) lists all units sequenced by LAD and POD. The force planning step ends when a TPFDL is produced that supports the CINC's concept of operation.

(e) Force planning as discussed in the above steps focused on the use of the JOPS ADP program called the FRG. Due to the recent release of the Force Module Subsystem (FMS), the planner now has the option of building the force structure using force modules. This system is designed to increase the speed and flexibility of joint operation planning by grouping key combat units with their associated support and sustainment.

(2) The second step in the plan development phase is support planning. During this step component commanders continue to work with their Services to ensure that their forces will be sustained in combat. Support requirements include supplies, equipment, materiel, and replacement personnel for the forces, as well as civil engineering materials and medical materials. Support planning begins when the number and type of units to be employed in the operation have been identified. Support planning is completed when all significant supply, equipment, and personnel requirements have been specifically determined and their movement characteristics have been entered into the TPFDD. Support planning can be accomplished in one of two ways. First, the component planners compute their own support requirements and forward their component TPFDD file (containing force and support data) to the supported command for consolidation. This is the preferred method since logistic support is a Service responsibility. In the second method the component commanders provide their Service force list and planning factors to the supported command. Joint planners then consolidate the components' force lists and compute total support requirements. In force planning, we developed the transportation requirements for units. In support planning, transportation requirements for all the things necessary to support these units are determined and their movement characteristics entered into the TPFDD.

(3) The third step is chemical/nuclear planning. This step consists of chemical/biological (CB) planning and nuclear planning. The CB planning process requires the component commanders submit their chemical requirements to the supported commander who consolidates these submis-

sions into a single time-phased list and a separate TPFDD is prepared. During the nuclear planning process, the supported commander will again consolidate nuclear requirements and these requirements time-phased will be passed to the MAC for incorporation in the appropriate CINCMAC OPLAN.

(4) The next step is transportation planning. This step in the Plan Development Phase is the first of a three-step iteration directed towards solving the complex strategic movement problem. The goal in transportation planning is to produce a transportation-feasible OPLAN. Planners at the supported command must determine if the movements requirements that have been generated by component planners during the force planning and support planning steps can be deployed (using the transportation assets that have been made available for planning) to the area of operations in time to support the CINC's concept of operations. If the force cannot be moved in a timely manner, planners must, in the next two steps, identify and resolve the problems that restrict the move, and evaluate what the changes will do to the overall plan concept. Using a major program in the JOPS ADP system called the Transportation Feasibility Estimator (TFE), planners at the supported command run a computer simulation of both the strategic air and sea movements of the forces and their support requirements from POE to POD. Transportation assets that have been identified by the JSCP for use in the OPLAN are used by the TFE to "move" the force. Reports from the computer simulation are produced to show the feasible arrival date (FAD) of each unit and supply shipment. If all the units and supply shipments arrive on time, the plan is considered to be transportation feasible. When the FAD of any unit or supply shipment is computed to be later than the latest arrival date (LAD) designated by planners, a shortfall exists in the plan which must be resolved. This leads to the next two steps.

(5) The fifth step in plan development is shortfall identification. Identifying and resolving shortfalls is continual throughout the planning process. This step, however, focuses on the identification and resolution of those transportation shortfalls that are highlighted by the TFE deployment simulation. Adjustments made by the planner to correct shortfalls are restricted to those that will not affect the CINC's concept of operation or his concept of support. Planners should also identify unresolved shortfalls that must be considered for corrective action by higher-level decisionmakers, or those that must be discussed in conference with representatives from other commands or agencies

for resolution by compromise or mutual agreement. It is important to note that the commander must approve any change that would affect the concept of operation or concept of support. Listed below are a number of actions that can be taken to resolve shortfalls. A combination of options may be necessary.

- (a) Adjust unit or cargo priority.
- (b) Adjust POE, POD, routing, or timing.
- (c) Change lift mode.
- (d) Pre-position forces/resources.
- (e) Build or upgrade ports and airports.
- (f) Seek additional assets.
- (g) Redefine concept of operations.

The plan should be submitted to JCS with unresolved shortfalls if the other options cannot resolve them, or if the use of the options would result in an unsatisfactory solution to the problem.

(6) The next step is the transportation feasibility analysis. During this step in the Plan Development Phase, the planners must analyze the closure match and determine if the plan is grossly transportation feasible. If it is not, more adjustments must be made, the TFE run again (Step 4) and shortfalls identified and resolved (Step 5). The commander may convene a Plan Development Conference and invite representatives from throughout the joint deployment community. These planners from the various commands and agencies should meet to evaluate unresolved shortfalls, to select the means to overcome limiting factors, and to determine the consequences of such actions. Shortfalls that cannot be resolved will be documented and submitted to JCS for review and appropriate action.

(7) The seventh step in plan development is TPFDD refinement. During this step the TPFDD is verified to ensure that actual units are correct and that unsourced requirements have actual units assigned if available. The OPLAN TPFDD is submitted to JDA in accordance with the annual JSCP Schedule. Gross feasibility estimates are conducted prior to this submission. They are concurrently sent to JCS for intermediate review, an informal review of the plan and its TPFDD to prepare JCS representatives for the JDA-sponsored TPFDD refinement conferences. Copies are also made available through the JDA to the supporting commands, Transportation Operating Agencies (TOAs), and other agencies participating in the refinement process. The JDA host two TPFDD refinement conferences for the supported commander.

(a) Phase I Conference. The purpose of the first conference is to resolve any force, personnel, and resupply shortfalls and to update the TPFDD with actual force data for any remaining unsourced requirements. Conference attendees will include, as a minimum, representatives of the supported commander, the JCS, the Services, TOAs, other supporting commands, JDA and other defense agencies that are affected by the plan.

(b) Phase II Conference. JDA will convene a second TPFDD refinement conference after the TOAs have had time to analyze the data from the first conference and prepare and coordinate movement tables. The second conference is to discuss the combined transportation requirements and shortfalls with the supported commander, incorporate movement tables into the data base, and get the CINC's approval of the TPFDD closure profile. Immediately following the refinement process, the information contained in the TPFDD is transferred to the Joint Deployment System (JDS), where it will be stored and maintained for future use.

(8) Plan documentation is the final step in the Plan Development Phase. The objectives of this step are to prepare the plan in JOPS format, including the basic plan, all required annexes and appendices, and other administrative documents required for submission and distribution. The fully documented plan, together with its refined TPFDD, is an operation plan in complete format. Administrative guidance and formats for the OPLAN are contained in JOPS, Volumes I and II. The majority of the supporting commands and agencies that receive copies of the completed OPLAN have access to the plan TPFDD through their own WWMCCS computer terminal. If, however, the plan is sent to organizations that do not have ADP capabilities, selected information can be extracted from the TPFDD and included in the written plan for their use. These two computer products are called the Time-Phased Force and Deployment List (TPFDL) and the Time-Phased Transportation Requirements List (TPTRL).

(a) The TPFDL will be included as Appendix 1, Annex A, of the OPLAN.

(b) The TPTRL will be included as Tab B to Appendix 4, Annex D, of the OPLAN.

5-14. Plan Review Phase

a. During this phase, the JCS perform a final review of operation plans submitted by unified and specified commanders. It is a formal review of the entire operation plan, including TPFDD, if applicable (see figure 5-6).

DELIBERATE PLANNING: PLAN REVIEW AND SUPPORTING PLANS

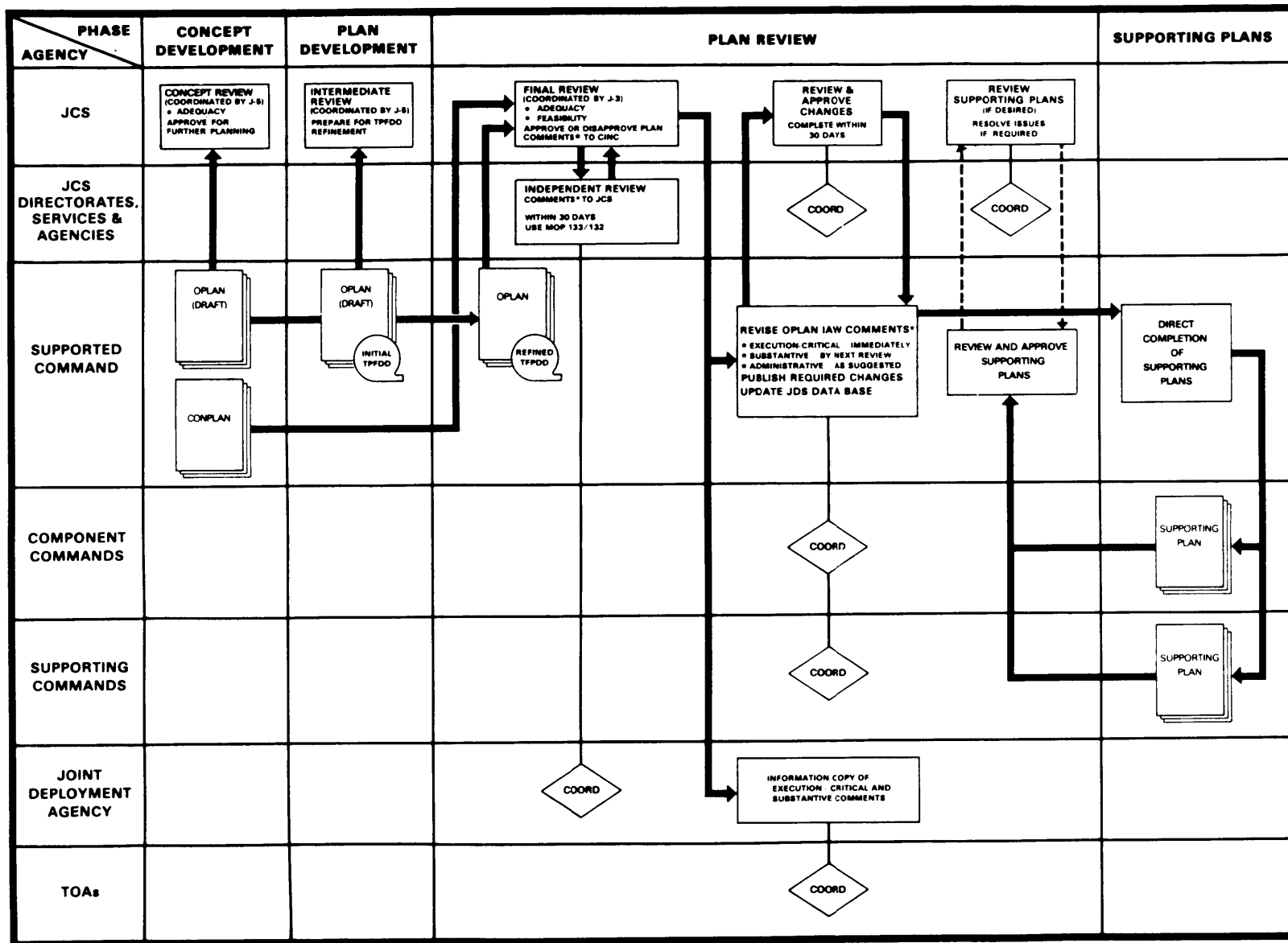

Figure 5-6. Plan review and supporting plans phases.

b. The JCS review and approve operation plans required by the JSCP and other JCS directives. According to JOPS, Volume I, operation plans are:

(1) Plans of unified and specified commanders, including OPLANs, CONPLANs, emergency evacuation plans, continuity of operation plans, and disaster relief plans.

(2) Bilateral military plans and planning studies.

(3) Military plans of international treaty organizations.

(4) Plans for defense, other than aerospace defense, of the continental United States and military support of civil defense.

(5) Unconventional Warfare (UW) plans.

c. A plan is normally reviewed according to the following plan review criteria.

(1) The review for adequacy determines whether the scope and concept of operation are sufficient to accomplish the assigned task. It assesses compliance with JCS tasking and the validity of assumptions.

(2) The review for feasibility determines whether assigned tasks could be accomplished using available resources. Appropriateness, availability, and planned use of available resources are also considered.

d. Plans submitted to the JCS for review are referred to the OJCS directorate having primary staff responsibility (normally the J-3), which conducts and coordinates the final plan review. Other directorates and agencies participate as required. The Services also take part, including doing a legal review for compliance with domestic and international law.

e. Reviews by responsible agencies are conducted independently; their comments are forwarded to JCS within 30 days of referral. Comments are categorized as execution-critical, substantive, or administrative.

(1) Execution-Critical comments are directive. As significant comments, their immediate incorporation into the plan is essential.

(2) Substantive comments are also directive. They are important comments which must be incorporated into the plan by the next annual JCS review.

(3) Administrative comments are given to the supported commander as suggestions.

f. Reviews are processed under the provisions of JCS MOP 132 or JCS MOP 133. MOP 132 is used for papers that should be personally addressed by the Joint Chiefs of Staff or their Operations Deputies. MOP 133 is used to issue instructions in the name of the Joint Chiefs of Staff and should be

used when practical to provide a timely response to the supported commander.

g. After the review, the supported commander is informed that his plan is

(1) Approved, subject to the incorporation of execution-critical comments. JCS plan approval means the plan is effective for execution, when directed.

(2) Disapproved, for reasons stated.

(3) Approved for continued planning. Plans with unresolved shortfalls cannot be given unqualified approval. The approval message will include guidance for developing supporting plans and actions to rectify unresolved shortfalls.

h. The supported commander prepares changes to his operation plan to incorporate execution-critical comments (within 30 days) and substantive comments (before the next annual review). Changes normally are submitted to JCS for approval, and the review of the changes follows the procedures for plan review.

i. Supporting plans prepared by subordinate or supporting commanders or other agencies are normally reviewed and approved by the supported commander. Review procedures at those levels are contained in command-unique instructions.

5-15. Supporting Plans Phase

a. During this phase of the deliberate planning process, the supported commander directs the preparation and submission of supporting plans (see figure 5-6). Supporting plans deal with a number of functions, including mobilization, deployment, and employment. Plans may be developed by component commands, joint task force commands, supporting unified or specified commands, TOAs, or other agencies. These commands may, in turn, task their subordinates to prepare additional supporting plans. In all, a family of plans is produced to accomplish the overall mission of the supported command.

b. A supporting plan that directly supports an OPLAN normally carries the plan identification number (PID) of the supported command's plan, and the supporting plan summary identifies the OPLAN which it supports. In some cases, however, a command is required to perform essentially the same actions to support two or more supported commands' plans. Instead of preparing multiple supporting plans (containing essentially repetitive material), the command prepares a single plan carrying its own PID, and the plan summary contains a list of the OPLANs it supports.

c. Employment plans are normally the responsibility of the commander who will direct the forces when the OPLAN is executed. In many cases, how-

ever, the politico-military situation cannot be clearly forecast, so employment planning is delayed until circumstances require it.

d. Supporting plans must be submitted to the supported commander within 60 days after the approval of the plan they support. Review of supporting plans is the responsibility of the command they support. JCS, however, may be asked to resolve issues that arise during the review of sup-

porting plans, and they can review any supporting plan, if they wish.

5-16. Time Sensitive Planning

a. *Purpose.* This section describes the Crisis Action System (CAS) and shows how it is used to support time-sensitive planning. The primary actions expected of responsible commands and agencies are also described (see figure 5-7).

TIME-SENSITIVE PLANNING		
THE CRISIS ACTION SYSTEM (CAS)		
MILITARY COMMAND ACTIONS	NCA/JCS ACTIONS	RESULTING DIRECTIVE
<p>PHASE I SITUATION DEVELOPMENT Worldwide events are monitored to detect situations that could affect U.S. policy or interests. A significant incident is recognized and reported to an appropriate government agency. The CINC sends a commander's assessment of the situation to JCS/NCA.</p>	<p>PHASE II CRISIS ASSESSMENT JCS/NCA consider all available information to determine if a crisis exists. NCA identifies possible options (diplomatic, economic, military, etc.). JCS considers military courses of action and may direct higher military alert condition or deployability posture.</p>	<p>JCS WARNING ORDER The Warning Order designates supported/supporting commanders and command relationships. It describes mission and objectives, allocates forces and lift assets, and suggests courses of action. It calls for the Commander's Estimate and JDA deployment estimates. The Warning Order initiates Phase III.</p>
<p>PHASE III COURSE OF ACTION DEVELOPMENT The CINC develops and evaluates courses of action, using information from deployment data bases and input from components and supporting commanders. He forwards Commander's Estimate to JCS with recommended course(s) of action and support requirements. JDA/TOAs prepare deployment estimates. JDC updates deployment data base.</p>	<p>PHASE IV COURSE OF ACTION SELECTION JCS reviews Commander's Estimate and deployment estimates, then presents courses of action, in order of priority, to NCA for selection. In rapidly developing situations, this phase may occur without formal development of courses of action (Phase III).</p>	<p>JCS ALERT ORDER The Alert Order reflects the NCA decision. It defines the mission, updates the current situation, issues strategic guidance, and sets the anticipated date of execution. If events prohibited issuing a Warning Order, the Alert Order contains necessary planning guidance. The Alert Order initiates Phase V.</p>
<p>PHASE V EXECUTION PLANNING CINC completes and refines planning done in Phase III. He develops, publishes, and distributes OPORD, including actual force list, operations instructions, and logistic and administrative guidance. Supporting OPORDs are developed. Units stay prepared for deployment until ordered to execute or until crisis is resolved by non-military means.</p>	<p>PHASE VI EXECUTION The OPORD and supporting OPORDs are executed upon receipt of Execute Order. Deployment data base and movement schedules are kept current. Movement and status of forces are monitored and reported. The phase continues until the crisis is resolved or until forces are withdrawn.</p>	<p>JCS EXECUTE ORDER The Execute Order reflects the decision of the NCA to use the military option to resolve the crisis. It contains the most current information available, provides the latest guidance, and establishes an execution time.</p>

074

Figure 5-7. Time sensitive planning.

b. *Background.*

(1) A crisis usually develops with little or no warning, and the President and his advisors must make quick decisions about a suitable course of action for the nation to take in response to it. There are many options that are likely to be presented for consideration. The President can choose to do nothing, or can elect to use diplomatic, economic, or military means to solve the problem.

(2) After a series of crises in the early 1970s, the National Command Authority (NCA) became concerned that the military organization for responding to crisis situations was ineffective, and that various parts of the Joint Reporting Structure (JRS) were not providing adequate and timely information to support the decisionmaking process. A system for time-sensitive military planning was developed and is described in the Joint Operation

Planning System (JOPS), Volume IV, Crisis Action System (CAS).

(3) The focal point for military crisis management is the National Military Command Center (NMCC) operated by the JCS J-3 in Washington. From the NMCC, crisis action teams coordinate with the NCA, the military commands, and other agencies while dealing with a crisis.

c. *Description.*

(1) CAS provides a framework for the rapid exchange of information. It arranges for recommending and evaluating feasible courses of action. It uses commonly accepted planning procedures and formats wherever possible, but recognizes the need for varying degrees of detail as a function of time available for planning.

(2) Since each crisis is unique, a rigid set of rules to respond to crises would be unacceptable.

Instead, CAS is a flexible system that responds to the demands of a dynamic situation. Like any system, CAS is the combination of people, procedures, and hardware which enable the work to be done. The CAS objective is the timely development of a military option to present to the NCA for consideration and use in response to a national crisis.

(3) The time-sensitive planning process takes the participants through a logical sequence of phases that leads from the initial recognition of the problem to the development and execution of an operation order. The six phases of CAS are shown in figure 5-7. The phases alternate between action being taken at the military command level and action taken at the NCA level. Several points are identified in the sequence where decisions must be made either to continue planning or to revert to an earlier phase in the process. Formal JCS orders are issued after major NCA decision milestones. Extremely critical situations could compress the actions taken in Phases H through V.

(a) *Phase I—Situation Development.* In this phase, any event that could be considered a potential crisis is recognized, reported, and assessed to determine if it could affect national interests. The development occurs in several steps.

1 *Situation monitoring.* Monitoring events worldwide with all available agencies and sources to detect situations that could conceivably have a bearing on US policy or interests.

2 *Event.* Something out of the ordinary which might have future implications for the US Government.

3 *Problem recognition.* A US Government official recognizes an event as being a problem or a potential problem and reports the matter to an appropriate Government agency.

4 *Reports.* When a problem is recognized, a report (message, telephone, etc.) is submitted to the appropriate command center. Two formal reports which would initiate the action are Critical Intelligence Communication (CRITIC) and Event/Incident Report of Possible National Interest (OPREP 3).

5 *Commander's assessment.* Based on the preliminary information available, the unified commander sends to JCS an OPREP 3 PINNACLE report on the situation and states what forces he has readily available, the time frame for their earliest commitment, and any major limiting factors to their employment.

6 *JCS/NCA situation review and assessment.* Decisionmakers at the national level will

assess the event and the commander's report and determine whether it is a problem of national concern. If they determine that it is not, normal situation monitoring continues. If, however, they decide that the event is a problem of national concern, they proceed to Phase II of the CAS.

(b) *Phase II—Crisis Assessment.* During this phase, reporting is increased, and the problem is carefully analyzed to determine whether it meets the definition of a crisis.

1 Since the event has been categorized as a problem of national concern, surveillance and reporting are greatly increased to provide all the information possible to the decisionmakers. During this phase, they must decide whether the problem should be categorized as a crisis. If they decide it is not yet a crisis, increased reporting will continue and information will be gathered for further study. If a crisis is declared, a JCS Warning Order is prepared for release.

2 During this phase, the JCS may issue a deployment preparation order or a deployment order. They can also order an alert condition or a specified deployability posture. These actions are designed to reduce response time, should the situation require rapid response by the forces. These orders could be issued any time during the crisis, or could be issued in conjunction with the JCS Warning or Alert Order.

3 The President might decide to order immediate military action, and the CAS would pass directly to a later phase.

4 While these actions are taking place, special teams are assembled to deal with the crisis. The teams vary in size and composition, just as they vary in name and purpose. They may be called Battle Staffs, Crisis Action Teams, Deployment Action Teams, Operations Action Groups, or Operations Planners Groups. They may include representatives from any or all staff agencies. Generally, emergency response teams can be formed at all levels, from individual units and commands up to the NMCC.

(c) *Phase III—Course of Action Development.*

1 In this phase, the planning process begins in earnest. The JCS Warning Order initiates the development of courses of action, the formation of force lists and support requirements, and the recommendation to the NCA of the best course of action. Component commands, supporting commands, TOAs, and the JDA work with the commander to support the planning effort.

2 The JCS Warning Order, in addition to initiating this phase of planning, establishes command arrangements for forces participating in the operation, suggests some potential courses of action for the commander to consider, and updates the information available from the JCS perspective.

3 After the commander has received tasking, he further defines the mission and, with the help of his staff and using procedures that are similar to those in the deliberate planning process, considers alternative courses of action. Whenever a crisis occurs, existing operation plans should be reviewed to see if one of them is suitable for use. An OPLAN should be modified for use if possible. If a CONPLAN can be used, it should be expanded to include forces and support requirements. But, as is often the case, if no plan exists, an OPORD will have to be developed from scratch.

4 Time is an extremely valuable commodity during this phase, so planners must transfer information among units as rapidly as possible. WIN is used for quick and accurate data transfer. OPREP-1 message formats have been developed as a backup system. CAS planning is done using actual forces instead of type forces. Force modules will be used for planning to the extent possible.

5 The commander consolidates all available information to submit his Commander's Estimate to the JCS, who will evaluate it in light of information gathered from other sources. This Commander's Estimate contains much the same information as the document of the same name prepared during deliberate planning, but it is more abbreviated. The CINC only recommends a course of action during CAS, instead of selecting the best course of action as he does during deliberate planning.

6 The Commander's Estimate is also sent to the TOAs and to the JDA who will use the information to finalize deployment estimates and update the JDS deployment data base. Their work is done concurrently with the planning at the supported command level.

7 Phase III of CAS is similar in function to the Concept Development Phase of the deliberate planning process.

(d) Phase IV—Course of Action-Selection. The Joint Chiefs of Staff review the Commander's Estimate, the courses of action, and the CINC's recommendation. With the deployment estimates developed by the JDA (in conjunction with the TOAs) and the courses of action submitted by the commander, the JCS have enough information to present the recommendation to the Secretary of

Defense and the President. As previously mentioned, other nonmilitary options may have been prepared by the National Security Council, the Department of State, or the Central Intelligence Agency for the President's consideration. If the President feels that the military option may be used, he will select a course of action or, more typically, approve the recommended course of action. His decision is announced in a JCS Alert Order which is prepared for release.

(e) Phase V—Execution Planning.

1 This phase begins with the receipt of the JCS Alert Order. Planning is done at several levels concurrently, based on information contained in the Alert Order, and is aimed at the completion of the operation order (OPORD), the final product of the time-sensitive planning process.

2 The Alert Order describes the military course of action selected by the NCA, sets tentative or actual target dates for the operation, and provides the necessary guidance for the preparation of the OPORD.

3 Planners at the supported command, assisted by the deployment community, complete the force list. They also detail resupply and replacement requirements as much as possible. The JDS Deployment Data Base is the authoritative, up-to-date source of the force and resupply information. The data base can be queried by the entire deployment community using the WWMCCS Inter-computer Network (WIN), or information can be obtained from the JDA by message or telephone. In a crisis, no means of communication can be overlooked to get the critical job of planning accomplished.

4 An OPORD is prepared in OPREP-1 message format. The narrative portion contains the task organization, situation description, mission, concept of operations, anticipated time of execution, rules of engagement, command relationships, logistics information, and other administrative guidance.

5 Supporting commands, component commands, and TOAs develop supporting OPORDs, as required. The JDA helps to update the force list and to coordinate the development of the flow plans and schedules prepared by the TOAs.

6 The OPORD, when it is complete, does not require approval by the JCS. If the OPORD is contrary to the guidance contained in the Alert Order, the JCS will inform the commander of the difference. If circumstances change, requiring an

adjustment in the OPORD, the JCS will also keep the commander informed.

7 Phase V of CAS is similar in function to the Plan Development Phase of the deliberate planning process.

(f) Phase VI—Execution.

1 When the President makes a decision to exercise his military option, the Secretary of Defense authorizes and directs the Joint Chiefs of Staff to issue a JCS Execute Order instructing the commander to carry out the provisions of the OPORD. Supporting commands are also instructed in the Execute Order to implement their supporting OPORDs.

2 JDA monitors the status of deploying military forces and selected critical material items, and keeps the information current for reports to JCS. During the deployment, the supported commander can request changes in movement flow based on a change in the operational situation. JDA will coordinate the request and make adjustments to the flow schedule. JDA is also required to accommodate the return of casualties and noncombatant evacuees during the deployment.

3 The execution phase continues until the operation is complete.

5-17. Summary

a. In this chapter we have looked at the National Military Planning System and discussed the roles of the NSC, the Secretary of Defense and Secretaries of the services in the defense PPBS. The role of the JCS in national military strategy formulation was analyzed with emphasis on the major planning documents prepared by the JCS. A detailed examination of the JOPS was undertaken along with a discussion of the role of JOPS within the joint planning cycle. From an examination of the purpose and procedures within each phase of the joint planning cycle, it should be apparent that the logistics planner is deeply involved in all phases and plays a predominant role in most.

b. The fact that contingency or OPLANs are prepared for many eventualities does not insure that a workable plan will be on hand for actual emergencies. Long-range plans must be based on certain assumptions; however, plans that are executed must be based on realities. For this reason we have a CAS in which new plans are developed or existing plans modified prior to execution.

c. The important contribution of ADP equipment, coupled with standardized software and format, to the ability of military planners to produce/modify realistic plans should be apparent. The interrelationships and interdependencies of

the many factors involved in supporting military forces in theaters of operations are of such complexity that determination of the feasibility of a plan by normal methods becomes virtually impossible. The feasibility testing aspects of JOPS, however, allows a determination throughout the planning cycle of the ability of US forces to actually implement the plan.

d. The joint planning process is a coordinated staff procedure used by a commander to determine the best method of accomplishing assigned tasks and to direct the action necessary to accomplish his mission. Stated slightly differently, it's a logical procedure used by a joint force commander to reach a sound operational decision and to prepare the plan or order to implement the decision. The joint planning process is initiated when a task, either directed or dedicated, is imposed on the joint command. Each plan is subject to annual review by the JCS and continuous monitoring by the supported unified commander, JCS, and the military services to determine and accomplish changes resulting from changes in the world situation, US policy, availability of resources, materiel changes resulting from technological dynamics, and other related conditions.

e. All contingency plans are prepared in line with the JOPS, as required by JCS direction. This system provides standard guidance in procedures such as a simple format for an OPLAN, identification of what data must be included, who should get copies of the plan, and how various headquarters interact during the planning process. The joint planning process is a lengthy procedure which follows a specific timetable for completion of the various phases.

f. The JOPS includes guidance on such matters as how to plan the intelligence aspects of a joint military operation, standard logistics guidance, and civil affairs responsibilities. Under the JOPS, the inclusion of specific responsibilities for possible tasking to service components of a unified command offers more definite guidance for accurate logistics planning and possible expansion of areas such as common support. The JCS are charged with the responsibility of ascertaining the logistics support available to execute general war and contingency plans of the commanders of the unified and specified commands. Perhaps the best word to describe the functions of the JCS in its role with the JOPS is "coordination." It is their duty to bring forward the problems of the unified and specified commands and assist and represent them in the solution of the problems and to foster joint

planning. Among its other responsibilities related to the joint planning process, the JCS:

(1) Recommend to the Secretary of Defense the establishment and force structure of unified and specified commands in strategic areas. They determine the headquarters support, such as facilities, personnel and communications required by commanders of unified and specified commands, and recommend the assignment of responsibilities to the military departments for providing this support. They provide guidance and direction to commanders of the unified and specified commands for the development, acquisition, and operation of the command and control systems for their commands.

(2) Review the plans and programs of the unified and specified commands and analyze the national capability to provide logistics support for

execution of their contingency plans. Since several of the contingency plans could become operational at the same time, the JCS also chooses three or more representative plans for simultaneous consideration in order to identify shortages of materiel and support capability in case of multiple commitments. This analysis is conducted at least once a year. Action is taken to overcome the logistics problems that are identified.

(3) In support of the preparation of budgets, submit to the Secretary of Defense statements of military requirements based upon strategic considerations, current national security policy, and contingency plans. These statements include tasks, priorities, force requirements, general strategic guidance for the development of military installations, and recommendations for equipping and maintaining military forces.

CHAPTER 6

LOGISTICS PLANNING RESPONSIBILITIES OF SUPPORTED AND SUPPORTING COMMANDERS

Section I. GENERAL

6-1. Introduction

The important facets of planning for military operations are the responses by the supporting activities to the guidance from the President, the National Security Council (NSC), the Secretary of Defense, the Joint Chiefs of Staff (JCS), and the concept of operations of the unified/specified commander. The latter must be translated by the planners into balanced force structures, supplies, and services to support the forces and time-phased deployment schedules. The Department of Defense (DOD) guidance is contained in DOD directives,

instructions, or other transmittals. The JCS provides guidance to the military services and the commanders of the unified/specified commands for the development and execution of general war and contingency plans in publications such as JCS Pub. 2, JCS Pub. 3, JCS Pub. 15 and volumes I and II of the Joint Operations Planning System (JOPS). The logistics planning responsibilities of the commanders of the various major supported and supporting commands and agencies, as discussed in this chapter, are intended to show the interfaces in the planning process and the coordination required.

Section II. LOGISTICS RESPONSIBILITIES OF UNIFIED COMMAND

6-2. Logistics in a Unified Command

a. There are two kinds of logistics agencies within each organization for logistics support; the policy, planning, and supervising agency and the implementing agency. The top agency (the commander and his staff) is responsible for providing logistics policy and guidance; the review of requirements; the determination or approval of operational plans concerning logistics; and the determination and allocation of logistics means when necessary. These are the command aspects of the logistics function and include the responsibility for planning and supervising the implementation of approved plans by all echelons. Logistics planning at the level of the unified command places emphasis on the command aspects of the logistics function. The implementing agency functions after the operation is approved. The top agency controls the approval of operational plans on the basis of their feasibility. The action of the implementing agency is always limited to the approved plans and subject to varying degrees of control by the top agency.

b. Some of the overall logistics functions of a US unified command are logistics and administrative support arrangements. The commander of a uni-

fied command has specific authority to coordinate the logistics support of the service components and to exercise control of distribution of logistics support when shortages necessitate. The most common type of support is Uniservice Logistics Support. Logistics support may also be provided by agreements or assignments in common servicing, cross-servicing, or joint servicing at force, theater, department, or DOD levels. One or a combination of the foregoing types of servicing can be made to work, and will provide suitable support to the US forces within a unified command. Each type of service is described below.

(1) *Uniservice.*

(a) In this type of organization, each service is responsible for the provision of all logistics support to its own forces. This eliminates the necessity for additional headquarters which are required in joint efforts.

(b) This organization does, however, cause some duplication of efforts and may cause establishment of control agencies in the unified command headquarters.

(2) *Cross-Servicing or Common Servicing.*

(a) *Cross-Servicing.* That function performed by one military service in support of another military service for which reimbursement is required from the service receiving support. Aircraft servicing would be an example of cross-servicing. Fuel used by an Army aircraft serviced at an Air Force or Navy base would eventually be charged to the Department of the Army (DA).

(b) *Common Servicing.* That function performed by one military service in support of another military service for which reimbursement is not required from the service receiving support. For example, the Army may be charged with the responsibility for budgeting and furnishing all class I supplies for Army and Air Force personnel in a theater of operations. In the interest of effective and economical operations, the service charged with this responsibility may have an integrated staff and could well have units from the other service(s) attached.

(3) *Joint Servicing.*

(a) That function performed by a jointly staffed and financed activity in support of two or more military services.

(b) For clarification, a distinction should be made between DOD agencies and unified command agencies. The Defense Logistics Agency (DLA) is in the DOD organization. The assignment of personnel to the agency must be in accordance with staffing plans approved by the Secretary of Defense which provide a balanced distribution of positions among the military services. Programing, budgeting, funding, auditing, accounting, pricing, and reporting activities of DLA are in accordance with policy and procedures established by Office of the Secretary of Defense (OSD). DLA uses appropriated funds to finance the operating costs of the agency, a stock fund to finance all inventories procured for resale and, when appropriate, an industrial fund for financing industrial-commercial type operations. On the other hand, certain logistics functions may be organized on a joint basis in a unified command. Some examples of these joint functions are:

- 1 Joint Medical Regulating Office.
- 2 Joint Petroleum Office.
- 3 Joint Transportation Board.
- 4 Joint Graves Registration Office.

6-3. Health Service Support

The commander of a unified command has the authority to coordinate health service support of the unified command. A unified command surgeon is designated for each unified command and liai-

son is established between the unified command surgeon and each component command surgeon. The duties of the unified command surgeon are normally advisory, planning, and supervisory, as they pertain to the overall medical support of the command. Health service support planning is discussed in more detail in chapter 9 and FM 8-55.

6-4. POL Support

a. The Assistant Secretary of Defense (Acquisition and Logistics) (ASD(A&L)) is responsible for establishing policies and providing guidance relating to the DOD bulk petroleum logistics programs, systems, and procedures, and acts as the DOD claimant to the Department of Energy (DOE) for petroleum products required by DOD.

b. The Director, DLA, is the Integrated Materiel Manager (IMM) for petroleum products including ownership and accountability of bulk petroleum war reserve and peacetime operating stocks. The Commander, Defense Fuel Supply Center (DFSC) is responsible for the procurement of all petroleum products, coal, and related services and is the IMM for bulk petroleum products. Packaged fuels are not stocked by DFSC, but are procured at the request of the services for direct delivery to the user.

c. The JCS is responsible for allocating petroleum products among the military departments when DOD claimant stocks are authorized and released by DOE.

d. The military services are responsible for management and ownership of war reserve and operating petroleum, oils, and lubricants (POL) stocks on base; the operation of petroleum facilities as assigned; computing bulk petroleum product requirements; computing Prepositioned War Reserve Materiel Requirements (PWRMS) for class III products based upon joint plans and service approved consumption factors; and for maintaining established levels of supply, including Prepositioned War Reserve Stock (PWRMS).

e. Commanders of unified commands coordinate class III supply matters within their commands, review and consolidate requirements within their areas, submit requirements for slated products to DFSC, and monitor established operating and PWRS supply levels. The commander of a unified command originating an Operation Plan (OPLAN) is responsible for the overall planning of class III logistics support. Each OPLAN submitted to the JCS for approval will contain a petroleum appendix to the logistics annex in the format prescribed in volume I, JOPS. Supporting commanders, in coordination with the supported commander, develop time-phased requirements for class III sup-

port during the deployment phase. Service component commanders normally are delegated responsibility for development of service support plans to include resupply of class III to forces participating in the operation.

f. The Joint Petroleum Office (JPO) is a staff office of each commander of a unified command comprised of personnel of each military service qualified in petroleum logistics. It advises the commander, coordinates petroleum logistics planning and policy, allocates petroleum products and facilities under emergency conditions, coordinates the command quality surveillance program, coordinates distribution requirements of all services within the unified commands, and acts as an agent or assistant to the DFSC. POL supply is discussed further in par. 8-11.

6-5. Transportation Services

a. The commander of a unified or specified command is responsible for coordination of the air, sea, and land transport modes available to the theater. Normally, the J-4 exercises staff supervision over allocation and use of transportation capabilities and facilities. However, based on the magnitude of transport requirements, the force commander may establish an Assistant Chief of Staff (ACS), Transportation, a staff section on the Joint Staff level for carrying out the commander's staff transportation functions.

b. A Joint Transportation Board (JTB) should be established by the commander when the transport capabilities of two or more services and allied nations are required for accomplishment of the forces' mission. The JTB is a staff agency under the supervision of the command J-4. It is composed of representatives from each of the service components and from the major joint forces. When appropriate, representatives of host and allied nations may become part of the JTB. On the basis of forecasted requirements of service components, the JTB recommends allocation of all transportation resources available to the command in accordance with priorities established by the commander. Based on the recommendations of the JTB, the commander allocates transport capability to the service components. In turn, the Theater Army suballocates to the Theater Army Transportation Command (TRANSCOM) and the corps commanders, the transport capability allocated to it.

6-6. Graves Registration Services

a. Graves registration in military operations includes the supervision and execution of matters pertaining to the identification, removal, and burial of the dead and to the collection and processing of their personal effects.

b. Inherent in the graves registration function is the search, recovery, identification, evacuation or burial of US military, allied, and enemy dead and deceased civilians under US military jurisdiction; the recovery and handling of personal effects found on the remains in the unit area; the establishment, operation, and maintenance of temporary military cemeteries until other arrangements are made for the disposition of the remains of such deceased personnel; and the maintenance of appropriate records and reports.

c. Disposition of personal effects includes the collection, receipt, recording, storage, and disposal of the personal property of US military personnel, civilians under US military jurisdiction, personnel officially accredited to the US Armed Forces, and all deceased persons for whom the United States provides graves registration services. The handling of personal effects begins at the time of initial collection by representatives of the Armed Forces and extends to the time of receipt by the authorized next of kin or representatives of the host country or allied nation, or until other disposition is made in accordance with applicable regulations.

d. During major military operations, the Armed Services Graves Registration Office-Continental United States (ASGRO-CONUS) becomes the office of record for burial data for all the military services and the control point for promulgation of joint graves registration plans, principles, and doctrine developed in coordination with and concurred in by the appropriate departments. Appropriate records are prepared and submitted through service channels to the ASGRO.

e. Commanders of unified commands are responsible for including in their OPLANs provision for the overall supervision of matters pertaining to graves registration and disposition of personal effects in support of specific operations. Responsibilities include:

(1) Providing broad guidance to their service component commanders.

(2) Designating a service component to be responsible for operation of one or more collection points and for disposition of remains, including temporary interment, cemetery maintenance, and recordkeeping, until other provisions are made for subsequent custody.

(3) Establishing and operating a Joint Central Graves Registration Office (JCGRO) and subarea offices as necessary.

(4) Providing procedural guidance concerning transfer of enemy and allied remains and their personal effects to custody of another government,

including maintenance of the records required by the 1949 Geneva Conventions for the Protection of War Victims.

(5) Providing guidance on the removal and burial of contaminated remains.

f. The military services are responsible for the provision of graves registration and personal effects disposition services for their own forces and for such other personnel as may be present. However, any service may assume responsibility for provision of these services for another service upon prior mutual agreement.

g. The functions of the JCGRO include maintaining data on burial and recovery status of all dead and missing; coordinating programs for search, recovery, identification, burial, or concurrent return of remains; supervising the establishment and maintenance of temporary cemeteries; and serving as a clearing point for graves registration information. The principal JCGRO is jointly staffed by representatives from service components in the unified command. Subordinate JCGROs are manned by representatives of those services whose forces are operating in the area served by the suboffice.

h. Commanders are responsible for recovery and evacuation of the remains of deceased personnel of their respective organizations to a designated collecting point, including safeguarding of personal effects. In joint operations in which US Army forces are involved, the US Army component commander is assigned responsibility for the acceptance at a designated collecting point and disposition of remains of all the services. In the event the US Army component is not involved, the US Navy is assigned these responsibilities.

i. When necessary, the remains of US civilian, allied, prisoners of war (PW), and enemy dead are handled in a manner similar to that prescribed for deceased US military. To the extent possible, the same records and reports will be maintained for future use. However, individual cemeteries are established for the separate burial of allied and enemy dead. When circumstances require interment in a US temporary cemetery, separate plots or sections are provided for US, allied, and enemy deceased. Personal effects of allied dead are evacuated through logistics channels to the point specified for reversion to representatives of the nation concerned. Processing of the remains and personal effects of PWs is in accordance with the 1949 Geneva Conventions. Personal effects of enemy dead not afforded PW status are evacuated to the theater effects depots pending disposition instructions from the Joint Chiefs of Staff.

j. Additional discussion of Joint Graves Registration is found in Joint Manual DA FM 10-63/NAUMED P-5016/AFM 143-3/NAVMC 2509-A.

6-7. Supply

a. Responsibilities.

(1) *Unified Commander.*

(a) The commander of a unified command is responsible for effective coordinated supply support within his command and for insuring that statements of requirements of his forces are prepared and submitted in accordance with existing directives of the Secretary of Defense, the departmental Secretaries and the Chiefs of Services. He is also responsible for insuring that stated requirements for categories of items of common supply cover the needs of all forces, and that duplications are eliminated.

(b) The unified commander coordinates the supply functions of the component forces through their commanders to provide the maximum balanced program and economy necessary to promote military effectiveness. The extent to which this authority is exercised is usually more limited in peacetime than during war.

(c) The commander of a unified command recommends the priority of the phase buildup of supplies, installations, and organizations deemed essential to mission accomplishment.

(d) The commander of a unified command is responsible for provision of supplies to civilians in occupied areas, in accordance with current directives.

(e) Within a US unified command, supply support is normally furnished on a uniservice basis. However, under wartime conditions, the commander of the unified command is authorized to use the facilities and supplies of all forces assigned to his command as necessary to accomplish his mission. The unified command joint staff assists the commander in carrying out these general responsibilities by:

1 Developing overall policies and procedures concerning:

- (a) Supply distribution.
- (b) Levels of supply, including phased buildup.
- (c) Maintenance and repair.
- (d) Procurement.
- (e) Allocation of critical classes and items of supply.

(f) Allocation of supplies to civilians in an occupied area.

2 Reviewing the supply requirements of the component forces to the extent necessary to eliminate duplication and insure that needs of all forces are included.

3 Conducting supply planning concurrently with other planning.

4 Establishing supply priorities to insure a balanced program for various phases of operations.

(2) *Commanders of Service Components.* Subject to the responsibility and authority of the commander of a unified command, commanders of the service components are responsible for supply of their commands. They will communicate directly with appropriate headquarters on all supply matters, except on those matters which the commander of the unified command directs be forwarded through him. They will keep the commander of the unified command informed of the status of important supply matters affecting readiness of his force.

(3) *Subordinate Commanders.* Subordinate commanders may be assigned the responsibility for providing supply support to elements or individuals of other services within the unified command.

(4) *Joint Task Forces.* Normally, supply responsibilities follow unilateral command channels except when:

(a) Specifically directed otherwise by the authority establishing that force.

(b) Common, joint, or cross-servicing agreements and procedures provide otherwise.

(c) The commander of a joint task force exercises supply coordination or control, including the allocation of supplies to subordinate commanders which are essential to the success of his mission.

b. Supply Control.

(1) The supply control system is used to inform the command of the overall status of the supply situation and is a factor in strategical, tactical, and logistical planning. It forms the basis upon which to:

(a) Forecast requirements.

(b) Distribute supplies.

(c) Allocate critical items.

(d) Allocate transportation.

(e) Determine movements.

(2) Stock control considers all present and future demands for materiel, including unservice-

able but reparable items and is primarily concerned with the quantity of supplies available, their condition, and location.

(3) The objective of the supply control system is to provide the means of maintaining the best possible balance between total supply and total demand. It is designed to insure provision of supplies on time, to prevent the accumulation of excess stock, and to determine the total amount of stock on hand for distribution.

(4) Supply control is a function of all levels of command. For example, the unified commander is concerned with overall tonnage of supply requirements, critical items in short supply, average consumption rates expressed in days per man or gross tonnage, and guidance policies of a general nature. The component or uniservice commander would be concerned with more exacting tonnage and volume requirements; past, present, and future status of individual items in addition to critical items; consumption rates in more detail; and policies of a more specific nature.

c. Supply Requirements.

(1) Supply requirements are defined as computed needs for supplies necessary to equip, maintain, and operate a force for a specific period of time.

(2) Timely forecasts must be prepared by every commander for pending operations. Requirements forecasting is done at all levels since the respective services alone have the means and information with which to forecast requirements. In forecasting requirements, the service component commander represents the highest echelon that is involved in the oversea area. The commander of a unified command reviews the requirements of his component commanders to the extent necessary to insure that they are adequate and justified. The commander of a unified command is particularly interested in those supply items in which there are critical shortages or which require large amounts of transportation (such as POL, ammunition, construction material, etc.). Successful requirements planning is dependent on accurate, adequate, and timely statistics as well as sound judgment. The J-4, with the assistance of the special staff, performs the following:

(a) Detailed review of critical items to provide sound basis for allocation to various forces.

(b) Detailed review of items requiring large amounts of transportation to permit equitable allocation of available transportation to various forces.

(c) Spot check of all other items to determine that requirements are adequate and justified.

(3) In order to accomplish this review, the J-4 must have knowledge of the factors used by the component forces in computing requirements. Using a sampling technique, the J-4 will apply broad factors as well as judgment to determine that component requirements are not excessive and that the needs of all forces are included. Previous experience with supply consumption should provide a yardstick for the evaluation of supply requirements. Planning factors are used by all levels of command mainly for forecasting and reviewing supply requirements. Factors may be wide and varied or tailored to individual situations. Generally, the higher the command level, the broader the factors become. For broad planning purposes at unified command level, the division slice, the wing slice, etc., are used. However, such broad factors are of value primarily for relating supply to the need for transportation. Many factors must be considered in forecasting for an over-sea area, among which are:

- (a) The number of troops and rate of build-up.
- (b) Availability of supplies from maintenance facilities (repair and rebuild) and indigenous resources.
- (c) Characteristics of the area as to land masses, water areas, climate, weather, and terrain.
- (d) Characteristics of lines of communication—roads, railroads, sea lanes, air lanes, inland waterways, bases, ports, harbors, storage facilities, utilities, and signal communications.
- (e) Type of operations expected—attack, defense, occupation, ground, sea, air-amphibious, air-borne—and degree of activity.
- (f) Facilities required,
- (g) Anticipated losses and capability of enemy to interfere with lines of communication.
- (h) Time and space factors,
- (i) Past experience.

(4) The commander of a unified command reviews requirements of the service components of his command and coordinates priorities and programs. He reviews the recommendations of component commanders to their parent military departments to verify that the recommendations are in agreement with his plans and programs.

(5) Ordinarily, the requirements of forces of allied nations are furnished by the parent nation. A US unified command may, as a result of bilateral agreements, provide support to the forces of allied nations. In the latter instance, the requirements for forces of allied nations would be

screened by the US unified command to insure that requirements are within the policies set forth in the agreement and that issue would not impair the effectiveness of US forces. In cases where the forces of the allied nations in question are operating under an allied commander, the requirements should be screened in the light of policies established by the allied commander.

d. Levels of Supply. The supplies to be furnished to an oversea command and the supply levels to be maintained are developed by the respective military department and the commander of the oversea command, and may be reviewed by the Joint Chiefs of Staff and approved by the Secretary of Defense after review for adequacy and justification. These levels are expressed in days of supply by supply class as defined in AR 700-9.

e. Supply Acquisition.

(1) Supply acquisition is the process of obtaining and introducing supplies into the military supply system. Requisitioning is properly a function of distribution and should not be used synonymously with acquisition.

(2) Acquisition of supplies in oversea commands is effected through local purchase, reverse lend-lease, local manufacture, capture, seizure, findings, and gifts. Supplies from available local resources are utilized to the fullest in order to save time, transportation, and national resources. Desirable items for offshore acquisition are those involving large tonnages such as food, POL, and construction materials. Maximum usage of indigenous products should be encouraged, keeping in mind the needs of the host nations.

f. Storage. Storage is the keeping or placing of property in a warehouse, shed, open area, or other designated facility. Storage is a continuation of the receiving operation and is preliminary to the shipping or issuing operations (AR 310-25).

(1) Storage includes planning for facilities, selection of sites for storage installations, allocation of storage space, internal arrangements of storage installations, segregation of stocks, and types of storage installations to be used.

(2) Some of the factors to be considered in the selection of storage sites include: mission, lines of communication (internal and external road, rail, air, and water networks), topography, drainage, hardstands, water, space, facilities, and signal communications. Full use is made of existing buildings and facilities. Provision must be made for adequate cover, dispersion, and protection.

(3) Allocation of available storage space and facilities between the component forces is the re-

sponsibility of the commander of the unified command. Each command must establish priorities and compute requirements for storage to include refrigerated, covered, and open storage, tankage, and hardstands. After facilities have been assigned, the actual operation for storage will be conducted under the component commander.

g. Supply Distribution.

(1) Supply distribution includes the receipt, storage, instorage maintenance, transportation, and issue of materiel. Distribution methods may be prescribed by the commander of a unified command, while the function of distribution itself is a responsibility of the component commanders.

(2) The commander of a unified command is responsible for insuring that necessary distribution policies and procedures are established by the commanders of the service components of his command. The service components should use their normal distribution system and indigenous distribution facilities.

(3) The categories of supply distribution are preplanned supply, scheduled supply, or supply by requisition.

(a) Replanned Supply. Preplanned supply is the provisioning of those supplies necessary to sustain a force for a specified period (usually until normal supply procedures can be implemented). Preplanned supply is based upon estimated or experience-usage factors, and is continued until inventory control procedures are established in the area.

(b) Scheduled Supply. Scheduled supply is a system by which certain specified items are shipped on the basis of periodic reports of the status of stocks on hand or enroute to the using agency. This system may be used as an interim measure between preplanned supply and supply by requisition for heavy-use items (rations, POL, and ammunition) on the basis of strength reports, POL and ammunition expenditure reports, etc., while the force would submit requisitions for other items. Use of this system requires a partial build-up of supply levels in the oversea area or objective area.

(c) Supply by Requisitions. Supply by requisition is a system by which supplies required to meet the needs of units, activities, or forces are supplied on the basis of requisitions initiated by the using agency. This is the normal system of supply and should be instituted as soon as possible. However, it should be used only after supply control measures are established. The time required for this transition is variable and depends on the availability of shipping; accuracy of initial esti-

mates; availability of supplies; training of personnel including supply discipline; available storage; communications; speed and rate of buildup; and many other factors.

6-8. Maintenance Services

a. Each of the services represented in a unified or specified command is normally responsible for maintenance support for its own forces. Normally, existing policies and procedures of the services represented in the command are used for the provision of maintenance and other combat service support, and the service component commander (e.g., theater Army commander) exercises control to insure that such support is provided. The commander of the unified or specified command, however, has the authority to coordinate logistics policies and procedures through the separate military commanders of component forces, and to influence the logistics effort to the extent required to carry out his assigned missions, tasks, and responsibilities.

b. The unified commander exercises directive authority to insure effective operations and to prevent or eliminate duplication of facilities and overlapping of functions among the service components of the command. The directive authority of the commander of a unified or specified command extends to the coordination, as necessary, of:

(1) Acquisition, storage, movement, distribution, maintenance, evacuation, and disposition of materiel, to include repair parts.

(2) Acquisition or furnishing of services.

(3) Acquisition or construction, maintenance, operation, and disposition of facilities.

c. The unified commander also:

(1) Disseminates information on the overall plans and programs of the command to the component commanders to enable them to exercise planning and management within their areas of responsibility and in order to provide a basis for requirements determination.

(2) Reviews requirements of the service components and coordinates priorities and programs to effectively utilize maintenance services.

(3) May direct the establishment of maintenance facilities for joint use; e.g., a primary calibration facility.

(4) Indicates, by directive, the type of information and communications on supply and maintenance matters that will be submitted to or through the command headquarters and those matters on which service components may commu-

nicate directly with their respective military departments.

(5) Establishes the necessary reports and methods of obtaining requirements of allied forces that are logistically supported by US forces so that these data may be included in the command's requirements report.

6-9. Other Logistics Responsibilities

Other logistics responsibilities of a unified command are:

a. Salvage. The commander of a unified command is responsible for coordinating salvage procedures within his command.

b. Base Development. The commander of a unified command is responsible for:

(1) Establishment of bases within the limits of resources furnished to accomplish his mission, and plans and coordinates their development in accordance with approved joint and service plans.

(2) The coordination of real estate requirements and construction of facilities within the command and the establishment of priorities for construction projects.

(3) Assignment of existing facilities to the elements of his command. In occupied areas, maximum utilization should be made of local facilities. In recognition of departmental responsibility for facility funding and support (with the exception of emergency circumstances) no reassignment of existing facilities between services, or assignment action affecting the owning service's utilization, will be effected without the concurrence of services concerned.

c. Air and Water Ports. Responsibilities for operation of air and water ports outside the continental limits of the United States, essential to logistics support of the unified command are assigned by the commander of the unified command. Normally, the establishment and operation of water ports will be a responsibility of the Army. Exception to the policy can be made in the case of water ports primarily serving the Navy or the Air Force. However, the Army is the major user of water port facilities for debarkation and incoming supplies. In its Transportation Corps the Army has units designed, equipped, and trained for the accomplishment of water port operations.

d. Acquisition. The commander of a unified command is responsible for establishment of acquisition policies within his command consistent with applicable laws, departmental regulations, and Federal Acquisition Regulation (FAR).

e. Military Government. The commander of a unified command is responsible for coordinating the logistics support of military government in areas occupied by his command.

f. Military Sealift Command (MSC) and Military Airlift Command (MAC). The facilities and supplies provided and required for the support of MSC and MAC are specifically exempted from the logistics authority of the commander of a unified command.

g. Recovery and Evacuation Equipment. The commander of a unified command should monitor the availability and allocation of critical specialized recovery and evacuation equipment.

Section III. LOGISTICS PLANNING BY SUPPORTED AND SUPPORTING COMMANDS AND AGENCIES

6-10. Plans of the Commanders of Supported Unified/Specified Commands

a. Operations plans of the supported unified/specified commands include as part of that plan the commander's concept for providing logistics support for conducting the operations. This concept should describe and define command responsibilities and functional alignment in sufficient detail as the basis for detailed logistics support plans, and to insure that all essential logistics tasks and evaluations required are provided for. Host nation support agreements, commercial contractor support, interoperability, and inter-Government support agreements should be described in the commander's concept.

b. Operation planning and logistics planning should be coordinated so that support problems can be identified and resolved prior to the implementation of the plan. It is essential that logistical and operation planning be conducted concurrently during the development of time-phased force deployment lists (TPFDL) to insure the adequacy of logistics support and combat service support units as well as the capability to logistically support the planned force buildup.

c. Logistics plans of the supported command should adequately address:

(1) Significant time-phased materiel requirements, including construction materials and equipment (expressed in short tons, cube, square feet,

and outsize cargo), facilities, and other resources necessary to support the OPLAN.

(2) The capabilities and limitations of water and air terminals, ports, and beaches in the operational area. This insures the ability of the gaining command to receive and support deploying forces, their accompanying supplies, resupplies, and replacement personnel.

(3) Support methods and procedures needed to operate the air, sea, and land lines of communication.

(4) The means to coordinate and control the flow of materiel into the contingency area so the throughput and lift capabilities and command requirements are not exceeded.

(5) The interrelationship between the intertheater and intratheater lines of communication.

(6) Significant assumptions which can influence the validity of the overall operational concept.

(7) The logistics support tasks assigned to the component commands.

(8) The establishment of priorities and programs for materiel.

(9) Interservice and, where applicable, international support agreements to insure efficient utilization of resources.

(10) Provision for communications both within and outside the operation area in support of logistics requirements.

(11) Sealift and airlift forces needed to support deployed forces.

(12) Transportation resources to move forces and their accompanying supplies to the objective area.

(13) Prepositioning of materiel, including construction materials and equipment to develop bases to support the operation.

(14) High-priority materiel needed at the outset of an operation.

(15) Follow-on airlift or sealift to move into the contingency area those units and items not needed initially in the operation.

(16) Maintenance resources to insure the highest return of damaged/inoperable equipment to use.

d. Specific guidance for providing materiel and services of a critical or sensitive nature is contained in appendixes of the logistics annex to the OPLAN.

(1) The POL appendix provides the concept of petroleum supply operations; requirements for petroleum products for US forces, allied forces, and civilian agencies; onhand or available stocks; capa-

bility of handling and storage facilities; and construction of new facilities required.

(2) Provision for the overall supervision of matters pertaining to graves registration and disposition of personal effects of US military personnel, civilians under US military jurisdiction, and all other deceased personnel for whom the United States provides graves registration services is included in a graves registration appendix. (See paragraph 6-6.)

(3) The medical appendix provides the concept for medical services. (See also paragraph 6-3 and chapter 8.)

(4) The transportation appendix provides the concept for transportation support. The detailed time-phased movements requirements and other data in the supported commander's OPLAN provide the basis for planning by the transportation operating agencies (TOA) for sealift and airlift from CONUS to oversea areas, and movements within and between oversea areas.

(5) Because of the importance of having adequate base facilities to support a military operation, the civil engineering support plan (CESP) is included as a separate appendix to the logistics annex of the OPLAN of the unified command, unless it is more appropriate that it be included in the OPLAN of a Joint Task Force (JTF) or subordinate unified command. In the latter instance the logistics annex to the unified command OPLAN will identify:

(a) Restriction on use of bases or facilities.

(b) Service component having primary responsibility for the CESP,

(c) Planning factors to be used and major construction resources to be allocated.

(d) Set standards of construction.

(e) Outline responsibility for construction, construction management, and facility utilization.

(f) Set priorities and time-phased requirements.

(g) Provide for withdrawal or disposition of residual assets.

(6) Each OPLAN prepared by the commander of a unified or specified command and submitted to the JCS for approval includes a nonnuclear ammunition appendix to the logistics annex. This appendix includes:

(a) The concept of ammunition supply and resupply operations.

(b) Ammunition requirements to support the OPLAN to include requirements of assigned US forces.

(c) Forces being assigned and/or provided by other commanders.

(d) Allied forces and other agencies to be supported from US military stocks.

(e) Available stocks on hand.

(f) Availability and capability of storage and handling facilities planned for use in joint agreements.

(g) Ammunition handling systems required to support the plan.

6-11. Role of the Supporting Unified Command

a. OPLANS of the oversea unified commands may require that assigned forces be augmented by forces of another oversea unified command or those of US-based forces of the United States Readiness Command (USREDCOM). The major missions of USREDCOM are to control US-based combat ready forces and to provide a general reserve of these forces to reinforce oversea unified commands. Staff planners of USREDCOM participate with staff planners of other commands in the development of contingency plans which would require reinforcement from the United States. In addition USREDCOM maintains liaison officers with the Pacific Command and European Command to facilitate reinforcement of those commands by USREDCOM.

b. USREDCOM has Army and Air Force components. The Army component, US Army Forces Readiness Command (USARRED) is made up of the forces of the US Army Forces Command (FORSCOM). In the development of Army component supporting plans to the USREDCOM OPLANS, the Commander USARRED/FORSCOM may designate one of the assigned Army Corps as the planning agent to develop supporting OPLANS.

c. The Army component planning agent, based on guidance contained in the supported commander's OPLAN and that received from FORSCOM/USARRED, develops his supporting plans. Generally, the guidance the supporting unified commander receives from the supported unified commander is quite broad. The interests of the supported commander generally involve the numbers of people and the short tons of supplies and equipment to be moved into the operational area within a given time frame and within available transportation resources. The supporting commander or his planning agent must translate this broad guidance

into detailed force requirements, force routing data, and necessary guidance for use by subordinate commands and other supporting commands, agencies, and activities for developing their plans. For example, the TPFDL identifies units, tonnages of accompanying supplies, and resupply items and schedules for their movement into the objective area. It is the supporting commander's responsibility to provide guidance for the computation of accompanying supplies, time-phased preplanned supply, authorized stockage lists (ASL) items, and to provide appropriate combat service support units or elements to enter the objective area at an early date to rapidly bring under control the preplanned supply packages.

d. Logistics guidance in the plans of the supporting command should provide for:

- (1) Standard movement planning procedures.
- (2) Authorization for special and discretionary items of equipment for deploying forces.
- (3) Identity of units and forces to be supported by each combat service support unit and their locations and specific logistics support missions to be accomplished in objective area.
- (4) Phased stockage objective (safety/operating levels) to be attained for each class of supply.
- (5) Rates of use and/or consumption replacement factors to be used for computing preplanned supply requirements.
- (6) Operational projects requirements and peculiar equipment support requirements.
- (7) Instructions for developing ASLs, prescribed loads and mission loads.
- (8) Mission assignments and movements schedule priorities.
- (9) Tables of Organization and Equipment/Modified TOE (TOE/ MTOE), Tables of Distribution and Allowances/Modified TDA (TDA/MTDA), and Common Tables of Allowances (CTA) item requirements.
- (10) Requirements for base development plans and base development and field fortification/barrier materiel requirements.
- (11) Ammunition supply factors and computation of basic load.
- (12) Level of maintenance to be performed and introduction of maintenance units into the objective area.
- (13) Funding requirements.
- (14) Procurement support.
- (15) Utilization of War Reserve Stocks.

(16) Common Item Support Requirements for other US forces planned for deployment/employment.

(17) Initial assault force requirements.

(18) Enroute support to port of embarkation (POE), including medical support.

(19) Nondeployable equipment.

(20) Emergency air-delivered supplies.

(21) Requirements for phasing preplanned supply into the area to include:

(a) Special packaging and palletizing requirements.

(b) Special instructions for delivery of preplanned supply.

(c) Identification of fragmented units.

(22) Retrograde of materiel.

e. The Commander, FORSCOM, has been assigned the mission to provide force generation planning for contingencies, deployment, domestic emergencies, and mobilization. This includes the selection of available units to fulfill force requirements and the determination of movement requirements for each troop unit selected. Through the use of the computer support provided by the Worldwide Military Command and Control System (WWMCCS), the Unit Reporting (UNITREP) Systems and its own Computerized Movement Planning and Status System (COMPASS), FORSCOM accomplishes the assigned mission. The FORSTAT System provides FORSCOM with the capability to select the units required for the force structure. COMPASS maintains deployment unit movement data (UMD) for TOE authorizations to include forces in CONUS based on expected deployment requirements including accompanying supplies for "administrative deployment"; "Prepositioning of Materiel Configured to Unit Sets (POMCUS)" UMD for equipment of POMCUS units not prepositioned in an oversea theater; and Mobilization UMD for all active and Reserve units showing commercial transportation movement requirements from their home station to their mobilization installation. Since the "Standard" UMD is based on reports submitted by units, it is imperative that the data reported are accurate and the commander's movement requirements are based on the guidance or directives applicable to a specific mission (mobilization or deployment). To assist the unit commander and to provide technical guidance in movement planning and UMD reporting, FORSCOM requires that each of its installations appoint a unit movement coordinator. FORSCOM Regulation 55-1 prescribes the policy, establishes procedures and assigns responsibilities for unit movement planning.

6-12. Role of the Department of Army

a. Military operations are conducted by forces under the operational command of the unified and specified commands. The major combat elements of these forces (Army Divisions, Air Wings, Navy Task Forces) are apportioned for planning purposes to the unified or specified commands through joint channels. On the basis of the allocated combat forces, the services allocate the combat support and combat service support forces required to enhance the combat effectiveness of the major combat forces and to maintain a sustained combat capability to provide the essential support services. The military services are responsible for the administration of their components except for the exercise of operational command/control. The responsibilities of the services include the provision of filler and replacement personnel and providing adequate logistical support for operational forces assigned to unified commands. The services are also responsible for determining the total logistics support required for active US forces and those forces planned to be mobilized or activated to support the operational commander's OPLAN. The unified commander's OPLANs are reviewed by the services to determine force availability and force list balance, the adequacy and feasibility of logistics support, and to assess their capabilities to provide logistics support.

b. DA, in carrying out its responsibilities, has delegated much of its planning authority to Army component commands of unified commands and joint forces and to other major Army commands. The Army component commands develop the Army portion of the TPFDL for each supported commander's OPLAN. Within DA, the Deputy Chief of Staff for Operations (DCSOPS) is the point of contact with JCS and is the DA reviewing and approving authority for Army force requirements identified on the TPFDL. Similarly, the Army component commands provide nonunit records for non unit resupply and filler/replacement personnel requirements. Other planning involvement consists primarily of providing policy and procedural guidance to the Army component and other major Army commanders. These policies and procedures relating to the logistics aspects of joint planning include:

(1) Funding guidance.

(2) Planning factors.

(3) Establishment of theater Army stockage levels (see AR 11-11).

(4) Base development policies.

(5) Strategic mobility planning to include review of war and contingency plans of unified and specified commands.

(6) Force structure development and development of preferred mobility force levels of airlift and sealift.

(7) Establishment of priorities for logistics resources controlled by the Department of the Army for initial support of deployed/employed forces (see AR 11-12).

(8) Single supply pipeline system for support of other services elements and allied forces (see AR 700-7).

(9) Management of war reserve stocks (see par. 4-8, AR 11-8).

(10) Guidance for development, review, and approval of operational projects.

(11) Evaluating, coordinating, directing, and reporting on logistical actions pertaining to exercises and the testing of operational plans.

(12) Evaluating and coordinating organization and functions of joint, unified, and specified commands, and the Army components thereof, in matters relating to logistics support operations.

c. The adequacy of plans to support the supported unified commander's OPLAN is a matter between the commander and the supporting commanders. Problems that cannot be resolved satisfactorily may be referred to the JCS for resolution. Problem areas uncovered during the JCS review may be referred to the military service for necessary action. DA Staff offices may become involved in such matters on an "exception" basis when requested by the JCS. Since many conditions upon which OPLANs were developed undergo frequent change, it is necessary that the DA Staff periodically review with the Army component commands the Army capability to support the approved OPLAN. These reviews should seek to increase efficiency and to eliminate duplication and unnecessary expenditures within the framework of the existing logistics structure. Should any logistics deficiencies develop which would restrict or delay the execution of approved plans, the JCS and the appropriate unified commander should be immediately notified. These deficiencies should form the basis for necessary programing and budgeting action to acquire materiel and services to attain the required readiness posture and serve as justification to the Congress for the DA portion of the DOD budget.

6-13. The Role of US Army Materiel Command (AMC)

a. The Commander (CDR), AMC is responsible under general guidance of HQDA, for managing

and operating Army wholesale logistics in conjunction with The Surgeon General (TSG), US Army Intelligence and Security Command (INSCOM), Army Information Systems Command (AISC), and Military Traffic Management Command (MTMC). Within this responsibility, the AMC mission charges the CDR, AMC to furnish timely and effective supply and maintenance support to the Army elements of the unified and specified commands and to other customers as authorized.

b. The CDR, AMC has been designated as the DA coordinating authority for the provision of pre-planned supply support (less accompanying supplies and medical supplies) to US Army forces designated to support an approved OPLAN. He has also been designated as the single point of contact for the DA major commands and other DOD agencies, the General Services Administration (GSA), and other military services for arranging supply support for the OPLANs of the supported command. In arranging this support, the CDR, AMC is authorized to deal directly with Army component commands of unified and specified commands, DA major commands, DA Staff agencies, and DOD and Federal supply and transportation agencies. The plans prepared by the CDR, AMC in support of OPLANs will include the supply plan of TSG. AMC planning is discussed in chapter 7.

6-14. Support of Communications Systems and Equipment Assigned to the US Army Information Systems Command

a. Using the logistics guidance in the plans of the Army component of a unified command or a designated planning agent as amplified by CDR, AMC, the US Army Communications Security Logistics Activity (CSLA), an element of AMC's US Army Communications-Electronics Command (CECOM), computes supply requirements and provides materiel under its cognizance to support the AMC Logistics Plan (LOGPLAN). In addition, the CSLA prepares transportation movement requirements data (TMRD) for managed supply items and transmits this data to AMC for consolidation and subsequent transmittal to the Joint Development Agency (JDA) and the TOAs.

b. The Army's nontactical telecommunications network, to include the Army portion of the Defense Communications System (DCS), nontactical Air Traffic Control (ATC), and base (post, camp, and station) communications systems is a worldwide complex of communications networks and control centers that are integrated into a single, compatible, long-haul, general-purpose system.

Within a theater of operations, the Theater Army Communications System (TACS) interfaces with the DCS at theater access points, and the communications systems of combat zones and air defense commands. The TACS includes all communications, organizations, and facilities above corps level or the largest tactical maneuver unit except DCS and air defense. The TACS is established and operated by the US Army Information Systems Command (USAISC) major subordinate command. The DCS facilities may be operated by any of the military services in a theater or area of operations, however, where the Army is the operator of the DCS, the responsibility is assigned to USAISC. Operational characteristics and requirements for these communication-electronic (C-E) integrated systems dictate the need to be supported by a dedicated retail logistics system.

c. Offsite maintenance support (that done in-shop rather than onsite) for USAISC C-E equipment (less communications security (COMSEC)) is provided by the Area Maintenance and Supply Facility (AMSF). The AMSF normally provides intermediate C-E maintenance support to USAISC units within a theater of operations. The AMSF may also provide intermediate maintenance on unique C-E equipment to overseas US agencies and forces, where appropriate. Depot maintenance support for all USAISC C-E equipment will be provided by CONUS depots designated by HQDA or the national level materiel manager. The AMSF also provides centralized retail logistics support for USAISC organic telecommunications equipment and other C-E equipment assigned.

d. COMSEC equipment logistics support is provided by COMSEC Logistics Support Units (CLSU) and Specialized Repair Activities (SRA) at the intermediate level. Depot maintenance support of all COMSEC equipment is provided by CONUS depots designated by HQDA or the national materiel manager.

6-15. DLA Support

a. The DLA is directly responsible to the Secretary of Defense for providing supplies and services used in common by the military services. The military services determine their requirements for this materiel and establish their own priorities. DLA supply centers, based on the services requirements determinations, compute consolidated requirements, procure the supplies from commercial sources, and maintain stocks to meet the military needs.

b. DLA carries out its supply support responsibilities through its six commodity-oriented supply centers and several depots backed by other Gov-

ernment-owned facilities and by commercial organizations working under Government contract. Six of the depots are classed as principal distribution depots. Each of these depots stocks a wide range of commodities and provides supply support to all activities within a designated geographical area.

c. In support of an OPLAN of Army component commands of unified commands, DLA provides materiel under its management responsibility upon request from an NICP/Service Item Control Center (SICC). DLA, also upon the request of an NICP/SICC, provides estimates of its capabilities to provide DLA-managed items to support a specified OPLAN.

d. DLA operates under the Military Standard Systems (Military Standard Requisitioning and Issue Procedures (MILSTRIP), Uniform Materiel Movement and Issue Priority System (UMMIPS), Military Standard Transportation and Movement Procedures (MILSTAMP), etc.) concept utilizing the DCS, and the Defense Automatic Address System (DAAS). The management of bulk petroleum is currently covered by the Military Standard Petroleum System (MILSPETS). These procedures are contained in DOD 4140.25-M, "Procedures for the Management of Petroleum Products."

6-16. GSA Support

a. The GSA, through its Office of Federal Supply and Services (FSS), provides worldwide supply support to military and civil agencies for those supply classes and items which have been assigned under the National Supply System concept. These items are normally identified as items which are available in the commercial market and are not weapons related or peculiar to a single military agency program. FSS conducts complete supply operations in each of its 10 GSA regions. All regional offices are responsible for processing requisitions, the management of inventories at distribution facilities, and the procurement of nonstock items for direct delivery from vendors to requisitioning agencies. The distribution of supplies is accomplished through a nationwide network of supply distribution facilities and self-service stores. FSS interfaces with DOD by use of a standardized requisitioning and priority system which is compatible with the Military Standard Systems (MILSTRIP, UMMIPS, MILSTAMP, etc.).

b. The primary methods of supply used by FSS in carrying out supply and service support responsibilities are as follows:

(1) The stock program which includes common-use, repetitive, demand-type items procured and stocked in distribution facilities and

self-service stores. FSS, through a requirements forecasting system, maintains inventory levels of these items to support the projected demands. When an OPLAN is executed, NICP/SICC will forward the requisitions to FSS for action. If the OPLAN requirements for a stock item are of an unusual magnitude, the requirements are converted to direct delivery from the supplier when feasible.

(2) The FSS Program is used for items which are generally not economical to stock, have a wide range of variable characteristics requiring selectivity in procurement, or are available at reasonable costs directly from the nationwide distribution system of the manufacturer. Contracts are established with suppliers covering a given period of time for supplies and services at fixed prices. Requiring installations or activities issue purchase orders directly to the contractor.

(3) Direct delivery procurement is used by FSS for items which are requisitioned by agencies and are neither stocked in supply distribution facilities nor available through FSS contracts. It also encompasses consolidated purchasing of certain commodities such as passenger and freight-carrying motor vehicles, and special buying services requested by agencies that rely on FSS technical knowledge.

c. Requisitioning and billing instructions:

(1) Normal MILSTRIP requisitioning procedures are followed in support of OPLANs. When emergency conditions require such procedures to be altered, GSA issues appropriate instructions.

(2) Requisitions are processed for shipment in accordance with the assigned MILSTRIP priority designator codes, unless otherwise directed by higher authority.

(3) Requisitions are accepted in any format and by whatever means of communication available under emergency conditions. A manual requisition processing system will be placed into effect if GSA loses machine capability.

(4) GSA may ship a substitute item when the requested item is either not available from any source or the item cannot be obtained in time to meet their required delivery date (RDD).

(5) All issue transactions are documented by GSA in accordance with established supply procedures. The latest edition of the GSA Supply Catalog is used for determining the price of issue from stock. If normal billing procedures are disrupted, procedures will be modified as required to insure expeditious supply support operations.

d. FSS will use any means of transportation which is available to effect delivery. If premium

transportation is required to meet the RDD, the costs will be included in the billing.

e. Communications:

(1) The GSA Federal Telecommunications System Network facilities are interconnected with the military automatic digital network (AUTODIN). All military requisitions and related communications originated worldwide are transmitted via AUTODIN and GSA traffic is entered into GSA switching facilities and automatically distributed to the appropriate supply distribution facility.

(2) GSA is a full participant in the DAAS which addresses supply documents for proper routing through the communications facilities to the recorded integrated manager.

(3) Classified messages can be sent and received between GSA and military services through a secure tie-in to the AUTODIN.

f. Liaison Contacts:

(1) In defense emergency conditions (DEFCON 3 or higher), FSS may activate Emergency Coordination Centers (ECC) at the central office and in each region to provide 24-hour continuous service to monitor high priority requirements including assistance for specialized procurements and expedited deliveries and determining availability of critically needed items. At the time of activation, FSS will contact military agency supply officials on record with GSA to coordinate supply support actions.

(2) FSS provides field liaison service to military and civil agencies through its Customer Service Bureaus (CSB) Program. CSBs are located in the central office, each GSA region, and Europe. If problems arise concerning adequate support, the CSB at the applicable GSA region should be contacted for assistance in resolution of the problem(s).

(3) FSS provides for 24-hour support service to process emergency requirements. The names and telephone numbers of persons to contact in the regions are published in regional bulletins or notices. The GSA Supply Catalog also records the emergency telephone numbers of the regions.

6-17. TOA Support

The MTMC, the MSC, and the MAC have been designated single managers charged with providing transportation support within their charters and normal operational environment. In general, they provide transportation within and outside CONUS, operate user ocean terminals, and worldwide air terminals. The TOAs are involved in the development of plans early in the concept develop-

ment process by participating in planning conferences and coordination of various planning documents. When the service component commands and supporting commands complete their supporting plans, the TOAs, utilizing the TMRD provided by these commands, develop preliminary movement tables. These preliminary movement tables, when approved, become part of the time-phased force deployment data (TPFDD) package. Appropriate TOAs are responsible for the development of detailed movement tables and schedules for the movement of forces and resources. Although not formally a part of JOPS III, the TOA automatic data processing (ADP) systems support the joint-planning function with command-unique systems to provide movement tables for the JOPS community. These ADP systems are described below in the discussion of the specific functions of each agency.

a. Military Traffic Management Command.

(1) By DODD 5160.53, MTMC is chartered in part as the single-manager operating agency for traffic management support for movement of defense freight within and from CONUS; operating common-user ocean terminals, and water terminal clearance authority responsibilities in CONUS and those oversea areas designated by DOD. Passenger traffic management support for defense passenger traffic within CONUS is also directed. It is within the mission of MTMC to provide transportation planning support to the organization of the JCS, the unified and specified commands, the military services, and the DOD agencies in support of the plans of the JCS and unified and specified commands, and other military operations as required. In support of the OPLANs of the unified/specified commands, MTMC:

(a) Prepares plans and provides, in coordination with MAC and MSC, for the CONUS movement of preplanned supply increments identified in each OPLAN from supply source to outloading (air/water) terminals for transshipment to oversea destinations.

(b) Selects CONUS outloading ocean terminals and determines CONUS terminal arrival date (CTAD) for each planned supply increment identified in each OPLAN. (Preelection of CONUS air/water terminals for each AMC/DLA/GSA supply facility are indicated in the AMC LP&P.)

(c) Effects maximum consolidation of planned supply shipments for outloading at CONUS (air/water) terminals to meet prescribed oversea terminal arrival dates (OTAD).

(2) Military Traffic Management Command Mobility Analysis and Planning Systems (MAPS).

MAPS II is the MTMC automated capability to support JOPS actions and OPLAN requirements, including the preparation of movement tables. The system designates the CONUS seaports and schedules movements requiring commercial transportation from CONUS departure locations to air and sea TOEs. MAPS II consists of several interactive modules which identify requirements, determine commercial transportation to meet requirements, selects ports, schedules movements from points of origin to outload ports on CONUS destinations, analyzes capabilities of transportation system and produces movement tables and management reports.

(a) Extract Module—Identifies MTMC requirements out of the total OPLAN TPFDD requirements and creates a MAPS II data base including only those requirements.

(b) Quick Analysis and Aggregation Module—Produces management reports that enables MTMC to do front end analysis and tailor transportation networks.

(c) Scheduler Pre-Processor Module—Establishes transportation networks based on movement requirements and parameters provided by MTMC planners.

(d) Scheduler Module—Schedules requirements over the established networks based on criteria established in the OPLAN TPFDD and numerous MAPS II unique parameter files.

(e) Report Generator Module—Produces hard copy movement tables and numerous management reports that enables MTMC to analyze the transportation feasibility of the CONUS movements of the overall OPLAN.

b. Military Airlift Command. MAC is chartered by DODI 5160.2 and is composed of controlled transport aircraft together with personnel, facilities, and equipment necessary to support the operation. Not included in MAC are transport aircraft whose design or configuration limits their employment to specialized tasks, those required by the military departments for administrative airlift service or combat readiness training, and those whose assignment outside of the agency is required by overriding military considerations. MAC airlift responsibilities include strategic airlift for long-range deployment of military forces and management of tactical airlift within a theater of operations. Included in the general functions of MAC are those to:

(1) Provide airlift transportation planning support to the organization of the JCS, the unified and specified commands, the military services, and

the DOD agencies in support of the plans of the JCS and other military operations as required.

(2) Provide airlift service support to include intra and inter theater aeromedical evacuation to DOD components as required.

(3) Develop plans to ensure the efficient use and control of military-owned and commercial air transportation resources and capabilities made available to the DOD under mobilization or other emergency conditions other than LOGAIR/QUICKTRANS.

(4) Prepare long and short-range forecasts of airlift requirements based on evaluated requirements submitted by the DOD components and match these with airlift capabilities. In accordance with procedures established by the OJCS, submit requirements and capabilities to the OJCS together with recommendations as appropriate to ensure a proper balance.

(5) Develop, establish, and operate an integrated transportation information data system to support the mission of the agency.

(6) In support of JOPS, the MAC Integrated Military Airlift Planning System (IMAPS) is the MAC automated capability for development of airlift plans. The system considers planning variables such as latest arrival date, availability of aircraft and crews, the most expeditious and efficient routing, and enroute staging or refueling bases. It consists of three subsystems: Airlift Requirement Collector (ARC), Flow Generator (FLOGEN), and Reports Generator (REPGEN) which sequentially gather the airlift requirements, schedule missions, and generate user reports. IMAPS is operated and maintained by MAC on the WWMCCS computer and uses airlift assets prescribed by the JCS as being available for planning. During execution planning, airlift assets and availability are modified to reflect the current situation.

c. Military Sealift Command.

(1) MSC is chartered by DODI 5160.10 and is the single manager for ocean transportation conducted between points in the CONUS and overseas areas, between and within overseas areas, and in intercostal service within the CONUS and those additional functions specifically assigned by the Secretary of Defense.

(2) Included in the general functions of MSC are those to:

(a) Provide, within the mission of MSC, ocean transportation planning support to the organization of the JCS, the unified and specified commands, the military services, and the DOD agencies in support of the plans of the JCS and other military operations as required.

(b) Provide ocean transportation support to the DOD components as required.

(c) Develop plans to ensure the efficient use and control of military-owned and commercial ocean transportation resources and capabilities made available to the DOD mobilization or other emergency conditions.

(d) Based on evaluated requirements submitted by the DOD components, prepare long- and short-range forecasts of sealift requirements and match them with sealift capabilities. In accordance with procedures established by the OJCS, submit requirements and capabilities to the OJCS together with recommendations as appropriate to ensure a proper balance.

(e) Develop, establish, and operate an integrated transportation information data system to support the mission of the agency.

(3) MSC Strategic Sealift Capability Planning System (SEACOP) provides MSC with computerized methods for determining the shipping resources needed to meet the cargo, troop, and POL sealift requirements for OPLAN development. The system uses a predetermined ship data base, port characteristics data, and planning assumptions to determine number and types of ships required to provide feasibility to the sealift requirement of the OPLAN. SEACOP consists of several subsystems which determine MSC sealift requirements, provide port characteristics data, estimates ship availability at POEs, computes distances between ports, test sealift feasibility, and produces required output reports.

(a) The Requirements Preparation Subsystem-Isolates MSC sealift requirements.

(b) The Ports Subsystem-Provides port characteristics data.

(c) The Requirements Aggregation Subsystem-Extracts data from JOPSREP.

(d) The Ship Availability Subsystem-Estimates time required for ships to become available at POEs.

(e) The Distance Subsystem-Computes distances between pick up and delivery ports.

(f) The Gross Feasibility Subsystem-Compares sealift requirements and lift capacity of MSC-controlled ships.

(g) The Quacing Subsystem-Simulates performance of delivery port based on berths available and daily throughput limit.

(h) The Scheduler Subsystem-Performs sealift feasibility testing using output of other subsystems.

(i) The Retrieve Subsystem-Produces required output reports.

(j) The Message Assembly Subsystem-Transfers card-formatted tape from system to AUTODIN.

(4) During normal planning, MSC uses the JOPS III files for ship availability data. During execution planning, sealift data is modified to reflect the current situation.

6-18. Host Nation Support (HNS)

The objective is to use HNS as much as possible based upon the reasonable assurance that host nation resources will be available. HNS, where appropriate, is the preferred means to meet support requirements. Where HNS is impractical, Reserve Component (RC) units may be programmed to satisfy the requirement when projected readiness levels indicate that RC units could be expected to meet the necessary deployment schedule. If neither HNS or RC unit support is feasible, program additional active support units against the requirement, within projected resources.

CHAPTER 7

THE US ARMY MATERIEL COMMAND (AMC) ROLE IN LOGISTICS PLANNING

Section I. GENERAL

7-1. Introduction

a. The commanders of unified commands (figure 7-1) are charged with the responsibility to prepare contingency plans to meet situations that may arise within their areas of operations. Some plans may require additional forces from outside the theater. Almost all will require additional logistical support, especially supply support. For the US Army component command of the unified command and the US Army elements outside the unified command that are required to implement the operation plan (OPLAN), the supply support will most probably come from Continental United States (CONUS) supply agencies. The responsibility in CONUS to provide supply support for US Army forces overseas is divided among several Department of the Army (DA) major commands, the Defense Logistics Agency (DLA), General Services Administration (GSA), and other military services. The movement of these supplies involves several transportation agencies. To coordinate the arrangements for planned supply support (not including accompanying supplies and medical supplies), the Commander, AMC has been designated the DA coordinating authority and single point of contact for all supplying commands and agencies for arranging this support. Thus, the supported command and all the supporting commands who provide augmentation to support unified command OPLANs have interface with HQ, AMC, its subor-

dinate commands, separate installations, and activities. The AMC Logistics Policies and Procedures (AMC LP&P) for Contingency Planning delineates responsibilities for the preparation and execution of the AMC Logistics Plan (LOGPLAN). In HQ, AMC, the Deputy Chief of Staff for Readiness (AMCRE) is the principal staff element for development, coordination, and preparation of the AMC LOGPLAN to support the approved OPLANs of US Army component commands of unified commands. Other directorates provide guidance, assistance, and other input within their areas of functional interest to the AMCRE in the development of each AMC LOGPLAN based upon review, analysis, and evaluation of the subordinate commanders' estimates and guidance from higher headquarters, DA, or the supported Commander in Chief (CINC). Commanders of AMC subordinate commands, agencies, and offices have specific responsibilities for support of each OPLAN. These responsibilities are based on principal missions assigned to a particular subordinate organization. Each AMC subordinate commander assigned an OPLAN mission provides to Commander, AMC, an estimate of his capability to support the OPLAN. The Commander, AMC, then prepares his estimate of support capability which becomes the basis for the AMC LOGPLAN. The Surgeon General (TSG) also provides his plans for incorporation in the AMC LOGPLAN.

UNIFIED/SUB-UNIFIED COMMANDS	ARMY COMPONENT COMMANDS AND OTHER MAJOR ARMY COMMANDS
Readiness Command (REDCOM)	US Army Readiness Command ¹ (USARRED) 172d Infantry Brigade
Atlantic Command (LANTCOM)	US Army Atlantic Command ¹ (USARLANT)
Southern Command (USSOUTHCOM)	193d Infantry Brigade ¹
European Command (EUCOM)	US Army Europe (USAREUR)
Central Command (CENTCOM)	US Army Forces Central Command (USARCENT) Third US Army
Pacific Command (PACOM)	US Army Western Command (WESTCOM)
Commander, US Forces Korea ² (COMUSKOREA)	Eighth US Army (EUSA)
Commander, US Forces Japan ² (COMUSJAPAN)	US Army Japan (USARJ)

NOTES:

1 Army units which are assigned to these commands belong to US Army Forces Command

2 Sub-unified command of PACOM

Figure 7-1. Unified commands and designated Army commands.

b. AMC is also responsible for:

- (1) Providing logistics data to TSG.
- (2) Incorporating into AMC plans, TSG support plans.
- (3) Preparing transportation movement requirements data (TMRD), and providing these data to Joint Deployment Agency, supported CINC and MTMC.
- (4) Providing materiel status data to DA and, as appropriate, to others.
- (5) Operating Service Item Control Centers (SICC) (AR 710-1) for DLA/GSA and other military services materiel (less medical and general-

purpose automatic data processing equipment (ADPE)) for computation of contingency, mobilization, and prepositioned war reserve materiel stocks (PWRMS) (AR 11-11). TSG operates the SICC for medical materiel.

(6) Providing installation support, training, and development to units mobilized at AMC subordinate commands.

c. AMC provides supply support to the theater-based forces of the Army component of the supported command, the Army component of the augmentation forces of the supporting commands being deployed from CONUS or another theater,

and such support for allied forces as directed. In coordination with the Army component being supported and based on the Army component commander's (ARCOM) OPLAN, AMC develops a Logistics Support Plan which provides for delivery of specific items of supply to required locations at required times for specified units. The AMC LOGPLAN spells out in detail the concept of how support is to be provided, the identity of the troops being supported at specific locations, what and how much support they will receive, when they will receive it, the schedules, and other transportation data for shipment of supplies from various points of origin through intermediate points and outshipping terminals to arrive at overseas destinations to insure continuous support. This is a complex planning process which requires careful coordination between HQ, AMC, its participating commands and agencies, TSG, Army Information Systems Commands (AISC), Army Intelligence and Security Command (INSCOM), DLA, GSA, the TOAs, other services and agencies providing support, and the commands being supported.

d. Supplying activities cannot rely solely on the CONUS industrial base to respond effectively to all the requirements placed on it at the time an OPLAN is implemented. For this reason, the Department of Defense (DOD) in DODD 4140.2 provides guidance for the establishment and management of a positive and continuing war reserve program. These stocks are established in overseas locations and CONUS. The various types of war reserve stocks (WRS) are defined in section III, chapter 3. Initial support will be provided from these WRS. The planned operations may occur in an area with an established US logistics base or in an area in which no US logistics base exists.

(1) In an area with an established logistics base, initial supply support for theater based forces is provided from available theater reserve and project stocks until preplanned supply support from CONUS sources becomes available. For CONUS forces deployed to augment theater-based forces, initial supply support is provided by a combination of accompanying supplies, project stocks, PWRMS, and preplanned resupply support on a time-phased basis for a specific period.

(a) The purpose of supplies accompanying deploying units is to fill the void of logistics support until the pipeline has been established. The supported commander will dictate the number of days and composition of accompanying supplies in his planning guidance.

(b) Initial preplanned supply support (IPSS) consists of standardized procedures to identify, locate, prioritize, and preplan the shipment of crit-

ical materials of Class III (bulk fuel), Class V, and Class VII that must begin moving during the first 15 days after the implementation of OPLANS/LOGPLANS. Supported Army component commanders may include other classes of supply as necessary. IPSS uses prepositioned requisitions and preplanned supply increments to be called forward as required by the supported Army component commander. IPSS is not intended to supersede any reporting or materiel requisitioning systems already in effect; however in the deliberate planning cycle, IPSS reflects the best estimates of requirements to support the force. Additionally, IPSS will address sustaining supplies for those items not already prepositioned (i.e., PWRMS shortages, operational project stocks, decrement stock shortages) for the first 30 days in support of an OPLAN designated by the JCS.

(c) Preplanned supply is the providing of those supplies necessary to sustain a force for a specified period (usually until normal supply procedures can be implemented), less accompanying supplies. It is a function of the AMC major subordinate commands and SICCs (except conventional class V and class VII) to compute preplanned supply requirements based on appropriate planning factors. The US Army Depot System Command (DESCOM) computes preplanned supply for conventional class V and class VII. Wartime Active Replacement Factors (WARF) for petroleum, ammunition and equipment are the responsibility of the DCSOPS. They are developed by the Concepts Analysis Agency through the use of wargaming simulations. WARF is a set of daily combat consumption factors for each day deployed in a given combat theater in order to develop combat consumption requirements as a portion of the Army Acquisition Objective (AAO).

(d) Supply buildup is designed to provide sources of supply should, for some reason, the resupply pipeline to the objective area be interrupted. It is a specified quantity in terms of days of supply to be positioned within a stated period of time, as outlined in guidance by the supported commander.

(2) Supply support for an operation planned for an area in which no logistics base exists, and for which all troops employed must come from outside the area, is provided through a combination of accompanying supplies and preplanned resupply support. Initial supplies are provided from CONUS sources and/or theater stocks prepositioned for contingency operations. Preplanned resupply support is on a time-phased basis for a designated period.

(3) In either type contingency, as the supply situation stabilizes and demand experience is gained along with knowledge of what is on hand and what is due in, adjustments to the authorized

stockage list (ASL) will be made. Maximum utilization of airlift will be made to satisfy critical shortages and for emergency requirements.

Section II. AMC LOGPLAN DEVELOPMENT

7-2. Planning Responsibilities Within AMC

Responsibilities, policies, and procedures for the development of AMC LOGPLANS to support OPLANS of Army component commands are contained in the AMC LP&P for Contingency Planning.

a. Responsibilities of staff offices, HQ, AMC in support of OPLANS.

(1) AMCRE is the principal staff element in HQ, AMC for the development, coordination, and preparation of the AMC LOGPLAN to support approved OPLANS of Army component commands of unified commands. Other important tasks include:

(a) Arranging the troop list for each approved OPLAN in relative priority or arrival by transportation mode for a specific destination.

(b) Monitoring the Joint Operations Planning Systems Report (JOPSREP) and the preparation and submission of TMRD.

(c) Staff supervision for coordinating AMC storage of US Army Forces Command (FORSCOM) units' basic loads.

(d) Staff supervision of logistics assistance of support activities in CONUS and overseas, including development of personnel requirements for logistics assistance and liaison activities.

(e) Coordinating the scheduling of shipments of base development materiel.

(f) Coordinating logistics assistance and liaison requirements.

(g) Monitoring actions affecting AMC/Theater Army/Theater Army Areas Command (TAACOM)/Corps Support Command (COSCOM)/Materiel Management Center (MMC) interface during various phases of the LOGPLAN.

(h) Developing and disseminating notification of the alert phase or execution phase of each LOGPLAN.

(i) Preparing in coordination with AMC staff elements, the AMC assessment of capability and readiness to support each supported OPLAN.

(j) Activate AMC Operations Center upon receipt of notification to execute OPLAN.

(2) The Deputy Chief of Staff for Supply, Maintenance, and Transportation (AMCSM) is the principal staff element for distribution, maintenance, documentation, and transportation matters relating to all AMC LOGPLANS. AMCSM also:

(a) Exercises staff supervision over the Army Master Data File (AMDF).

(b) Develops phased preplanned supply schedules for each approved OPLAN.

(c) Coordinates the criteria for computation of preplanned supply requirements and pre-positioned emergency supply requirements, based on logistics guidance in plans of supported commands.

(d) Prepares and submits order of magnitude cost estimates for depot handling costs and second-destination costs for each LOGPLAN.

(e) Exercises staff supervision over National Maintenance Points (NMP) except Army Medical Department (AMEDD) NMP, and AMC activities such as DESCOM and the US Army Materiel Readiness Support Activity (MRSA) in developing and implementing maintenance plans, policies, and concepts.

(f) Provides maintenance priorities to AMC major subordinate commands and depots.

(g) Develops and submits funding requirements for depot maintenance.

(h) Develops the maintenance portions of the estimate of the AMC capability and readiness posture.

(i) Administers base development materiel in specified operational projects.

(j) Exercises staff supervision over required documentation (AMDF, computed requirements, shipment status) for the AMC/Theater Army/TAACOM/COSCOM/Task Force MMC interface.

(k) Develops and submits, in coordination with AMC Deputy Chief of Staff for Resource Management, requests for additional program authority for Army Stock Fund (ASF) and other funds.

(l) Reviews, analyzes, and evaluates estimates for funds submitted by AMC major subordinate commands and depots.

(m) Prepares the distribution and transportation estimate of the AMC capability and readiness to support an AMC LOGPLAN.

(n) Ascertains and disseminates required Military Standard Requisitioning and Issue Procedures (MILSTRIP) data to effect release of supply documentation in support of the executed AMC LOGPLAN.

(3) The principal responsibilities of the Deputy Chief of Staff for Production (AMCPD) include the development of policies and procedures relating to materiel production and acquisition objectives. AMCPD also:

(a) Serves as the principal staff element for maintaining the status of program releases for authorized quantities of Procurement Appropriation, Army (PAA) major items.

(b) Prepares and submits order-of-magnitude cost estimates for materiel required and prepares

requests for additional program authority and funds for materiel end items.

(c) Develops the materiel requirements and acquisition portions of the AMC capability and readiness position.

(4) The Deputy Chief of Staff for Resource Management (AMCRM) is responsible for all aspects of financial management, to include disseminating Fund Codes, programming, budgeting, funding, cost accounting, and reporting for each LOGPLAN and for developing the financial estimate of AMC capability and readiness. The AMCRM is also responsible for the personnel management aspect of the AMC LOGPLAN to include development of the personnel estimate of the AMC capability and readiness to support the LOGPLAN.

b. Responsibilities of AMC major subordinate commands and SICCs. (AMC major subordinate commands and TSG commodity manager are shown in figure 7-2.)

US Army Armament, Munitions and Chemical Command--AMCCOM

US Army Communications-Electronics Command--CECOM and subordinate activities.

US Army Electronic Materiel Readiness Activity--EMRA.

US ARMY Tank-Automotive Command--TACOM.

US ARMY Aviation Systems Command--AVSCOM

US ARMY Missile Command--MICOM.

US ARMY Laboratory Command--LABCOM

US ARMY Troop Support Command--TROSCOM
and designated Service Item Control Centers:

US Army General Materiel and Petroleum Activity--GMPA.

US Army Support Activity--USASA.

US Army Materiel Command-Europe--USAMC-E.

US Army Medical Materiel Agency--USAMMA. *

(*The DA Surgeon General's Activity.)

Figure 7-2. AMC Major Subordinate Commands.

(1) Provide materiel for which they have management responsibility to support forces identified in each AMC LOGPLAN.

(2) Based on troop strength, Equipment Requirements Data/Equipment Density Data, supply schedule guidance, and prescribed computation criteria, they compute preplanned supply requirements (except conventional class V and class VII which are computed by DESCOM) for US forces

designated in the OPLAN, and submit them to designated COSCOM/TAACOM units as required.

(3) Prepare and maintain supply documentation for computed supply requirements and civil engineering support materiel requirements for each OPLAN.

(4) Prepare a schedule for release of supply documentation to supply sources to meet the assigned CONUS Terminal Arrival Date (CTAD) for

each increment of supply in support of an AMC LOGPLAN.

(5) Prepare and provide, to applicable depots, depot supply support requirements data.

(6) Prepare JOPSREP or TMRD for each shipment of Army and DLA/GSA planned supply. Transmit all TMRDs to AMC and the Logistics System Support Activity (LSSA).

(7) Provide logistics assistance and liaison personnel as directed.

(8) Prepare and submit order-of-magnitude cost estimates, requests for additional funds, and reports of actual costs incurred in support of each OPLAN.

(9) Prepare plans to expand the military/civilian work force and operational capability as required to support each LOGPLAN.

(10) Provide disposition instructions to deployed/employed forces for reported excess materiel.

(11) In addition to the above, the US Army Armaments, Munition and Chemical Command (AMCCOM) and US Army Missile Command (MICOM) must arrange for storing, maintaining, and shipping basic loads of ammunition that FORSCOM units must store in AMC facilities.

(12) It should also be noted that DOD has assigned the mission of conventional ammunition procurement, production, supply maintenance, and transportation to DA. The execution of that mission has been assigned by DA to AMC who has redelegate the management to AMCCOM.

c. AMC depots:

(1) When designated as area-oriented depots (AOD), a Consolidation/Containerization Point (CCP) or distribution depots for major items, develop plans and procedures to execute missions and functions of such activities.

(2) Develop shipment plans to control and monitor documentation and materiel release throughout the depot supply and transportation cycle.

(3) Insure adequate levels of protection, marking, and packaging of supply shipments are accomplished.

(4) Prepare and submit estimates of additional funds required and reports of actual costs incurred to support a LOGPLAN.

(5) Develop plans to expand operational capability and work force to support the LOGPLAN.

(6) Develop the commander's estimate of capability and readiness to support a LOGPLAN.

d. All activities are responsible for the preparation and submission of additional funds required

and for reporting actual costs incurred to support an OPLAN. Each activity must plan for the necessary expansion of its work force to support various OPLANS. In addition, each activity must submit reports required during the alert and execution phases of each OPLAN. Responsibilities peculiar to various activities in support of each OPLAN are:

(1) DESCOM extracts from the DA Structure and Composition System (SACS) File, obtained from the Deputy Chief of Staff for Operations and Plans (DCSOPS), DA, the Tables of Organization and Equipment (TOE) /Modification Tables of Organization and Equipment (MTOE)/Tables of Distribution and Allowances (TDA)/Military Airlift Command (MAC) Transportation Authorization (MTA) for troop units listed. Based on these authorizations, the US Army Management Systems Support Agency (USAMSSA) Standard Requirement Code (SRC) File, and unit asset reports (AR 710-3), DESCOM consolidates and disseminates stratified equipment requirements data/equipment density data (quantities, make, model, and type) to AMC elements and other designated addresses, including the MMC of the COSCOM. DESCOM computes conventional class V and class VII planned supply requirements, based on troop strengths, weapons and weapon systems equipment readiness date (ERD)/estimated delivery date (EDD), the level of prescribed maintenance and resupply requirements criteria.

(2) The Anniston Army Depot prepares and maintains, in serviceable condition, the prescribed emergency supply packages in a rigged, ready-for-airdrop configuration.

(3) The US Army Materiel Command Logistics Control Activity (LCA), upon OPLAN execution, will utilize the Logistics Intelligence File (LIF) to receive, maintain, and coordinate AMC LOGPLAN documentation as well as serve as the Army control point to monitor all supply and transportation support aspects, including the flow of data between CONUS supply sources and the supported Theater Army/TAACOM/COSCOM MMC. The LCA also acts as the Army airlift clearance authority and arranges special assignment airlift missions (SAAMs).

(4) MRSA, in coordination with appropriate staff offices of HQ, AMC, provides assistance as needed for logistics assistance and liaison activities.

(5) The LSSA configures and disseminates JOPSREP troop lists in prescribed format and receives, summarizes, validates, maintains, and disseminates JOPSREP TMRD received from Nation-

al Inventory Control Point (NICP)/SICC and TSG. The LSSA also prepares and distributes complete movement table data and abbreviated movement table data (extracts of non-unit related cargo data and TDA's movement. Table data (L, M, N, P) in accordance with Appendix T to the AMC LP&P.

(6) The US Army AMC Catalog Data Activity (USACDA) provides a complete AMDF to the supported Theater Army/TAACOM/COSCOM MMC.

7-3. AMC Planning Cycle

a. The Commander, AMC is charged with the responsibility for preparing plans to provide logistics support for each approved OPLAN of the Army component and major Army commands (MACOM) of theater-based forces and the OPLANs of Army component and major commands of supporting forces being deployed from CONUS or other theaters to augment in-theater forces. These plans include support for other US forces and allied forces as required. AMC enters the planning sequence upon receipt of approved OPLANs of the supported and supporting unified commands, their Army components, and/or planning agents. This is depicted in figure 5-6 as the supporting plans process. However, AMC may be called upon to have representatives (usually military planners from the Deputy Chief of Staff for Readiness) attend planning conferences early in the Plan Development Phase (step 2, Support Planning, figure 5-5, chapter 5) or to provide advice and assistance to the supported Army component planners.

b. The plans of the Army component commanders of the supported and supporting unified commands should contain sufficient information (size, composition, time-phased schedule for deployment, employment, and concept of support of required forces) (see paragraphs 6-9 and 6-10, chapter 6) to permit development of plans by designated planning agents and other supporting commands and agencies. For the plans of the supported commander to contain all of the necessary elements as described in paragraph 6-10, chapter 6, the component commanders, supporting commander, and the TOAs should get involved in step 2, Support Planning of the Plan Development Phase (figure 5-5, chapter 5). AMC should also be brought into the picture at this time. The forces considered in the plan development process are notional forces, and movement data for personnel, equipment, and accompanying supplies, and that of the resupply requirements are computed on the basis of those notional organizations. Army combat divisions and their maneuver battalions are unique within their organization. The personnel strengths, composition, equipment, and population of one infantry

division may be different from that of another infantry division. Even within the division, similar maneuver battalions may differ in size and equipment. For this reason, AMC commodity managers must know the identity of each Army unit to be supported so they can determine how much of what types of supplies are required. This is especially true of classes III, V, VII, and IX supplies. The points of origin for the supply and resupply items may also be significantly different, which could seriously impact on movement tables developed by the TOAs. The result of planning on the basis of notional units and theoretical points of origin may be the inability to move actual deploying forces within the time frames planned. In short, AMC needs Unit Identification Code (UIC) not Unit Type Code (UTC) information.

c. The OPLANs of the supported and supporting Army components and/or MACOMs include the necessary information upon which other supporting commands and agencies can develop their plans for support of the unified commander's OPLAN. The supporting commands' OPLANs are provided to the supported CINC and component assigned commands so these commanders know how they are to be supported and who will be providing the support. AMC and its subordinate commands as well as the transportation commands and designated planning agents, can initiate some advance planning upon receipt of the approved plans of the supported unified commander and the Army component command commander. Upon receipt of the supporting CINC plan (Readiness Command (REDCOM), other CINCs), the supporting Army component or designated planning agent develops supporting plans, obtains approval from the CINC responsible for conducting the operation or, if appropriate, coordinates with the supported CINC and then sends the plans to AMC and other commands who prepare their supporting plans.

d. AMC, using the plans of Army component commands and the planning agent, develops a detailed logistics support plan. This plan includes the logistics support concept, troop lists, preplanned resupply schedules, support requirements for prisoners of war (PW), civil relief, allied forces, and common item support for other US forces. This plan is coordinated or approved by the planning agent of the supported Army component, and has to be furnished to AMC subordinate commands and other supporting commands and agencies (DLA, GSA, TSG, MAC, Military Sealift Command (MSC), and Military Traffic Management Command (MTMC)) to prepare their supporting plans.

e. AMC planning procedures:

(1) Upon receipt of OPLANs of the commands to be supported, AMC (Deputy Chief of Staff for Readiness) develops a detailed logistics support plan which delineates the logistics support concept, troop list, supply schedules, logistics support requirements, and TMRD. This plan is coordinated with the supported commands and other supporting commands (DLA, GSA, TSG, TOAs). TSG develops a detailed plan to provide medical supply support. This plan is included in the AMC LOGPLAN. TSG also develops JOPSREP nonunit related cargo data for those supply items managed by TSG.

(2) As appropriate, Army component commanders, using automated procedures prescribed by JCS Pub. 6, vol. II, Part II, Joint Operation Planning System or by manual means, develop

Time Phased Force Deployment Lists (TPFDL) which designate specific units for each OPLAN to accomplish assigned contingency operation missions. AMC (DCS for Readiness), upon receipt of approved TPFDL, perpetuates selected data elements for each unit listed and arranges the units in priority of arrival in the objective area at specific destinations by transportation mode. For JOPSREP TPFDL, the DCS for Readiness requests AMC LSSA to activate AMC JOPSREP procedures and to extract selected data elements from the TPFDL of the Army Components' OPLAN and to develop a TPFDL in the prescribed format (see Figure 7-3). These lists are furnished to the DCS for Readiness, HQ, AMC for inclusion in the AMC LOGPLAN and to AMC DESCOM for development of ERD/EDD. Guidance for developing the ERD/EDD is provided to DESCOM by DCS for Readiness, HQ, AMC.

COORDINATED PREPLANNED SUPPLY

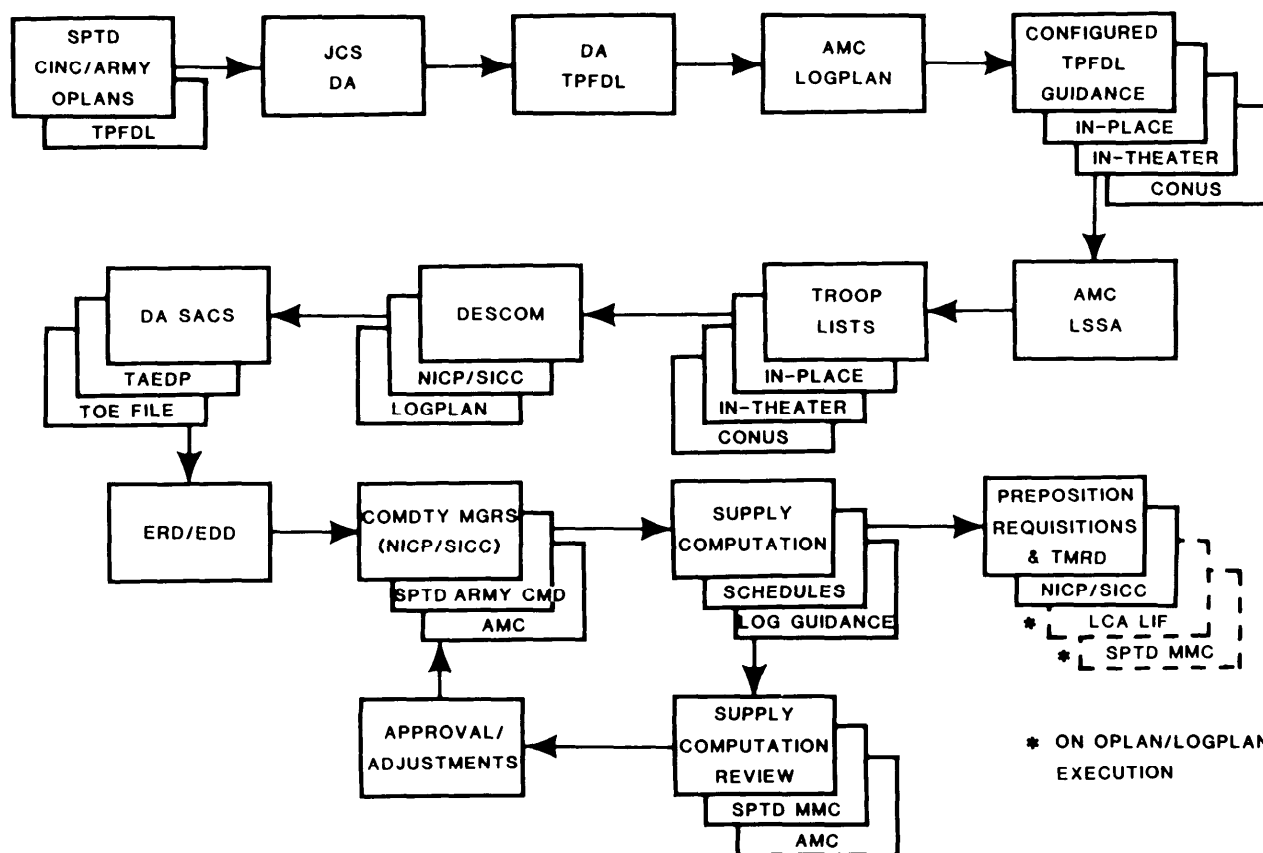

Figure 7-3. AMC Planning Functions-JOPSREP force and equipments determination.

(3) AMC, on the basis of these troop lists and in coordination with the applicable supported Army component command and/or its designated

planning agent, develops a phased preplanned re-supply schedule for each supported OPLAN. These schedules become Annex B to the AMC LOG-

FM 701-58

PLAN. Each supply schedule will include project code, class of supply, days of supply per project code or shipment, supported strength by time phase, CTAD when supply shipments are required for out-loading expressed in C/D day, overseas terminal arrival date (OTAD) when supplies are required at the overseas terminal expressed in C/D-day and any explanatory remarks. Depending on OPLAN guidance, supply schedules may be required for:

(a) Support of US forces:

1 Based in theater.

2 Based in CONUS or other areas, designated for augmentation.

3 Deployed to staging/marshalling areas while awaiting D-day.

4 Employed in each objective area.

(b) Support of allied forces employed in each objective area.

(c) Support of guerilla forces.

(d) Support of PWs.

(e) Support of civil relief operations.

(f) Shipment of operational project stocks stored in AMC facilities, to include a detailed bill of materiel, by timeframe.

(g) Civil engineering support materiel, to include a detailed bill of materiel by timeframe.

(4) From these troop lists, data from unit TOE/MTOE, TDA/Modification TDA (MTDA), DA SACS File, AR 710-3 stock status reports, FORSCOM for fragmented units, and other source documents, AMC (DESCOM) develops stratified ERD/EDD listings which are provided to NICPs/SICCs and other commands for use in computing time-phased preplanned resupply requirements.

(5) AMC subordinate commands, using the ERD/EDD provided by DESCOM, compute the supply requirements (except conventional class V and class VII items), preposition supply requirements, and supply documentation with appropriate activities; e.g., NICP/SICC, LCA, MMC of supported Army command, and other activities as directed. Computed requirements are reviewed by appropriate AMC subordinate commands, who also prepare and preposition the supply documentation.

(6) After computing the requirements and prepositioning the documentation, the NICP/SICC create the JOPSREP nonunit related cargo data or manual TMRDs which are sent to AMC LSSA to be reviewed, corrected, validated, and then merged with TMRD submissions of all AMC supplier activities and TSG, DLA, and GSA. (See figure 7-4.)

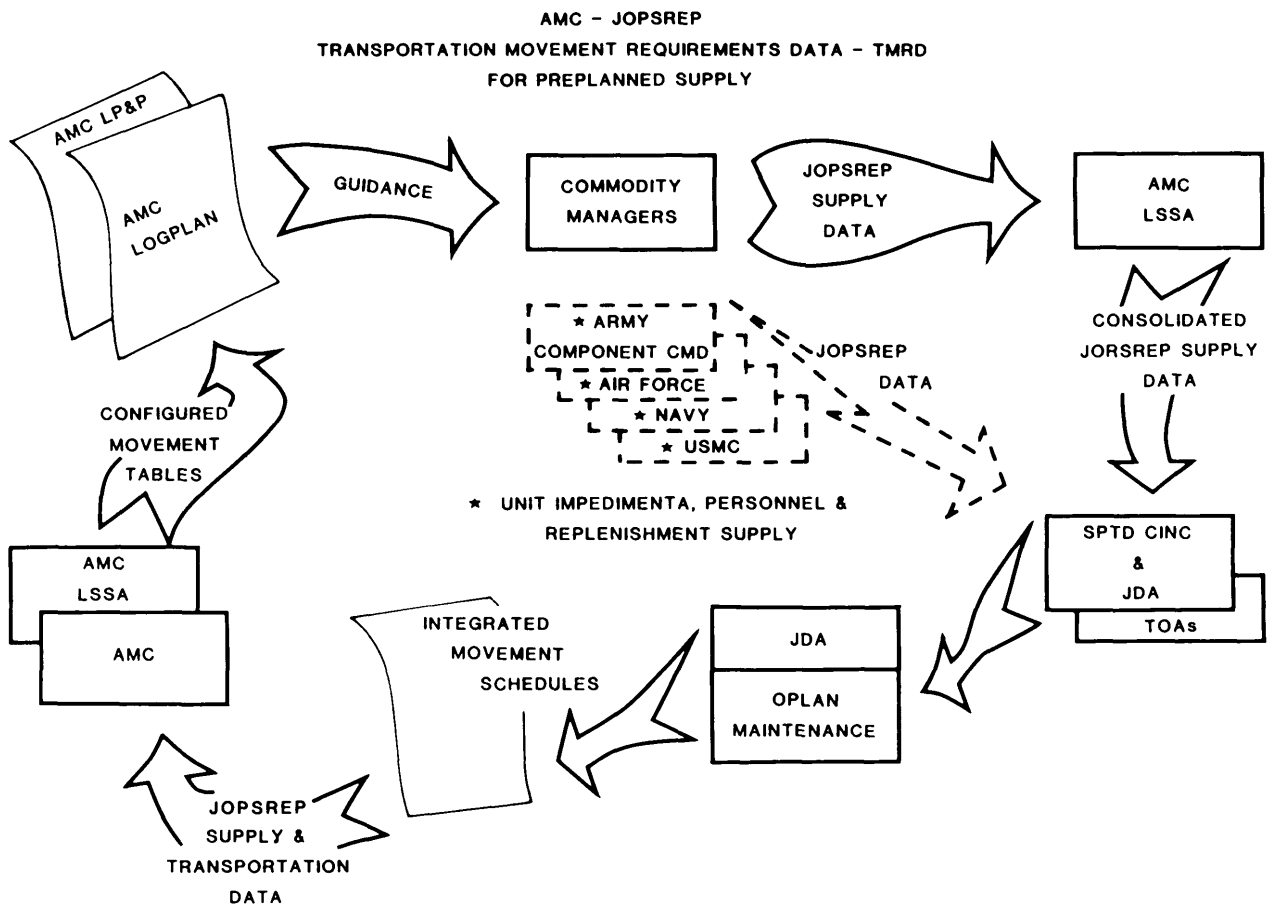

Figure 7-4. AMC TMRD for preplanned supplies.

(7) The TOAs, by direction of the supported commander and using TMRD provided by various component commands for force movements and the service logistics agencies and commands for supply movements, develop preliminary movement tables and provide these tables and identified shortfalls to the supported commander for resolution.

(8) The supported commander convenes a transportation coordination conference, attended by representatives of the supported and supporting commands, service component commands, services

and major logistics commands, and TOAs, to resolve the shortfalls and constraints and develop the final integrated transportation movement tables. These tables are distributed to interested headquarters, commands, and agencies.

(9) The Army component of the supported command provides to Army supporting commands that portion of the integrated transportation plan pertaining to their areas of interest, to include JOPSREP L, M, N, and P records. AMC (LSSA), upon receipt of its portion of the plan, prepares abbreviated movement tables (extracted data from L, M, N, and P records as shown in figure 7-5).

DATA EXTRACTED FROM AMC/TSG NON-UNIT RELATED CARGO DATA (NRC)	1	
	2	
	3	
	4	CARGO INCREMENT NR - CIN
	5	
	6	
	7	
	8	
	9	ORIGIN (SUPPLY SOURCE)
	10	GEOLOC CODE
	11	
	12	SUPPLY CLASS/SUBCLASS
	13	
	14	
15		
16		
17	CARGO WEIGHT S/TONS	
18		
19		
20		
21	PROJECT CODE	
22		
23	ORIGINATOR - NICP/SICC CODE	
24	TRANSPORTATION LEG	
DATA EXTRACTED FROM MTMC "L" MOVEMENT DATA	25	DEPARTURE LOCATION TYPE CODE
	26	
	27	DEPARTURE DATE
	28	
	29	
	30	
	31	ARRIVAL GEOLOC CODE
	32	
	33	
	34	
35	ARRIVAL DATE	
36		
37		

DATA EXTRACTED FROM MAC OR MSC "M" - MOVEMENT DATA	38	TRANSPORTATION LEG
	39	DEPARTURE LOC TYPE CODE
	40	
	41	DEPARTURE DATE
	42	
	43	
	44	
	45	ARRIVAL GEOLOC CODE
	46	
	47	
DATA EXTRACTED FROM MAC OR MSC "N" - MOVEMENT DATA	48	
	49	ARRIVAL DATE
	50	
	51	
	52	TRANSPORTATION LEG
	53	DEPARTURE LOC TYPE CODE
	54	
	55	DEPARTURE DATE
	56	
	57	
DATA EXTRACTED FROM SPTD CINC "P" - MOVEMENT DATA	58	ARRIVAL GEOLOC CODE
	59	
	60	
	61	
	62	ARRIVAL DATE
	63	
	64	
	65	
	66	TRANSPORTATION LEG
	67	DEPARTURE LOC TYPE CODE
68		
69	DEPARTURE DATE	
70		
71		
72		
73	ARRIVAL GEOLOC CODE	
74		
75		
76		
77	ARRIVAL DATE	
78		
79		
NRC	80	CARGO PROVIDING ORGN
NRC	81	CGO PRV ORGN (SHORTFALL)

Figure 7-5. Abbreviated movement table format.

(10) The product of AMC planning is the commander's estimate of the capability and readiness to logistically support the contingency operations. This estimate developed by the Deputy Chief of Staff for Readiness, HQ, AMC from estimates received from AMC subordinate commands and depots which have been reviewed, analyzed, and evaluated by AMC staff offices.

f. For AMC to accomplish its planning mission, it must have some specific information. This information includes:

- (1) The troop list and size of force to be supported.
- (2) The amount of supply required by class of supply.
- (3) When supplies are needed by the supported force for all in place and deploying units, by force package identification.
- (4) Where the supplies are to be delivered.
- (5) What mode of transportation is to be used.
- (6) Civil relief support requirements.
- (7) PW support.

(8) Support required to be furnished allies. (For (6), (7), and (8), it is necessary to know who, what, when, where, and the level of support.)

(9) Categories of maintenance to be performed in the area of operations.

(10) Stockage objective.

(11) Identification of operational stocks stored in AMC depots to be used and replenishment of material used from oversea operational projects.

(12) Base development. (The bill of materials and schedule of shipments of construction equipment and materials derived from the list of items or facilities in each OPLAN is especially important.)

7-4. Logistics Support Policies

a. In addition to the specific guidance AMC derives from the Army component commander's OPLAN, the general instructions in the AMC LP&P provide the basis for subordinate commands to prepare their supporting plans.

(1) Logistics support for forces committed in contingency operations will be planned on an austere basis.

(2) The categories of maintenance to be performed in the area of operations must be consistent with the MTOE capability of units employed/deployed. Equipment (major end items, components, modules) requiring maintenance beyond the capabilities of maintenance support units are evacuated to CONUS or other designated facilities for repair or disposal.

(3) Commodity managers (AMC Major Subordinate Commands):

(a) Insure by examination, review, and analysis of computed requirements and in coordination with planning agents, that adequate repair parts and supplies are provided to maintain equipment in operation, particularly that equipment used continuously and that used under adverse conditions.

(b) Compute allowances for items costing \$10 or less on the basis of a minimum quantity of 10 each item or 180 days of supply, whichever is greater.

(c) Conduct engineering, professional, and technical review made of computer supply requirements to purify, increase, decrease, add, and/or delete quantities or items of supply to provide an adequate level of support with minimum items and quantities of supply, including constraints resulting from unit packs, economic order quantity, variable safety levels, and fringe items.

(d) Consolidate items as necessary to preclude uneconomical handling. Consolidation may

be made only within a given supply schedule, but not among or between schedules.

(4) Planned supply requirements for each supported OPLAN are computed on the basis of supported troop strength, equipment authorization and equipment density, and the level of maintenance to be performed in the objective area. Requirements will be limited to items authorized for issue in the climatic area/zone specified in the OPLAN.

(5) Replacement factors and consumption rates are computed as prescribed in appropriate Army regulations, supply bulletins, Common Tables of Allowance (CTA), technical manuals (TM), and AMC pamphlets or as modified for a specific OPLAN. Computed planned supply requirements for classes II, IV, VII, and IX items will be limited to those required for mission accomplishment and minimum necessary administration, housekeeping, and maintenance functions. For those items not provided in planned supply increments, the supported command will submit requisitions on a routine or emergency basis requesting delivery by air when appropriate to meet required delivery dates.

(6) For planning purposes, class I support of US forces consists of the following semiperishable standard rations and ration supplements.

(a) Meal, ready to eat (normally computed at a percentage prescribed by the supported command for a given strength and time period).

(b) Standard "B" ration (normally computed as prescribed by supported commander).

(c) Ration, long-range patrol (computed as prescribed by supported commander).

(d) Standard "B" hospital (BH) and hospital liquid (BHL) rations. (It is assumed that 70 percent of the total hospital patient strength will be subsisted on standard "B" ration. The remaining 30 percent of the patients will require modified diets, 15 percent requiring type "BH," and the other 15 percent requiring "BHL" rations) (SB 10-495-1 and SB 10-495-2).

(e) T Ration (computed as prescribed by supported commander).

(f) Ration supplement aid station (computed at .007 of supported strength per day per (SB 10-495-2).

(g) Ration supplement sundries pack (one pack per 100 individuals, per day if available) or the hygienic and comfort items prescribed in AR 700-23 will be provided in lieu of the sundries pack.

(h) Civil relief ration supplement (1,500 calories per day).

(i) PW ration (nutritional minimum established by TSG, DA).

(7) Unless otherwise specified, requirements for class III supplies are based on equipment density and equipment consumption factors; e.g., assumed daily mileage or hours of operation as stated in SB 700-2 for each item of petroleum, oils, and lubricant (POL) consuming equipment (wheeled vehicles, tracked vehicles, aircraft, water craft, generators, cooking ranges, etc.).

(8) Class V:

(a) The Commander, FORSCOM (FORSCOM Reg 700-3) and/or major oversea commander in coordination with Commander, TRADOC, provides guidance for computing class V basic loads. Deploying units compute basic loads and submit them through installation channels to HQ, FORSCOM for approval. When approved, the units requisition their basic load and arrange with the installation commander for their storage. Basic loads for FORSCOM units are stored at the unit/installation level within local storage and maintenance capabilities. Elements of the basic load that cannot be stored at the unit/installation are stored in those AMC facilities which can meet the required reaction time. Here they are prepared and processed for shipment in accordance with Military Standard Transportation and Movement Procedures (MILSTAMP) procedures, or as directed by the CDR, FORSCOM. Release and shipment of basic loads will be in a configuration to support either an administrative or tactical movement and will be stored by appropriate purpose codes in secondary item distribution mission depots, unless a depot is specified in the project or plan.

(b) Preplanned conventional class V requirements are computed by AMC (DESCOM) (reviewed and purified by AMCCOM and MICOM), based on EDD/ERD derived from weapons required/authorized by TOE/MTOE and on hand in units as shown in unit asset reports (AR 710-3), and war replacement factors specified by HQDA or as modified in the AMC LP&P.

(c) Selected missiles and toxic ammunition are generally not provided by preplanned supply unless specifically prescribed in the supported OPLAN. Units requiring these selected missiles must submit emergency requisitions for the items required.

(9) Class III:

(a) Computed planned supply requirements for class II are limited to expendable/consumable

items required for administration, housekeeping/janitorial, and maintenance functions; replacement batteries for electronic/signal equipment, automotive, and materials handling equipment (MHE); and telephone cable (wire).

(b) Replacement of individual clothing and equipment, tentage, tool sets and kits, hand tools, and office/administrative equipment is provided in preplanned supply increments only as required by the supported OPLAN and AMC LOGPLAN. This materiel/supply will be requisitioned by the supported command on a routine and/or emergency basis as required.

(10) Class IV:

(a) Limited to field fortification/barrier materiel, e.g., sand bags, concertina, barbed wire/pickets, etc., prescribed in each supported OPLAN. The supported OPLAN prescribes items and quantities required to be provided in preplanned supply increments.

(b) Requirements for base development materiel will be as prescribed in each supported OPLAN and applicable AMC LOGPLAN.

(11) Class VI: Personal demand items (nonmilitary sale items) are not provided by preplanned supply. In the early stages of an operation, hygienic and comfort items as authorized by AR 700-23 are provided gratuitously as part of class I supplies.

(12) Class VII: Major end items are not provided by preplanned supply unless specifically prescribed in the supported OPLAN. Units submit emergency requisitions for items required. When preplanned supply support is required, the supported OPLAN should identify specific requirements and quantities of end items for constituting repair cycle floats and replacement for attrition and combat losses.

(13) Class VIII: The stated troop strength in each OPLAN is the basis for computing medical materiel requirements. Medical supply is provided in accordance with phased supply schedules in each LOGPLAN and is issued from existing mobilization reserves (CONUS stocks) and unobligated peacetime stocks. Medical supplies consist of medical resupply sets, optical resupply items, civil affairs sets, and other medical unique materiel intended for patient care and treatment. (See chapter 9 of this manual or AR 40-61.)

(14) Preplanned supply for class IX items configured in multiples of 15 day increments (e.g., 15, 30, 45, 60 days) for shipment and is computed on the basis of EDD/ERD to be supported and level of maintenance to be performed in the theater. Re-

quirements computations will be based on supplying components and modules in the initial increments of supply rather than piece parts. Follow-on shipments will include piece parts required to rehabilitate direct exchange (DX) components generated during initial phases of operations. Subsequent shipments should contain a mix of components, modules, and piece parts.

(15) Class X materiel to support nonmilitary programs (e.g., agriculture and economic development projects) are considered part of civil affairs operations. Accordingly, supply of these items is not part of preplanned supply.

(16) Stocks in the wholesale supply system managed by AMC are positioned in accordance with the AMC Revised Distribution Plan.

(a) Stockage and issue of secondary items to support field activities worldwide will be limited to the AODs (New Cumberland, Red River, and Sharpe Army Depots).

(b) Secondary items required for operational projects or items in support of contingency plans are stored with the appropriate purpose codes at the depot currently specified in the project or plan. If no depot is specified in the project or plan, materiel are stored in the secondary item distribution mission depots.

(c) Secondary item distribution-storage assignments and support area assignments are:

1 Distribution-Storage Assignments.

<i>New Cumberland</i>	<i>Red River</i>	<i>Sharpe</i>
AMCCOM	AMCCOM	AMCCOM
TROSCOM	TROSCOM	TROSCOM
AVSCOM	AVSCOM	AVSCOM
MICOM	MICOM	MICOM
TACOM	TACOM	TACOM

2 Support Area Assignments.

<i>New Cumberland</i>	<i>Red River</i>	<i>Sharpe</i>
Europe	Tennessee	Pacific
Puerto Rico	Kentucky	Alaska
Caribbean	Florida	Washington
Virgin Islands	Alabama	Oregon
Central America	Mississippi	California
South America	Georgia	Idaho
Panama	Texas	Nevada
Vermont	Missouri	Utah
Maine	Arkansas	Arizona
New Hampshire	Louisiana	Montana
Massachusetts	North Dakota	Hawaii
Connecticut	South Dakota	
Rhode Island	Nebraska	
New York	Kansas	
Pennsylvania	Oklahoma	

<i>New Cumberland</i>	<i>Red River</i>	<i>Sharpe</i>
Ohio	Wyoming	
Indiana	Colorado	
Michigan	New Mexico	
Minnesota		
Wisconsin		
Illinois		
Iowa		
New Jersey		
Delaware		
District of Columbia		
West Virginia		
Virginia		
North Carolina		
South Carolina		
Maryland		
Middle East		

3 Major item storage assignments are:

<i>Anniston</i>	<i>Letterkenny</i>	<i>Lexington-Blue Grass</i>
AMCCOM ¹	AMCCOM ¹	AMCCOM ¹
MICOM ¹	MICOM ¹	EMRA
TACOM	TACOM ¹²	
<i>New Cumberland</i>	<i>Pueblo</i>	<i>Red River</i>
TROSCOM ¹	MICOM ¹⁶	AMCCOM ¹
AVSCOM ¹	TACOM ¹⁶	MICOM ¹
	TROSCOM ³⁴	TACOM ¹²
<i>Sacramento</i>	<i>Sharpe</i>	<i>Tooele</i>
CECOM ¹	AMCCOM ¹⁶	AMCCOM ¹
	TROSCOM ¹⁶	MICOM
	AVSCOM ¹⁶	TACOM ¹²
	TACOM ³	TROSCOM ¹
<i>Tobyhanna</i>	<i>Corpus Christi</i>	
CECOM ¹	AVSCOM	
TACOM ³		

NOTES:

¹Denotes depots that receive and store serviceable and un-serviceable items. Selection of un-serviceable will be in accordance with single/Print Depot Rationalization Study, 28 Dec 77.

²Includes materiel handling and construction equipment.

³Denotes authorized storage of serviceable major items only when space is sufficient to accommodate in assigned depots.

⁴Bridging.

⁵Denotes the depot that receives and stores serviceable and un-serviceable items. Un-serviceable are to be limited to those to be placed on overhaul contract to commercial sources in the area.

⁶Un-serviceable are authorized until the effective date of maintenance mission realignments.

(17) Unless otherwise directed, existing programming, budgeting, funding, and accounting systems remain in effect in planning for a contingency operation. Logistical support of forces is not delayed by insufficient funds, since it is expected that sufficient financial authority to support the

operation will be provided by DA. When obligations in excess of amounts authorized in current funding documents are incurred, necessary accounting for all unfunded costs will be maintained. Order-of-magnitude cost estimates (RCS CSCAB-292 (Min)) reflecting the cost for the value of materiel used to support the plan, depot handling costs, second destination transportation costs, and other costs are prepared for each AMC LOGPLAN. Other costs include overtime pay, TDY travel, additional rental costs for increased computer usage time, administration supplies, contractual services, and packing, packaging, and preserving materials.

(18) Reports of costs incident to Army operations in an emergency situation (RCS CSCAB-293 (Min)) will identify the gross costs, normal costs, and offset credits for affected appropriations reported by appropriation program, program element, and the summary element of expense to record and collect cost data for a specific emergency (the emergency should be identified on all documents requesting support).

(19) AMC subordinate commanders assigned a support mission by a AMC LOGPLAN evaluate available resources and capabilities to support the plan and identify any problem areas or limiting factors for prompt resolution.

(20) DD Form 1348 (Pre-Positioned Requisitions) submitted by CONUS installations must be edited by the NICP to insure that essential data are complete and correct for processing. Discrepancies revealed by this edit should be resolved with the requisitioner.

(21) AMC provides logistics assistance and liaison personnel who are located at the principal US Army Training and Doctrine Command (TRADOC) and FORSCOM installations within CONUS and in major commands overseas. Previously designated liaison personnel are provided from HQ, AMC staff elements upon request.

(22) Materiel shipped from supply sources, including vendors, will be afforded military level "A" preservation, packaging, and packing to provide protection during shipment, handling, and open storage at their destination.

(23) All materiel shipments will be unitized by project code into palletized unit loads, binned CONEX, MILVAN, SEAVAN, or plywood consolidation containers to the maximum extent feasible and practicable. Assembled materiel will be shipped to a designated CONUS outloading terminal for final consolidation by project code. That materiel which cannot be consolidated at the supply source (except those requiring peculiar or special handling, storage, or transportation) will be shipped to the designated AMC assembly depot

or CCP for consolidation by project code and transshipment to the designated outloading terminal. Those requiring special handling will be shipped to the terminal concurrently with the consolidated package from the assembly depot or CCP.

(24) Materiel that is to be palletized, other than class V, will be prepared in unit loads on standard 40-inch by 48-inch hardwood pallets with gross weight and height conforming to limitations prescribed in MIL-STD-147. Class V pallets will not exceed 2,000 pounds and will not exceed 52 inches in height.

b. AMC can assist deploying forces that have no demand data in developing prescribed load lists (PLL) and ASLs for nondivisional DS and GS units. The PLLs and ASLs are developed on the basis of the level of maintenance prescribed and the designation of units to be supported by each DS/GS unit as stated in the logistics annex to the OPLAN. After the PLLs and ASLs are developed, the planning agent analyzes them to insure they contain all, and only, combat essential items. If satisfied with the contents, he validates the lists.

c. AMC will develop, in coordination with the planning agent, a pre-positioned emergency supply package as a means of expediting supply action for units temporarily cutoff from their supply source. Such a package, in a palletized, rigged, ready for airdrop configuration to support the assault echelon of an airborne brigade for 2 days, has been developed for several approved OPLANs. Included in the package are class I supplies (meal ready to eat); class III (MOGAS, AVGAS, JP-4, and diesel fuel); and infantry, artillery, armor, air defense, aviation, and bulk allotment (grenades, mines, demolitions, smoke, etc.) of class V items. The pallets are numbered so that the supported command can call for specific pallets from a designated project code to be shipped for receipt by a required delivery date (RDD) (hour and date). It must be emphasized that these supplies should only be used for the purpose for which developed and not for supply actions which are not of an emergency nature. An example of an emergency resupply package is at appendix C.

7-5. Responsibilities of Higher, Lateral, and Supporting Commands and Agents

a. General Services Administration.

(1) Provides its management cognizance upon request from NICP/SICC to support the OPLAN of Army component commands of unified/specified commands.

(2) Provides, upon the request of an NICP/SICC, capability estimates for GSA items.

(3) Insures that supply shipments originating at GSA supply activities and/or vendors are afforded a level of preservation, packaging, packing, and colormarking with appropriate commodity category identification labels in conformance with the requirements of applicable specifications.

b. Defense Logistics Agency.

(1) Provides materiel under its management cognizance, upon the request from an NICP/SICC, to support OPLANs of Army component commands of unified/specified commands.

(2) Provides, upon the request of an NICP/SICC, capability estimates for DLA items in accordance with section VI, chapter 2, ARs 710-1 and 700-97.

(3) Insures that supply shipments originating at DLA supply activities and/or vendors are afforded a level of preservation, packaging, packing, and colormarking with appropriate commodity category identification labels in conformance with the requirements of applicable specifications.

c. Military Traffic Management Command.

(1) Prepares and provides, in coordination with MAC and MSC, for the CONUS movement of planned supply increments identified in each AMC LOGPLAN from supply source to outloading (air/water) terminals for transshipment to overseas destinations.

(2) Coordinates with AMC in the preselection of CONUS outloading (air/water) terminals and the determination of CTAD for each planned supply increment identified in each AMC LOGPLAN.

(3) Effects maximum consolidation of planned supply shipments by project code for outloading at CONUS (air/water) terminals to meet prescribed OTAD.

(4) Provides shipment receipt and lift data for planned supply increments to the USA LCA for each AMC LOGPLAN.

d. Military Airlift Command. Provides airlift support for the movement of planned supply increments in accordance with the supported integrated transportation plan or priorities established by the Joint Chiefs of Staff (JCS).

e. Military Sealift Command. Provides sealift support for the movement of planned supply increments in accordance with the supported integrated transportation plan or priorities established by the JCS.

f. Department of the Army. In addition to responsibilities discussed in paragraph 6-12, chapter 6,

the following staff sections are responsible for providing AMC the following:

(1) †Deputy Chief of Staff for Logistics (DCSLOG).

(a) Directs AMC and TSG, and instructs DLA/GSA to implement plans supporting Army component command OPLANs.

(b) Provides supply priorities to AMC for use in providing materiel support for supply to US forces (including fill of Army unit preparation for oversea movement (POM) requisitions), civil relief operations, PW, and US/allied noncombatants.

(c) Authorizes emergency control procedures prescribed in chapter 6, AR 725-50, for movement control status in support of applicable OPLAN and/or operations during emergency conditions.

(2) *Deputy Chief of Staff for Operations and Plans (DCSOPS).*

(a) Provides AMC (AMC LSSA), as required, JOPSREP records A, B, and C submitted by supported and supporting Army component commands for each OPLAN in accordance with vol. II, JCS Pub. 6.

(b) Provides to AMC, upon request, a SACS File and program logic on a recurring basis and/or as required.

(3) *The Surgeon General.*

(a) Provides materiel under its management to support OPLANs of Army component commands of supported unified/specified commands.

(b) Prepares TSG Supply Plan (annex M) to support each approved OPLAN and provides this annex to AMC for inclusion in the applicable AMC LOGPLAN.

(c) Prepares and submits TMRD for each TSG Supply Plan.

g. FORSCOM/US Army Forces Readiness Command (USARRED). FORSCOM/USARRED as a supporting Army component command and/or the designated planning agent (see also discussion in paragraph 6-11, chapter 6):

(1) Provides AMC with appropriate OPLAN requiring the deployment of CONUS forces to augment the forces of a supported Army component command of a unified/specified command.

(2) Provides AMC (DESCOM) with supplemental ERD/EDD for specified fragmented units in electronic accounting machine (EAM) format (FORSCOM Form 543R and 543-I-R) in accordance with FORSCOM Reg 700-2, paragraph 4-16, FORSCOM Standing Logistics Instructions (SLI) for each supported OPLAN.

(3) Determines that part of unit basic loads that cannot be stored at unit home installations and determines special storage requirements and/or arranges with CDR, AMC for storage of unit basic loads in AMC facilities as prescribed by FORSCOM SLI and AMC LP&P.

(4) Monitors the requisitioning procedures, reconciles deficiencies with CONUS installations, and coordinates the correction of discrepancies in unit basic loads with applicable NICP (AMCCOM or MICOM) as prescribed by FORSCOM SLI.

(5) Provides call-forward and supplementary address instructions when point of delivery is other than home station to AMC (AMCCOM and MICOM) for unit basic loads stored at AMC facilities for those CONUS units required to deploy/employ in a tactical configuration in accordance with FORSCOM SLI and AMC LP&P.

(6) Provides the identification of units deploying administratively to a staging base(s) and/or objective area(s) to AMC for planning the shipment of unit basic loads for those units from AMC facilities. Basic loads are shipped in scheduled supply increments to a staging base(s) or an objective area(s) for subsequent issue to units.

(7) When required, requests AMC to provide additional logistics assistance in the POM of units in the areas of maintenance and supply at CONUS installations over and above that available at installations under the AMC worldwide logistics assistance program.

(8) Provides call-forward instructions to CDR, AMC for AMC liaison personnel to report to designated headquarters/stations.

h. Army Component and Major Army Commands (EUSA, USARJ, USAREUR, FORSCOM/USARLANT, FORSCOM/USARRED, WESTCOM). Army component and major Army commands as a supported Army command and/or their designated planning agent(s).

(1) Provide AMC with OPLANs requiring AMC logistics support of theater-based Army, CONUS Army augmentation and other Army component command forces; common item support requirements for other US forces (USAF, USN, USMC) planned for deployment/employment; and special forces operations, civil relief operations, PW, and US/allied noncombatants. In the development of each OPLAN requiring support:

(a) Develop, in coordination with AMC and TSG, phased supply schedules, for the support of US forces, special forces operations, civil relief, PW, and US/allied noncombatants. (Guidance and format for the preparation of supply schedules is contained in AMC, LP&P.)

(b) Determine, for each OPLAN to be supported, the phased stockage objective (safety/operating levels) to be attained for each class of supply; level of maintenance to be performed; rates of use and/or consumption/replacement factors to be used; base development field fortification/barrier materiel requirements; operational projects requirements; and peculiar equipment support requirements.

(c) Provide AMC (DESCOM) with supplemental ERD/EDD for each Army unit fragmented or tailored to accomplish a specific mission (i.e., unit deploying/employing with less than TOE/MTOE authorizations), and for other US forces (USAF, USN, USMC) requiring common item support for Army supplied items for each OPLAN. Request supplemental ERD/EDD for each fragmented unit be submitted using EAM format FORSCOM Form 543-R and 543-1-R) contained in paragraph 4-17, FORSCOM Reg 700-2 (SLI).

(d) Request the deployment of AMC Logistics Assistance Representatives required in support of the LOGPLAN. Logistics Assistance Program support is described in paragraph 7-7. Provide administrative and logistics support to Logistics Assistance Representatives deployed in support of the LOGPLAN.

(2) Provide TSG with logistics and planning guidance necessary to compute, arrange for, and provide planned supply of their managed equipment and associated materiel required to support each OPLAN.

(3) Review AMC (NICP/SICC) and TSG computations of phased planned supply requirements prepared and disseminated for each supported OPLAN. Notify CDR, AMC and TSG of the adequacy or inadequacy of the computed supply requirements.

(4) For each AMC LOGPLAN, provide AMC the unified/specified commands integrated transportation movement schedules pertaining to planned supply shipments.

(5) Submit requests for following types of supply/related actions requiring expeditious handling to USA AMC LCA, Presidio of San Francisco, CA for all classes of supply except class VII—Medical; for class VIII—Medical, submit requests to US Army Medical Materiel Agency (USAMMA), Fort Detrick, MD:

(a) Emergency and routine requisitions.

(b) Oncall planned supply increments.

(c) Pre-Positioned Emergency Supply Package (Note: USAREUR for support of OPLANs in certain areas, maintains a pre-positioned emergen-

cy supply package similar to the package configured and maintained by AMC. Unique project codes have been assigned to identify the USAR-EUR maintained package.)

(d) Cancellation and/or suspension of planned supply increments.

(e) Shipment/lift status of requisitioned items, supply increments, etc.

(f) Tracer action.

(g) Retrograde of materiel. Reporting for disposition of excess supply materiel, serviceable, and unserviceable repairable (PAA and secondary items) for repair, overhaul, or rebuild in accordance with chapter 3, AR 755-1.

Section III. AMC RELATIONSHIP WITH SUPPORTED FORCES

7-6. AMC Interface With Army Task Force Support Command Materiel Management Center

a. The LIF maintained by the LCA in support of the MMC of the support command of the deploying force provides continuous control of combat service support prior to, during, and after an operation. Whatever the size of the task force, there will be an exchange of supply information between AMC and the materiel management element of the task force.

b. The mission of the support command is to be prepared to deploy on short notice to an area of operations, to plan, direct, and supervise the provision of specified combat service support to the task force.

(1) The support command contributes to the successful accomplishment of the tactical mission by providing combat service support to tactical units on a timely basis.

(2) In the performance of its role, the support command is expected to operate as a component of a task force in the implementation of a contingency plan or discharge of a mission. As such, the task force troop list will be structured to include combat and combat support units and the support command with appropriate combat service support units in the sizes and numbers to accomplish the assigned mission.

(3) This concept provides for an organization that is flexible in size, composition, and support capability. The support command, normally corps, will consist of a headquarters and headquarters company (HHC) with a data processing unit with a transceiver capability to the wholesale system, a materiel management center, a movement control center, and selected DS and GS supply, maintenance, field service, and administration units. Normally intermediate (GS) maintenance will not be performed in the corps area. However, if the corps is the senior Army command, it may be authorized to perform intermediate (GS) maintenance. During initial stages of buildup, these elements may be fragmented.

(4) The versatility and flexibility of the concept is insured by the development of a suitable organization that is properly equipped and thoroughly trained—a system that has been specifically designed to:

(a) Permit the commander to exercise immediate and continuous control over the combat service support being provided to supported units.

(b) Provide the commander and staff with a supply management capability.

(c) Improve the operational capabilities of the units being supported.

(d) Increase the operational effectiveness of the supporting units.

(e) Provide combat service support adaptable to different modes of operations.

(f) Provide an efficient combat service support command and control organization available for immediate deployment into an area of operations in CONUS or overseas.

(g) Provide for efficient operational interfaces of the support command system, with those systems used by higher support sources.

(5) ADPE operated by the support command may be limited initially to inventory/stock control and financial management for classes II, III (Packaged), IV, VII, and IX items of supply; and maintenance reporting and management (MRM).

(a) The support command will receive guidance and assistance on contingency plans through appropriate channels from the Commander, FORSCOM. As required for the implementation of a specific contingency plan, the MMC will receive from the Commander, AMC, with the exception of management data, all necessary contingency input data to complete the Master Inventory Record (MIR) File. These data, to be received in the specified Standard Army Intermediate Level Supply (SAILS) format and time frame, will permit the initial establishment of a data base for the designated contingency plan. In this contingency plan

support role, the support command MMC may exchange information with AMC, FORSCOM, contingency planning agents, supporting units, and supported units of one or more specific contingency plans.

(b) While operating in a passive mode, the support command may be designed to provide selected combat service support to specified post-, camp-, or station-based TOE units. In the active support of these TOE units, the support command will exchange information with the higher supply echelon and the TOE supported units. The ASLs and PLLs of units designated to provide support command support are maintained by the existing MMC functional elements and will be reviewed and used to convert data to the SAILS formats.

(c) During the passive mode, the MMC will accumulate information, data, records, and files that are vital for the continuity of logistical planning related to contingency plans and the support of the TOE units. Although some of this accumulation may be relevant to operations of the support command in another operational mode (data pertaining to those units deploying on the same contingency plan), all other accumulated data must be transferred to another organization that has been designated to continue this support function. Simi-

larly, in the deployed mode of operations, the support command will accumulate information, data, records, and files pertaining to the task force being supported which may or may not be relevant to its next operational mode.

(6) The MMC is designed to be an integrated system of automated functional components called subsystems. Each subsystem is a separate entity; however, to maximize efficiency in time and equipment use, the subsystems are centrally controlled and use common routines and data files when practicable. The system lends itself to expansion and as additional logistical and administrative automated functions are developed, they may be integrated into the system. The two subsystems that compose the current configuration of the MMC are:

(a) Supply—includes classes II, III (Packaged), IV, VII, and IX; supply financial management, and demand analysis.

(b) Maintenance Reporting and Management—includes materiel readiness reporting.

(7) The flow of information and data between the using units and the supply source and the wholesale-COSCOM interface is illustrated in figures 7-6 through 7-9.

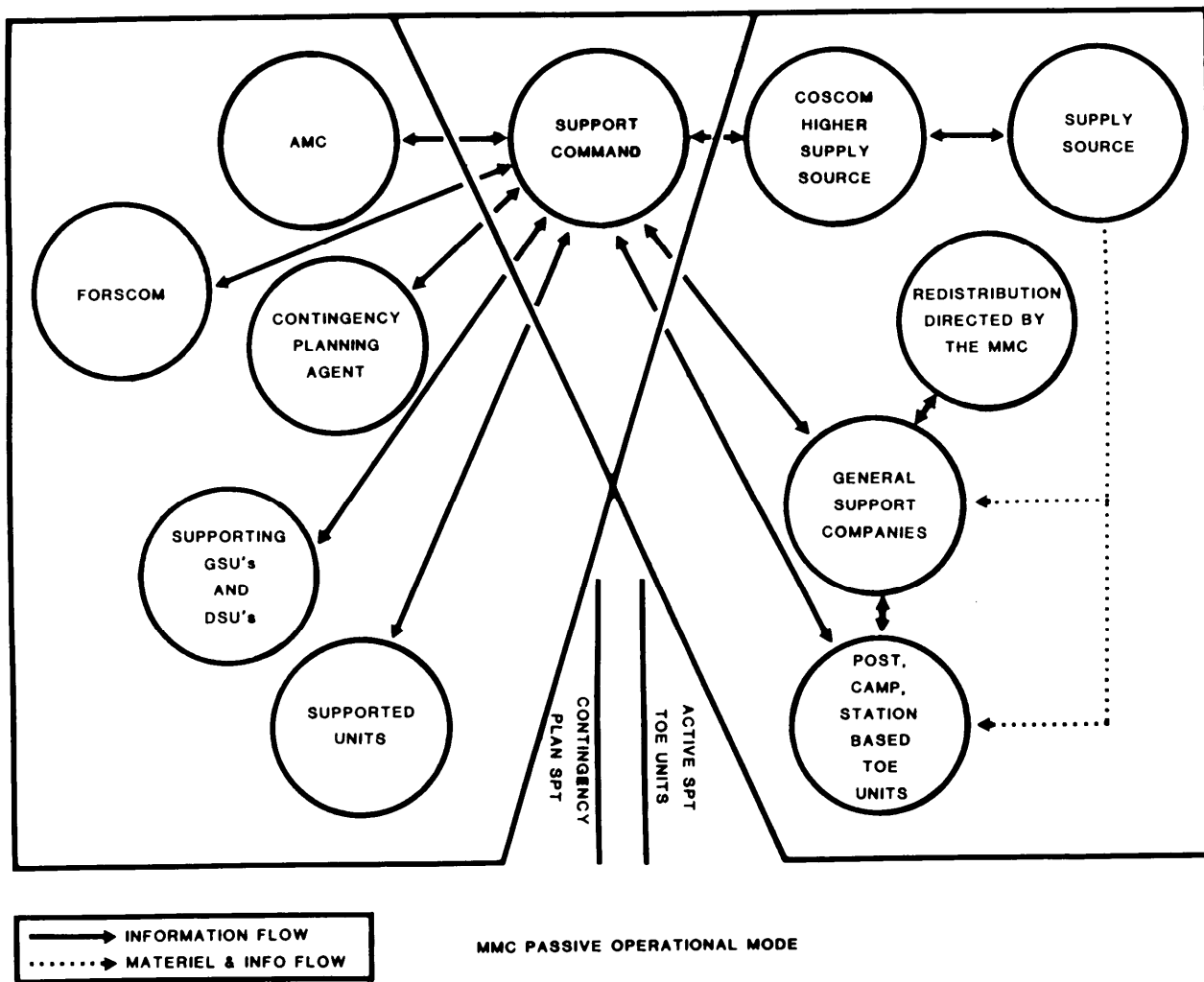

FIGURE 7-6. MMC PASSIVE OPERATIONAL MODE

Figure 7-6. MMC passive operational mode.

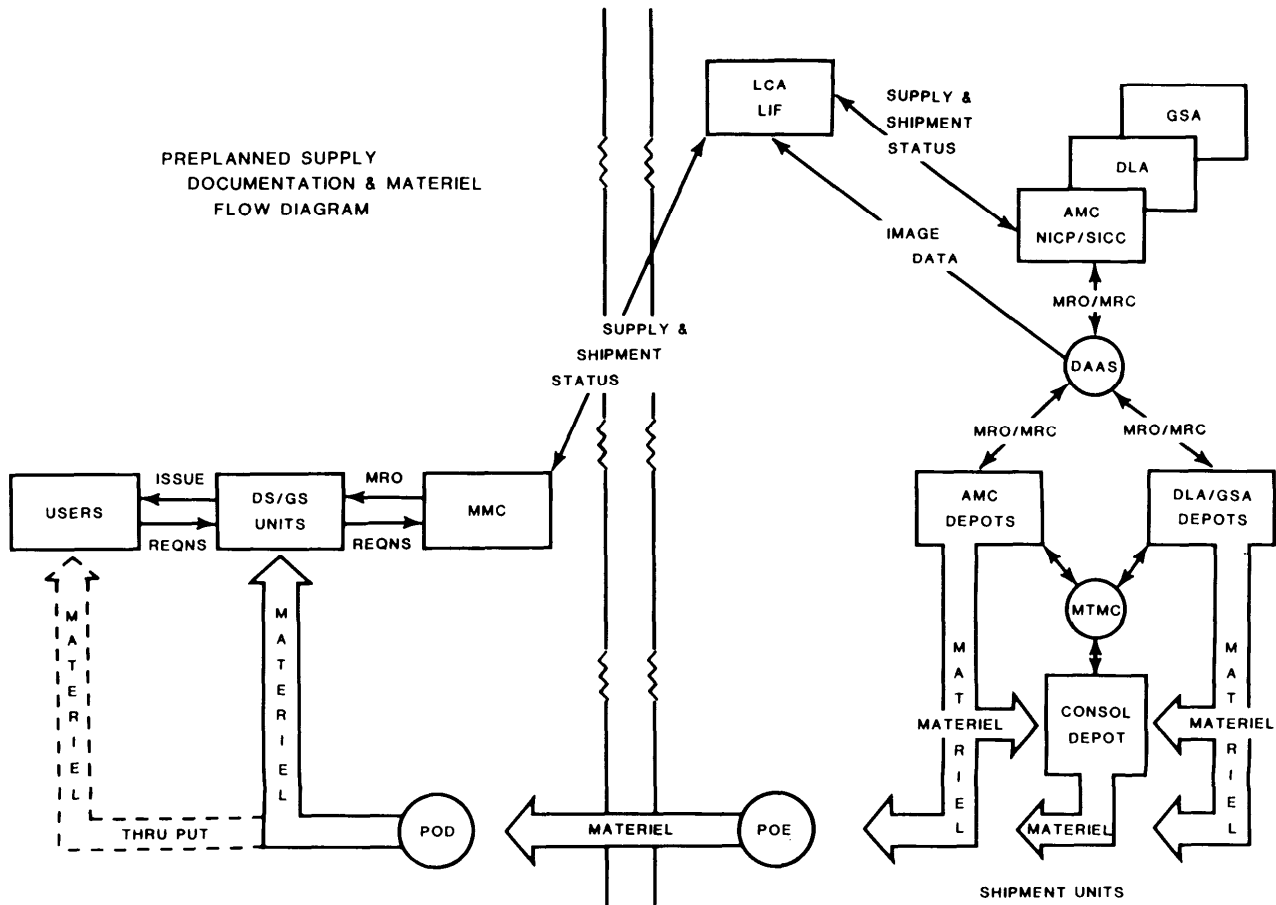

FIGURE 7-7. PREPLANNED SUPPLY DOCUMENTATION AND MATERIEL FLOW DIAGRAM.

Figure 7-7. Preplanned supply documentation and materiel flow diagram.

WHOLESALE - COSCOM INTERFACE

DEVELOPED AREA

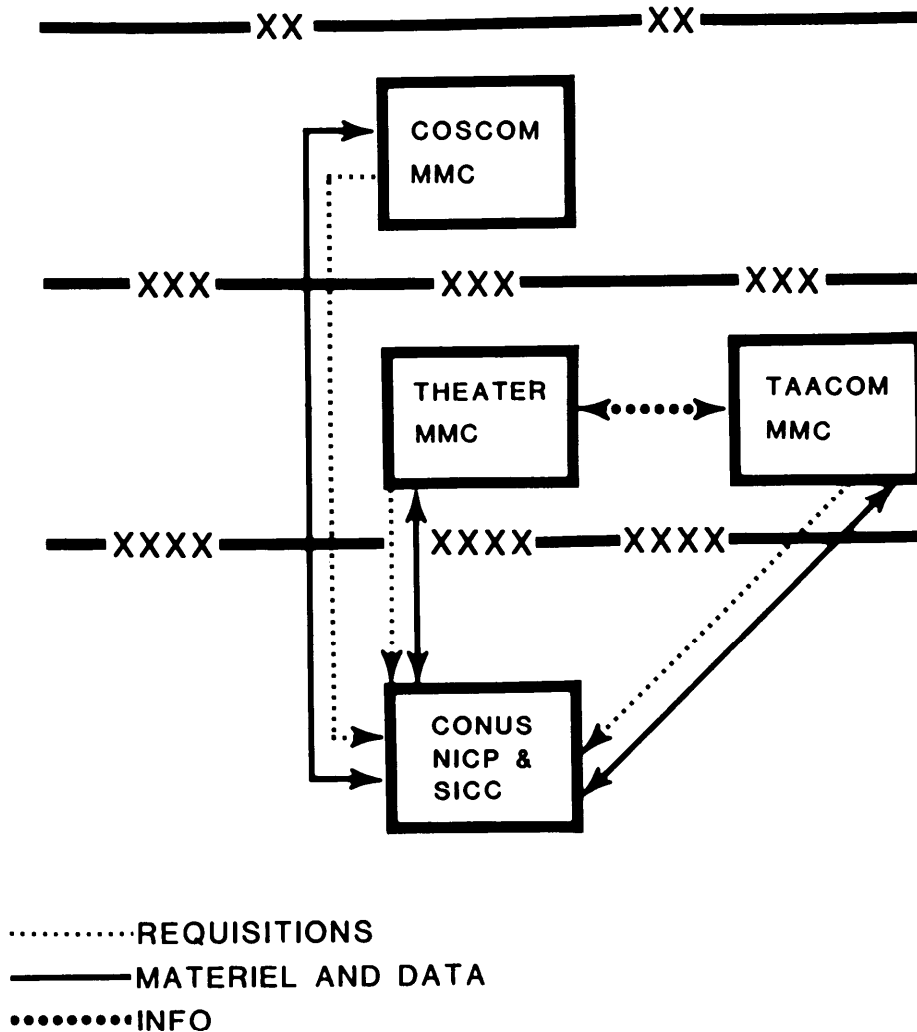

FIGURE 7-8 WHOLESALE - COSCOM INERFACE

Figure 7-8. Wholesale-COSCOM interface.

CLASS II, IV, VII (NONREGULATED) & III (PKG) (DIVISIONAL)

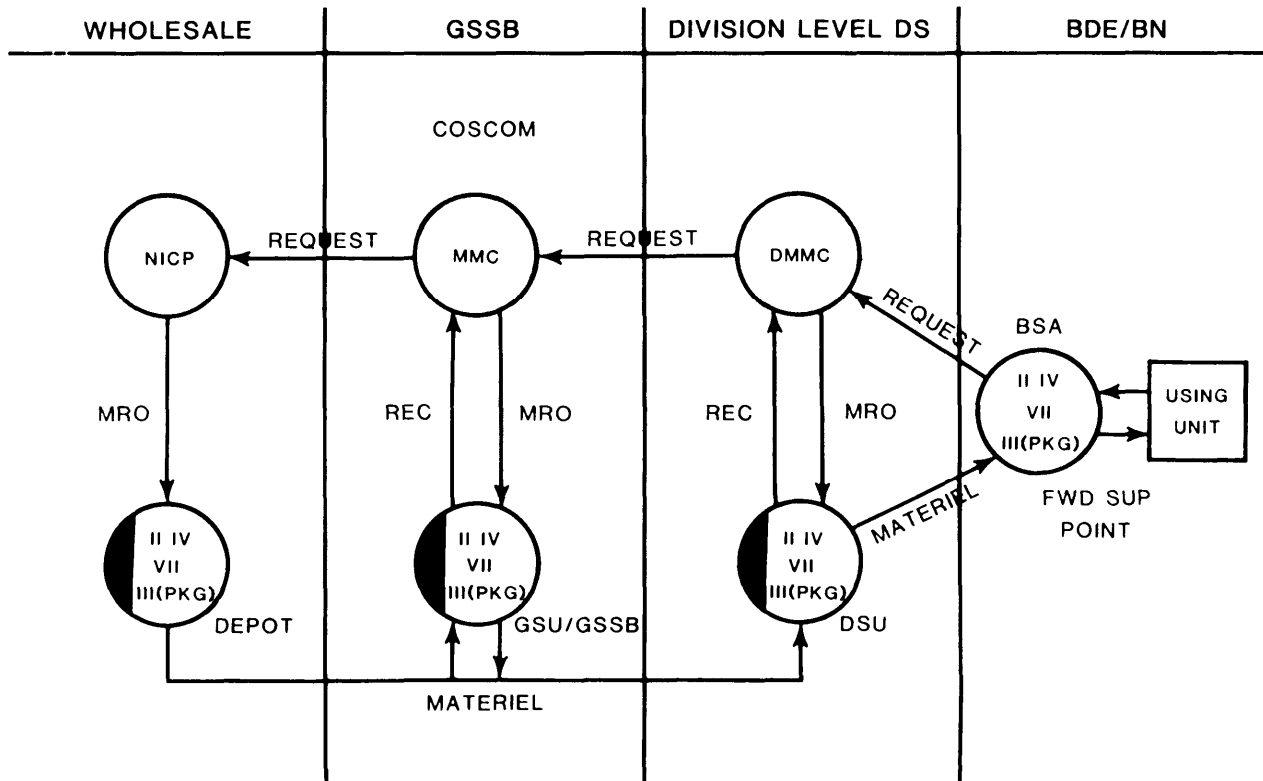

FIGURE 7-9. WHOLESALE-MMC INTERFACE.

Figure 7-9. Wholesale-MMC interface.

7-7. Logistics Assistance During Implementation of OPLAN

a. AMC maintains a worldwide Logistics Assistance Program (LAP) to provide, through Logistics Assistance Representatives (LARs), technical assistance and advice to personnel and commanders at all levels who are engaged in operations, supply, and maintenance of equipment. The prime objective of the program is to improve the materiel readiness of the active Army, the Reserve Component field forces, and allied forces by assisting commanders in resolving supply and maintenance problems. The LAP is executed by worldwide Logistics Assistance Offices (LAOs), who serve as the AMC commander's representatives.

b. When requested by the supported Army component commander or major Army commander, AMC will provide supply and maintenance assistance from needed AMC major subordinate commands during the preparation for overseas movement for units designated for task forces to implement contingency plans. Support requirements will be coordinated with supported Army component commands.

c. The size, composition, and deployment of the logistics assistance personnel in support of an OPLAN are based on: (i) the size of the task force; (ii) logistics responsibilities assigned to the Army component command and AMC for logistics support; and (iii) duration of the planned military operations.

7-8. AMC OCONUS Headquarters.

The applicable LAO, or separately established OCONUS headquarters, will exercise appropriate command or control over all AMC activities which support the assigned MACOM/theater. Each designated control element will be the single AMC command or control element responsible for supporting the MACOM/theater in peace just as it will in war. The control element will coordinate long-range planning for peacetime and mobilization, provide a single focal point for the MACOM/theater, serve as a central clearinghouse for AMC personnel going to or coming from the MACOM/theater, and in theater support to include: TMDE repair and calibration, depot maintenance, new equipment fielding activities, perform liaison to improve customer service, and logistic assistance to resolve readiness issues. Operational control of

each control element will pass to the theater commander as agreed to by Memorandum of Understanding (MOU) after emergency or hostilities. After assumption of operational control, the control element will continue to exercise centralized

control of the individual AMC activities in accordance with assigned tasks, designated objectives or priorities, and authoritative direction necessary to accomplish the theater mission.

CHAPTER 8

COMBAT SERVICE SUPPORT PLANNING

Section I. COMBAT SERVICE SUPPORT FORCE PLANNING

8-1. General

a. Combat service support (CSS) planning consists of two major planning areas—force development and force deployment. Force development is concerned with the building of a CSS force structure which will adequately support tactical operations. Force deployment is concerned with the time-phased movement of the CSS force, its accompanying supplies and equipment, and necessary resupply and personnel replacement from the Continental United States (CONUS) or other origins to the area of operations.

b. The mission, character, disposition, and capabilities of the enemy; the characteristics of the area of operations (to include terrain, climate, population, natural resources, and manmade works); the availability of troops and/or units; and the availability of transportation, supplies, and equipment determine the number and types of units for employment in a given operation.

8-2. CSS Force Development

Force development planning includes estimating personnel and equipment requirements to accomplish a mission based on tactical/strategic and logistics concepts and intelligence. Such planning normally conforms to the personnel strength ceiling authorized the theater and subordinate commands. Personnel and equipment are authorized for units in a command by The Army Authorization Document System (TAADS) (AR 310-49), which also provides the means to maintain total authorizations in the command. Planning guidance on units available to meet force requirements is given in JCSP volume II. These documents provide the centralized information needed for CSS force development planning.

a. Principles of Force Development Planning. The force planner must continually analyze requirements and insure the force list for any operation meets its operational requirements and that it consists of the minimum essential manpower and equipment to accomplish the mission.

b. Force Development Planning Requirements. Variable factors that influence CSS force requirements include:

(1) Number and types of troops to be supported, their mission, and the extent of CSS to be provided.

(2) Quantity, types, and distribution of equipment.

(3) Level of support to be provided.

(4) Maintenance policy.

(5) Construction and Real Property Maintenance Activity (RPMA) requirements.

(6) Climate and terrain.

(7) Status and availability of local resources in the area of operations.

(8) Size of the area of operations.

(9) Attitudes, availability, and capabilities of local civilians and prisoners of war (PW).

(10) Availability, capabilities, and limitations of CSS units.

(11) Enemy capabilities.

(12) Needs of the inhabitants of the area which must be met from military stocks.

(13) Medical evacuation policy.

(14) Extent of formalized agreements with host nation to provide logistical support.

c. Steps in Force Development Planning. The following steps are essential to sound force development planning:

(1) Determining tasks and resources.

(2) Determining workload based on quantitative considerations.

(3) Selecting types of units with required capabilities.

(4) Calculating the number of units required, including type B units (type B units are units with a certain percentage of military spaces filled by host nation support).

(5) Making provisions for command, control, and communications.

(6) Determining desired time-phased arrival of units at their destination.

(7) Selection of specific troop units to fill the force requirements.

d. Troop Ceiling. Within the troop ceiling, planners coordinate force requirements to achieve a balanced force that can perform the mission. Troop ceilings are fixed limits on force strength to include authorized strength on manning documents, patient, transient, and temporary duty (TDY) spaces. Therefore, a change in the requirements of one agency requires adjustments among other agencies. When a change has been justified, as a result of detailed planning, the Department of the Army (DA) may change a troop ceiling.

8-3. Planning Procedures

Force planning passes through three phases—estimation, calculation, and modification. The planner must accomplish the first phase, particularly in the case of the establishment of a new theater, with few, if any, tangible figures. He develops each successive phase with more concrete and accurate data than are available in the preceding phase until a balanced, sound troop list evolves.

a. Phase I Planning—Estimation. The planner must accomplish the initial step in the development of troop requirements with little specific data—often no more than a brief statement of the overall strength of the force to be employed or the number of divisions around which the force is to be built. Each planner uses broad experience factors, such as division force equivalents, troop and equipment densities, and replacement and consumption factors.

b. Phase II Planning—Calculation.

(1) Phase II planning begins when the planner receives phase I estimates in the form of initial, tentative troop lists. These troop lists should be more accurate than the estimates used to initiate planning in phase I. The margin of error between these initial lists and those finally accepted will depend on the adequacy of the planning factors and guidance available to the troop requirement planners, and the experience and judgment of the individual planner. At the review level, General Staff planning officers should carefully examine lists of the arms and services to determine whether the lists comply with guidance provided in the campaign plan scenario. In cases where branch strength requirements are largely dependent on total force strength, these planners should question any significant deviation from currently accepted percentages. However, environmental conditions, cultural development, and periods of time available for the buildup, to include force deploy-

ment and base development, are seldom identical in the different campaign scenarios. Certain types of troop strength requirements are highly sensitive to factors other than total force in the theater. For example, a given campaign plan scenario indicates that peak requirements for logistics support of operations will occur at a particular phase of the campaign; i.e., on initiation of the offensive at D + 90 days. Presumably, the airfields, roads, ports, terminals, and storage, maintenance, and other facilities needed to maintain the planned volume of logistics support will require approximately 12 construction battalion (CB) months to accomplish. If work were to start on D-day, four engineer CBS could do the work if they were in the theater. However, if the battalions were scheduled for deployment into the theater at 10-day intervals starting at D + 10 days, the task would require eight engineer CBs.

(2) Each planner reviews the consolidated initial troop list and decides, based on the new information, whether his next revision will increase or decrease the force and to what extent. The General Staff planning officers should appraise each planner's predictions for accuracy and recalculate the first revised troop list accordingly. The General Staff planning officers then furnish this information to all other planners so that each will be aware of the direction and limits of applicable changes.

(3) When this information is available, the planners continue phase II planning by preparing revised estimates. They discard the division force equivalent and other factors suitable only for initial estimation in favor of actual (or adjusted) figures extracted from the initial lists. They may make several revisions before they can balance lists with one another. Intelligent adjustment and careful prediction at each successive planning stage reduces the number of revisions necessary to arrive at a calculated, balanced troop list to complete phase II.

c. Phase III Planning—Modification.

(1) The consolidated troop list produced in phase II provides a balanced force, each element of which can perform its mission without modification. The planner then applies the modifications that policy, command direction, or conditions peculiar to the theater under consideration dictate in phase III. For example, the planner may substitute indigenous labor for military personnel at this stage.

(a) This action will throw the developed troop list out of balance, possibly requiring several successive revisions, such as those made in phase

II, to balance it. This substitution will affect various services differently; i.e., the impact on maintenance units will be relatively minor because the equipment density will not change significantly; but the impact on the medical troop list will be substantial because medical support is provided primarily on the basis of military strength. Other services will be affected to a greater or lesser extent, depending on the change in military strength and the equipment required.

(b) Because substitution of indigenous labor for military personnel in phase III will cause an imbalance and make additional revisions necessary, the planner should consider making such substitutions earlier in the planning process. Earlier substitution will simplify matters for some services, such as medical, interested primarily in military strengths; but it will complicate matters for those services that must prepare lists of equipment for the indigenous labor force. The chief of the planning group decides the procedures; but the various CSS representatives should present the advantages and disadvantages of each method and make an appropriate recommendation in each case. A 100-percent military troop list against which planners can make augmentations and comparisons is desirable.

(2) Planners frequently impose arbitrary personnel ceilings on the CSS elements. Planners should not apply these ceilings until phase III because the reduction in strength may not be proportional for all services or for all units within a service. If the planner knows the full military strength required to accomplish a mission, he can adequately appraise the effects of a reduced strength and report them to the head of the planning staff and force commander.

(3) The planner makes final distribution of troops by zone or area and determines the location of service areas and other major installations in phase III. If the planner has tentatively accomplished the foregoing for each troop list prepared in phases I and II, he should find the final determination is simple because of his increasing awareness of the deployment of troops of other arms and services throughout the theater and his adjustment of his own distribution to meet the probable load.

8-4. Designing the CSS Structure

a. The company is the normal basic organizational unit for CSS organizations. With few exceptions, there are no fixed organizations above this level. Normally, the company possesses the necessary organizational, administrative, and logistics capability to be self-sufficient. Companies can pro-

vide elements to support units for short periods of time. Cellular detachments and teams provide special capabilities when required and receive any organizational support necessary from the larger units to which they are assigned or attached. Units are organized to function, to the maximum degree, in either the combat zone (CZ) or the communications zone (COMMZ). Headquarters units serve as command and control elements for assigned and attached units that are selected in the required number and with the necessary capabilities to best meet the operational situation.

b. Flexibility in CSS organizations is essential to meet the full range of tasks that may arise. The force planner designs the CSS structure to accomplish the support mission in the most efficient and responsive manner. Use of company-sized units in this manner is known as the "building block" principle and is a fundamental technique in developing CSS organizations.

c. An important application that illustrates the building block principle is found in the Corps Support Command (COSCOM). COSCOM operations, organization, and capabilities are the composite of the CSS activities performed by the separately organized Table of Organization and Equipment (TOE) units that may be assigned or attached. In general, each of the various headquarters, companies, detachments, and cellular organizations is designed to perform a given workload in specific areas of CSS. These separate units, with proper adjustment to insure self-sufficiency, can be used to support organizations of less than division size. Battalion, group, and brigade headquarters are added when the CSS structure expands.

d. The TOE of the various CSS units express unit capabilities in quantitative terms and provide a ready reference for determining an appropriate CSS force list. To tailor any CSS force organization to meet the needs of the supported commander, the total CSS requirement must then be compared against the unit capability of the appropriate CSS unit to determine the CSS force requirement. The TOE mission and capability of CSS units to meet these requirements can be found in FM 101-10-1 for divisional CSS units and in FM 101-10-2 for nondivisional CSS units.

e. In certain situations, the planner may find that the CSS force structure is inadequate either in terms of quantity or required skills. This could necessitate a request for more CSS units, the increased use of host nation support (HNS), or in the most extreme case, change of the OPLAN concept.

Section II. SUPPLY PLANNING

8-5. General

a. Supplies include all items necessary for the equipment, maintenance, and operation of a military command, whether required for administrative or combat purposes. Supplies may be referred to as materiel (AR 31025).

b. The function of supply is defined in AR 700-126 as "the acquisition, distribution, care of materiel in storage and salvage of supplies, including the determination of kind and quantity of supplies."

8-6. Responsibility for Supply Planning

a. Joint Commander. The joint commander is responsible for insuring that forces in the theater receive adequate supply support. In principle, each service is responsible for its own supply support, except as otherwise provided in agreements. In practice, in some areas, the dominant service will supply all service-peculiar items to all US forces. The joint commander allocates supplies among the services when necessary.

b. Theater Army (TA) Commander. The TA commander is responsible for supplying US Army forces in theater and supporting the US Navy, Air Force, and other forces with Army items as directed (see subparagraph *a*). The TA commander:

(1) Operates the Army supply system through major subordinate commanders. He provides broad supply plans and policies to guide the subordinate commands.

(2) Establishes policies for allocating resources among major subordinate commands. Normally, he does this by policy directives covering several classes of supply. He may allocate specific items because of their special nature or critical status.

(3) Arbitrates differences among major subordinate commands with respect to supply support.

(4) Reviews and recommends approval to Headquarters, Department of the Army (HQDA), for operational project requirements.

(5) Within DA-authorized theater levels, establishes supply levels for the COMMZ and CZ.

c. Theater Army Area Command (TAACOM). The TAACOM commander is responsible for the provision of specified CSS on an area basis through its subordinate organizations to all Army forces located or passing through its assigned area of the COMMZ. The TAACOM also provides intermediate (GS) maintenance in support of the theater supply system and GS supply to the corps that the particular TAACOM supports. It may also provide

specified support to other US and allied forces as directed by the theater Army commander.

d. Corps Commander. The corps commander supplies corps units, supplies common items to other services as directed, and supports civilian agencies as directed. He exercises supply control over corps supply operations. He receives estimates and recommendations from elements of his command (and other agencies for which he has supply responsibility) and obtains supplies from CONUS and local sources. He allocates critical, regulated, and command-controlled items and announces controlled supply rates for class V to subordinate elements. He allocates special ammunition to include specifying the number of complete rounds authorized for expenditure during a specific period or phase of an operation.

e. Division Commander. The division commander is responsible for supply to his own elements and for making their needs known to the next higher supply echelon. Normally, divisions obtain supplies in accordance with a prepared distribution plan direct from general support (GS) supply units in the corps rear area.

8-7. Requirements Determination

a. General. Supply requirements are the statement, in a plan or request, of the need for specific quantities of supplies and equipment over a specific period of time. Theater requirements are computed based on knowledge of strategic and tactical plans, accumulated demand data or previous experience factors, troop strength, end item density, and other guidance available at each echelon of command. As a basis for other planning estimates (e.g., transportation, troop, and construction requirements), General Staff planners develop gross tonnage estimates of supply requirements. Materiel Management Centers (MMC) at TA and COSCOM develop quantities of each item required when this is not determined in CONUS by US Army Materiel Command (AMC), Defense Logistics Agency (DLA), General Services Administration (GSA), and other similar agencies.

(1) *Levels of Supply.* HQDA prescribes levels of supply authorized for oversea armies in terms of days of supply. Usage factors and experience data vary somewhat among different items of supply. To provide uniform methods of calculation, days of supply are converted to pounds per man per day, to numerical quantities of items, or to their quantitative units. Collectively, these levels constitute the stockage objective of the command concerned

and permit requisitioning, control, movement planning, and associated activities. The stockage objective includes all stocks except those in the hands of using units. The TA commander echelons supplies, within DA authorized totals, by prescribing levels of supply for the CZ and the COMMZ.

(2) *Authorized Stockage List.* Targets for ASLs and prescribed load lists (PLL) are established by AR 710-2. These targets should be considered as guidelines only. The objective is to maintain an average demand accommodation of 80 percent, using variable stockage criteria and accommodation by materiel category. Additional items maybe justified and retained if considered essential by the theater commander. The operating level (OL) for CONUS is 15 days and OCONUS is 30 days. The safety level (SL) for OONUS is 5 days and OCONUS is 15 days. Mandatory Stockage List (MSL) and Mandatory Parts List (MPL) stockage must first be established with priority over other inclusions, in accordance with DA Pam 710-3 and other pamphlets in the 710-2 series, under the Combat ASL and PLL programs.

(3) *COMMZ Levels.* An established theater COMMZ stocks 30 days of non-air lines of communications (AI-DC) combat essential items which are normally shipped by sea from CONUS, such as ammunition, fuel, food, major end item assemblies, and heavy tonnage class IX items. This level should not exceed 10,000 lines. Class IX and selected class II ALOC items are shipped directly to the DS/GS users.

b. Initial Requirements. Determination of initial issue quantities is made by using current TOEs, tables of distribution and allowances, equipment modification lists, and similar authorizations. When computed, "in-country" computations depend on knowing the following:

- (1) The number of troops and the allowances under which the troops and installations will be supplied.
- (2) Status of supplies in the hands of troop units.
- (3) Dates of arrival or activation of troop units.

c. Replacement and Consumption Requirements. Replacement and consumption (R&C) requirements are necessary to keep initial equipment at authorized quantities and to replenish supplies consumed, expended, lost, or destroyed. When supplies are received daily, needs can be met with a minimum operating level of supply. When supplies are received less frequently, it is necessary to increase the levels of supply. Computation of replacement and consumption requirements is based on authorized days of supply and the following:

- (1) Projected troop strength for the period.
- (2) Changes in composition of the forces supported.
- (3) Seasonal requirements.
- (4) Anticipated operations that create special requirements such as operations in a nuclear chemical environment.
- (5) Revision of replacement factors and consumption rates as a result of added experience.

d. Reserve Requirements. Reserve requirements represent quantities of items which are excess to immediate needs, but are required to meet anticipated demands. Ammunition, fuel, food, major end items, selected class II, IV and IX (heavy tonnage items) are normally shipped by sealift. This sealift support from CONUS may not be adequate for the first days of a conflict. Airlift support for these items will not be available due to higher priority loads. To overcome this transportation shortfall, combat essential non-ALOC supplies and equipment should be pre-positioned in the theater as pre-positioned war reserves (PPWR). TA commanders will have to justify their requests for reserve stocks. The actual stocking of reserves is authorized in DA controlled programs. Responsible commanders issue directives and guidance to subordinate commands for accumulating, rotating, maintaining, and replenishing reserve stocks.

e. Project Requirements. Project requirements are supplies to perform a specific task that are not part of normal allowances. An approved project requirement is one for which DA has authorized the issue of supplies.

(1) Project requirements involve all classes of supplies and include initial issue equipment as well as replenishment supplies. Project requirements are classed as follows:

(a) Operational Project Requirements. Additional equipment or supplies for tactical operations.

(b) Development Project Requirements. Supplies for construction, reconstruction, development or remodeling of military installations, utilities, and facilities.

(c) Maintenance Project Requirements. Quantities of class IV supplies for normal day-today maintenance of military installations, utilities, and facilities.

(2) Project requirements may originate overseas or may be a part of the DA plan for a specific operation. Commands submit project requirements early so that DA can consolidate all demands. Because of long procurement leadtimes, DA may ini-

tiate requirements before an Army commander is designated. Project requirements so initiated are later revised based on the commander's recommendations.

(3) Project requirements include bills of materials, which are technical documents listing the supplies and components needed for a particular project. Complete bills of materials may be prepared overseas, but frequently AMC prepares them based on a general statement of the task to be accomplished. The latter method has advantages, especially when construction is necessary, since technical specialists familiar with design, nomenclature, and sources of materials are usually more readily available in CONUS.

(4) The TA commander's responsibility for project requirements consists of:

(a) Reviewing DA prepared project requirements to determine their suitability and to recommend necessary changes.

(b) Determining the need for additional project requirements, and where applicable, obtaining HQDA assistance and approval.

(c) Issuing necessary directives to subordinate commanders to obtain needed supplies and to take action to complete the project requirement.

(d) Allocating tonnage made available for movement of materials to the theater.

(5) Examples of supply projects that must receive special considerations are:

(a) Fixed signal installations.

(b) Base installations, including depots, shops, assembly areas, port facilities, hospitals, rest areas, military confinement facilities, Prisoner of War (PW) enclosures, Army exchanges, and postal systems.

(c) Rehabilitation or construction of transportation facilities; airfields; petroleum, oil, and lubricant (POL) pipelines and related facilities; field fortifications and protective construction; and barrier and denial operations.

(d) Specialized equipment and increased levels of supply needed for special operations.

8-8. Preplanned Supply

a. Normally, an established overseas command gets supplies from CONUS by requisitioning them. Supplies for a new command, however, usually are shipped on a preplanned schedule both from CONUS and other sources. Units deployed to new areas take organic equipment and supplies for replacement and maintenance for a specified period. Accompanying supplies are initial issue and are the basic load, prescribed load, and mission load

which sustain the unit until continuing resupply can begin. The composition and number of days of supply will differ for units deploying by air from those deploying by sea. Units deploying by air normally deploy with 2-5 days of combat essential classes I, III, and V, selected II and IV, VII and 15 days of class IX. Units deploying by sea carry their authorized loads (ASL, PLL, basic load of class V) plus added supplies for buildup of theater levels. (See also paragraph 7-4.)

b. Preplanned supply must be called forward by the theater MMC and phased into the theater before depletion of the accompanying and sustaining supplies.

c. As soon as possible, normal requisitioning procedures are established. DA sets the date on which preplanned supply ceases, based on the commander's recommendations. All supply agencies coordinate their actions to prevent an interruption of supply and to avoid duplicating shipments. In accordance with DA policies, the MMC transmits requisitions to the Defense Automatic Addressing System (DAAS) where they are screened by Defense European and Pacific Redistribution Activity (DEPRA) and then forwarded to the appropriate DLA, Service Item Control Center (SICC), AMC major subordinate commands, or GSA regional office. These requisitions indicate the ultimate consignee, wherever possible, to allow direct shipment from the ports.

d. Army-wide shortages may cause DA to except certain items from requisition and normal supply procedures. In such cases, commands may be required to report requirements, quantities on hand, due in, shortages, and expenditures. Based on these reports, DA allocates available supplies on a distribution schedule and has them shipped automatically in accordance with priorities. Alternatively, the commander may be informed of the allocation and be authorized to call the item forward by requisition. (Procurement Appropriation, Army (PAA) major items are always allocated.)

8-9. Supply Planning Procedures

a. Supply planning and, more specifically, the procedure for making quantitative supply estimates are important in planning and conducting CSS in large-scale combat operations. The importance of this procedure stems partially from the fact that the receipt, storage, and distribution of supplies is a principal mission of the CSS organization. Together with the maintenance and transportation systems, the supply system provides for the materiel needs of our forces. The significance of the supply estimate to the CSS planner is that

quantitative supply estimates provide a basis for other logistics planning procedures. The supply estimate is the quantitative requirement or the workload for the supply system. The distribution of supplies requires the utilization of transportation and the facilities associated with the movement of supplies forward to the CZ. The quantity of supplies to be distributed becomes the workload against which the transportation system is compared; thus, the quantity of supplies is significant in transportation troop planning. The quantity of supplies to be stored or distributed can be related to physical facilities and, thus, is significant in defining the construction effort required and the composition of the engineer command which will perform such construction.

b. The magnitude of the supply mission must be measured in terms of quantities of individual line items. In determining the composition of the basic loads of ammunition, the ASLs and PLLs and other supplies and materiel that are to accompany deploying troops, units compute quantities of individual line items required. Similarly, AMC national inventory control points (NICP) and SICC's compute resupply requirements by individual line items as described in paragraph 7-3. MMCs must be concerned with the details of requirements for and daily status of each item used by the forces in the theater. A meaningful unit of measure for planning purposes at unified command, TA, or corps level is pounds per man per day translated into tonnages or barrels.

c. The supply planners at unified command and TA must consider supply requirements in terms of reception, storage, and distribution.

(1) Estimates of supplies to be received and distributed throughout the COMMZ and CZ are generally categorized into dry cargo (which includes all classes of supplies except bulk fuel and water).

(2) Supplies stored within the COMMZ and CZ are generally categorized as dry cargo, ammunition, bulk fuel, and water. Based upon these storage restrictions, GS storage areas, ammunition supply points, petroleum facilities, and water facilities are developed to provide storage sites for tonnages required to sustain the theater of operations.

(3) The quantities of supplies to be moved into the theater and received, stored, and distributed within the theater are expressed in gross figures. These can be obtained by multiplying the strength to be supported times the pounds per man per day to be handled and then converted to tonnages and/or barrels. The results of this initial planning will normally not vary significantly from the final plans.

8-10. Logistics Estimates

a. Logistics estimates are prepared and used by the staff primarily to identify tonnages to be received, stored, and moved (distributed) within the various parts of the theater.

b. When estimating supply tonnages, three basic items of information are required: troop strength, consumption rates, and the level of supply (in days of supply) authorized for that theater or operation. For certain materiel supply estimates, an additional item of information is required: equipment allowances, which are the prescribed amounts of items of supply and equipment provided for an individual or organization.

(1) *Troop Strength.* Information on the troop strength to be supported is normally obtained from the plans of higher headquarters, or from personnel status reports of appropriate echelons for current operations. When there are multiple service components within the supported force (e.g., Army, Air Force) and when the various components consume supplies or categories of supplies at significantly different rates (i.e., Army in CZ, Air Force in COMMZ, and Army in the theater), troop strengths are broken down into categories that conform to those different rates of consumption. When supply tonnages are being estimated for analyzing distribution (movement) capabilities, troop strengths must be further broken down by location within the theater (e.g., Combat Zone or COMMZ).

(2) *Consumption Rates (Resupply Rates).* The rate supplies (or specific classes of supplies) are consumed is best obtained from experience data, assembled for a particular operation being supported. In the absence of experience data, FM 101-10-1, table 3-3, provides rates based upon modified World War II and Korean War experiences. These factors are referred to as consumption rates because they reflect the weight of items consumed at a uniform daily rate based on strength, and are expressed in pounds per man per day. For initial planning, these rates can be used for gross supply estimates. When consumption rates from FM 101-10-1 are used, the supply planner must apply judgment and modify those rates based on the particular situation. Resupply rates can be expected to increase drastically in a nuclear, biological or chemical environment due to potential excessive losses of supply and equipment.

(3) *Level of Supply.* Level of supply was previously covered in paragraph 8-7a(1) of this chapter.

8-11. Basic Supply Planning Computations

When preparing estimates of supply requirements (gross tonnages), the planner is concerned with three basic quantities of supplies to be handled: resupply, buildup, and storage tonnages. Specific procedures to be used for these computations are contained within chapters 3 and 6 of FM 101-10-1.

a. Resupply. Daily resupply requirements represent tonnages consumed each day by a specified force, and are normally expressed in "tons per day." They are computed on the basis of the average troop strength during the period for which estimates are being made. It is impracticable to compute daily resupply requirements for each day, thus, average strengths are used. The use of average strength figures may create an excess of supplies based upon end strengths, and a shortage of supplies based on beginning strengths during a period of troop strength increase. These shortages and excesses should balance out over a given period of time, thereby, providing the supply planner a strength figure that will reflect the needs of the organization.

b. Buildup. Buildup tonnages represent the increased amount of supplies in addition to the daily resupply requirement needed to establish a specified stockage objective (level of supply), usually expressed in days of supply. TA will normally receive the mission to establish a specified stockage objective during a given period. While this mission could theoretically be accomplished by receiving or distributing all the required tonnages on the last day of the period, it is more efficient to constitute the stockage objective throughout the given period. Estimates of tonnages required will change whenever either or both of the following conditions exist:

- (1) The prescribed stockage objective is changed during the period.
- (2) The supported troop strength changes during the period.

c. Total Daily Tonnage. The total tonnage to be received each day in the theater includes the daily resupply requirement and the daily buildup tonnages. This estimate of supply tonnages is furnished to members of the staff to permit a comparison with the throughput capacity of ports, beaches, and airfields.

d. Storage Requirements. The staff, using all available information, estimates the total quantity of supplies to be stored in each portion of the theater during a particular time period. These estimates of tonnages to be stored are used in estimating construction requirements, allocating existing

facilities, and estimating requirements for troop units. Normally, the commander will echelon supplies throughout the theater. Supplies to be stored within the COMMZ are normally divided among GS storage areas, POL facilities, ammunition supply points, and the Medical Supply, Optical, and Maintenance Units (MEDSOM). A breakout of the location of the various classes of supplies as they are stored in the COMMZ is as follows:

(1) *GS Storage Areas.*

(a) Class I—Subsistence.

(b) Class II—Clothing, individual equipment, tentage, organizational tool sets and toolkits, handtools, dry batteries, test equipment, and administrative and housekeeping supplies and equipment.

(c) Class III—POL (packaged petroleum products) which include: lubricants, greases, and specialty items put into containers with a capacity of 55 gallons or less.

(d) Class IV—Construction materials, to include installed equipment and all fortification/barrier materials.

(e) Class VI—Personal demand items (non-military sales items).

(f) Class VII—Major end items.

(g) Class IX—Repair parts (less medical-peculiar repair parts).

(h) Class X—Materiel to support nonmilitary programs.

(2) *POL Facility.* Class III-Bulk fuels.

(3) *Ammunition Supply Points.* Class V-Ammunition of all types (conventional and special).

(4) *MEDSOM Battalion.* Class VIII—Includes both supplies and repair parts related to medical-peculiar items.

(5) *COMMZ Storage Determination.* In determining the total tonnages of the various classes of supply to be stored in the rear portion of the COMMZ, the forward portion of the COMMZ, or the CZ, daily resupply tonnages are not considered because these supplies are consumed daily. To compute storage requirements, the basic formula can be found in chapter 6, FM 101-10-1.

e. Distribution Requirements.

(1) The staff estimates the total tonnages required to be moved into each portion of the COMMZ and CZ. A detailed comparison is then made of the transportation capabilities versus the transportation requirements within the theater.

(2) The estimates of daily tonnage required to be moved are used to determine the adequacy of the existing transportation network and to estimate the construction effort and the requirements for troop units.

(3) Using the total daily supply tonnage requirement, the planner determines and plans for the movement of supplies throughout both the COMMZ and the CZ.

8-12. Ammunition Supply

a. Ammunition (class V) supply consists of bombs, explosives, mines, missiles, rockets, propellants, and other associated items. It also includes components of class V items; e.g., boosters, rocket motors, jet assisted take-off devices, nonnuclear and nuclear warheads, and associated repair parts or assemblies which, because they contain explosives or are peculiar to ammunition, are supplied through ammunition channels. Its demands and consumption rates vary with the type of combat and within each unit as responses are made to demands of fire and maneuver. While the supply of ammunition is a logistical action, its expenditure is a matter of tactical command decision. Both conventional and special ammunition are allocated from higher to lower command. The logistician at intermediate headquarters cannot influence the control of supply or resupply of ammunition. He can and does provide the means to carry out the desires of the tactical commander.

b. The commander of a unified or specified command originating an operation plan (OPLAN) must have the internal capability to fully support his OPLAN or have made positive arrangements for that support from other commanders or through international agreements. The supported unified commander includes, within the ammunition appendix to his logistics annex of the OPLAN, the concept of nonnuclear ammunition supply operations, ammunition requirements to execute and support the OPLAN for a designated period of time, to include assigned US forces; augmentation forces being deployed to the area; resupply requirements; requirements for allies being supplied by the United States; and support of other agencies from US stocks. Also addressed are ammunition stocks on hand or available (such as Propositioned War Reserve Stocks (PWRS)) which can be used to satisfy requirements, the capability of facilities to store and handle ammunition, the ability to transport it, limiting factors and ammunition handling systems to support the OPLAN.

c. Supporting commanders and service component commanders develop plans to support the supported commander's OPLAN, to include the

necessary organizations to provide ammunition support.

d. The characteristics of ammunition and ammunition planning must be understood by the logistics planner and are discussed in FM 9-6 and in paragraph 3-8, FM 101-10-1.

8-13. POL Supply

a. The responsibility for overall planning of petroleum logistics support rests with the supported unified or specified commander originating an OPLAN. Each OPLAN submitted to the Joint Chiefs of Staff (JCS) for approval contains a petroleum appendix to the logistics annex. This appendix provides the concept of petroleum supply operations. It addresses the POL requirements to execute and support the OPLAN for a period determined by the commander to include US forces in the theater, augmentation forces being deployed to the theatre, resupply requirements for these forces, and requirements for allies, civilians, and other US agencies to be supported from US stocks. The annex also considers the POL products on hand or available to meet the requirements, along with the availability and capabilities of facilities to store and handle the POL, and the capabilities to transport it to required areas of use and any limiting factors.

b. Supporting commanders develop plans and time-phased requirements for petroleum support during the deployment phase of the implementation of the OPLAN. The service component commanders develop supporting plans for requirements of forces in the theater and those being deployed to the theater, to include resupply requirements.

c. Of major concern is the supply of bulk fuel.

(1) Bulk fuel inventories are made up of Peacetime Operating Stocks (POS) and PWRS. The military services compute pre-positioned war reserve requirements (PWRR) by grade or product and location based on the annual Secretary of Defense Planning and Programming Guidance, approved force structure, and joint strategic planning guidance. Procedures for computing PWRRs are prescribed by each military service. PWRRs for all services are consolidated by the Defense Fuel Supply center (DFSC) and storage space allocated in defense fuel support points. PWRSs are pre-positioned and maintained in accordance with Secretary of Defense and JCS guidance at installations of ultimate use, as much as possible. That which cannot be stored at installations of ultimate use is stored at a terminal storage facility. Planning for the movement of PWRS from storage lo-

cations between bases in CONUS and to the point of use in oversea areas in an emergency is the responsibility of DFSC. However, inland distribution of all US-based forces of all DOD components within an overseas theater of operations is the responsibility of the Army. Petroleum stocks held by the military services and DLA are subject to allocation by the JCS and overseas by the unified commanders. However, normally, PWRS will not be reallocated.

(2) It is necessary that essential PWRS class III products exist before D-day, to insure adequate support to military forces during the initial phases of a war.

(3) Adequacy of bulk fuel storage capability in the deployment area; the reluctance of commercial contractors to build storage facilities to support military demands; and the time required for the services to obtain program authority to construct adequate facilities to efficiently use tankers expected to be available must be considered in planning class III support. To provide for adequate storage and distribution facilities, the unified commander and the component commanders accomplish long-range coordinated planning on a 5-year projection, when possible. If it is determined that large-scale new petroleum facilities are required, the preferred order of priority for providing them is:

(a) Military construction.

(b) Contractor construction, leased to the military for operation.

(c) Contractor construction and contractor management under specific conditions providing for adequate US Government control to protect the Government's investment.

(d) Contractor construction augmenting existing commercial facilities with clear contract provisions to establish military preferential priorities.

(4) Requirements during the first 60 days of a general war are considered critical. During this period, requirements are to be satisfied from the following sources, to the extent possible:

(a) Current contract/defense fuel support sources.

(b) New procurement by DFSC.

(c) Allocation from the FEMA, GSA/DOE, and the Department of Transportation (DOT).

(d) Defense fuel support point PWRS.

(5) Class III supply planning is discussed in paragraph 3-6, FM 101-10-1. The procedures for management of petroleum products are contained

in Department of Defense (DOD) Manual 4140.25-M.

8-14. Water Support

a. General. Water is a critical combat commodity required for personal consumption; sanitation; cooking; maintenance; equipment operation; decontamination of personnel, equipment and facilities; and a host of other purposes. In an industrialized area or in an environment where fresh surface and subsurface water is sufficient to provide the requirements of the force, water supply is an operational requirement involving a minimum of management except in emergencies.

b. Responsibilities.

(1) The Army was designated DOD Executive Agent for land-based water resources on 22 September 1980. As the DOD Agent, the Army will coordinate policy and procedures concerning joint plans and requirements for all DOD components having responsibility for water resources in support of land-based forces; accomplish water resource research development and acquisition for all DOD components; and develop, in coordination with the services, OJCS and other DOD agencies, joint doctrine for employment of water resources in support of joint operations. Each Service will provide its own water resource support. However, water resource support beyond a service's capability in a joint operation will be provided by the Army or another service, as appropriate.

(2) Within the theater, the TA commander is responsible for the control and distribution of water to US Army forces; other US services; and as required, to allied support elements. The senior TA engineer headquarters and its subordinate organizations, are responsible for the detection of subsurface water, drilling, construction, and the repair and maintenance of support facilities. The command surgeon performs the functions of testing associated with water source approval, continued monitoring of finished water, and provides interpretation of the water testing results. Water quality monitoring is primarily the responsibility of the preventive medicine aspects of the MEDCOM/corps while routine testing is performed by water supply units. Supply and Service (S&S) water elements will provide direct support, and water supply companies will provide general support within the theater.

c. Operations.

(1) Potable water resupply in temperate and tropical regions will normally be accomplished by supply point and limited unit distribution from water points operated by elements within the S&S

structure. S&S elements will draw and purify water from ponds, lakes, streams, existing wells, or wells drilled by engineer units. They will also provide DS to elements supported by the supply point.

(2) Within the corps, potable water supply is on a demand basis. When divisions are unable to provide sufficient water for their use, a request is made to the COSCOM for assistance. Water supply points are established in the corps as far forward as possible depending upon the location of available water sources, consuming units and the commander's tactical plan. The most forward point is normally located in the brigade support area. Supported units draw water from supply points using organic transportation. Units are augmented with storage and distribution equipment to support operations when required. Water support in the corps rear area is provided on an area basis by nondivision S&S companies. The organic water supply section provides water purification and storage of water supply points using approved water sources.

d. Planning Considerations. The focus of Army planning has been to provide water support in a desert environment. Care must be taken in establishing total requirements for mobile operations in a desert, especially with regard to supply and means of distribution. Quartermaster water units have adequate capabilities for water treatment on temperate, conventional battlefields. However, additional water purification capacity is required to provide for greatly increased requirements in hot, arid theaters and on integrated battlefields. Augmentation of water supply units produces a significant increase in transportation distribution requirements.

8-15. Repair Parts (Class IX) Supply Planning

a. Repair parts (class IX) supply and maintenance related class II supply must allow for the adequate flow of combat essential items, without building up unnecessary stocks. Key elements include combat essentiality and the ability to receive, handle, and move the supplies.

b. Some class IX and selected class II items such as handtools, small test equipment, and hardware are eligible for routine air shipment to selected Supply Support Activities (SSAs) under the ALOC distribution system. ALOC SSAs normally "pull" these items by requisition under the Direct Support System (DSS) from CONUS. The goal in peacetime, as in wartime, is to maximize throughput to reduce handling at intermediate transshipment points and shorten overall order ship time (OST). The goal is 80 percent throughput ship-

ments to the SSA, from CONUS supply sources. Heavy tonnage items such as track vehicle track, artillery gun tubes, engines, tires and batteries are normally shipped by sea.

c. The items within unit ASLs are determined by the type of units and equipment to be supported. The organization of a particular division is fairly stable, but since they support on an area basis, nondivisional DSUs need to know what units or type units are to be supported so that ASLs can be constituted. It is imperative that the logistics portion of Army component supporting OPLANs assign supporting responsibilities for general support units (GSUs) and nondivision DSUs prior to deployment so they can make up their accompanying ASLs. Assistance in developing the ASL/PLL can be obtained from AMC item managers and the US Army Materiel Readiness Support Activity (MRSA).

d. While ALOC eligible materiel is normally pulled by requisition from CONUS PWRS and pre-planned resupply, package shipments may be authorized by the TA commander where single line requisitioning cannot be accomplished. These packages should not exceed 1,500 lines per commodity area. The NICPs and SICCs, together with the Army component planning agent, should develop preplanned supply packages and pre-position requisitions for these class IX and II items as emergency resupply packages in the event of breakdown of computer capability and/or communications lines.

e. Published field manuals in the 42 series provide reference data to logistics planners and item managers. These manuals assist in forecasting mission essential maintenance and associated repair parts requirements for contingency operations and war reserve planning. They provide information on mission essential maintenance operations (MEMO), mission essential repair parts, and repair part quantities for selected combat significant equipment.

f. The Army Standardized Combat Prescribed Loadlist and Authorized Stockage List (combat PLL/ASL) Program also establishes mandatory repair parts stockage in support of TOE units. The mandatory parts lists (MPL) are published in DA pamphlets in the 710-2 series and are keyed to individual TOE numbers.

Section III. MAINTENANCE PLANNING

8-16. Introduction

a. General. Materiel maintenance is all action taken to keep materiel in a serviceable condition, restore it to serviceability, or update and upgrade its functional utility through modification. It includes inspection, testing, servicing, classification as to serviceability, repair, modification, overhaul, and reclamation. The materiel maintenance functions, performed as an integral component of CSS, include the plans and operations involved in maintaining materiel and determining requirements for evacuation. The maintenance support unit mission may include the responsibility to provide repair parts resupply and operational readiness float (ORF) support to operating units. At the Intermediate (GS) maintenance level, the maintenance support unit mission includes the repair of certain items for return to the supply system. Inherent in the maintenance mission is a dependence on the capabilities and responsiveness of using units and maintenance units in the corps to discover and report deficiencies in materiel and to recommend corrective action through appropriate channels to AMC.

b. Materiel Maintenance in a Tactical Environment. Materiel maintenance activities in the field are those internal to theaters of operation and/or those performed by and in support of the missions of deployable commands, organizations, and units in CONUS or those deployed in oversea areas. These maintenance activities sustain the operational readiness of the force. They activate and operate the intermediate maintenance support system, in accordance with the plans and equipment publications prepared by a national maintenance point (NMP), to maintain in a serviceable condition, materiel sufficient to satisfy prescribed operational requirements.

c. Maintenance Management.

(1) Maintenance management is the process of establishing maintenance objectives and the planning, obtaining, organizing, directing, coordinating, controlling, and evaluating the use of resources to accomplish these objectives.

(2) Maintenance management includes forecasting the maintenance workload and determining the personnel; training; tools; test, measurement, and diagnostic equipment (TMDE); calibration equipment; facilities; funds; spares and repair parts; other maintenance supplies; technical data; and management information and procedures needed to effectively and economically accomplish that workload on a timely and responsive basis.

(3) The periodic evaluation of maintenance concepts, policies, doctrine, plans, and procedures to insure that they provide the most effective maintenance support for technical equipment is a function of maintenance management. The technical supervision and management of major maintenance programs and activities are included in these evaluations.

(4) A primary function of maintenance management at the unit maintenance level is to insure that adequate time is allocated and/or scheduled for the performance of maintenance training and maintenance operations, particularly those involved in the performance of preventive maintenance (PM).

8-17. Objectives of Maintenance

The overall objective of materiel maintenance is to support the combat readiness and effectiveness of the Army by sustaining weapons and equipment in a mission ready condition as effectively, responsively, and economically as possible.

8-18. Levels of Maintenance

The Army Maintenance System consists of three levels of maintenance operations; unit, intermediate, and depot, which are described in AR 750-1 and discussed in paragraphs *a*, *b*, and *c* below. The purpose of this categorization is to relate maintenance to other military operations; provide organization to the system for maintenance; facilitate assignment of maintenance responsibilities to specific levels of command; and permit orderly and efficient distribution of maintenance assets. The mission of a particular unit or organization, the complexity and bulkiness of the items of equipment, the operational location of the unit, and requirements for constant readiness dictate the allocation of maintenance tasks to repairs authorized at the unit or organization. Maintenance allocation charts for each piece of equipment assign functions and repair operations to the lowest appropriate level.

a. Unit Maintenance. Unit level maintenance is performed by the operator, crew, and company/troop or battalion/squadron/brigade maintenance personnel. It is characterized by quick turn around repair by replacement, minor repairs, and performance of scheduled services. If the repairs are beyond the capability of organic maintenance personnel, the units request support from the intermediate direct support maintenance company. Unit level maintenance maintains a combat pre-

scribed load list consisting of the mandatory parts list and selected demand supported items.

b. Intermediate Maintenance. The intermediate maintenance level has two orientations, direct support and general support.

(1) The intermediate (direct support) maintenance (IDSM) is performed in support of the user. The focus of intermediate direct support maintenance is mobile support as far forward as possible, repair by replacement, and maintaining high volume, fast moving operational readiness floats.

(a) Divisional intermediate (direct support) maintenance units provide dedicated support to brigades and battalions including repair of selected high usage components.

(b) Nondivisional intermediate (direct support) is performed in support of the user on an area support basis. When performing a backup support mission, the unit is assigned highly mobile augmentation teams.

(c) Maintenance tasks at the intermediate (direct support) level include battle damage assessment, diagnosis, fault isolation, repair by replacement, repair of selected high usage components in support of the repairable management program, and establishment and operation of maintenance collection points (MCP) and base maintenance areas. MCP are located where skills, tools, TMDE, and repair parts are concentrated to quickly repair critical equipment for return to the using unit and evacuation or salvaging of nonrepairable equipment.

(d) Intermediate (direct support) maintenance units maintain shop stock, if not colocated with ASL, for support of assigned maintenance missions. Units supporting combat brigades and regiments maintain combat authorized stockage lists to support the items stocked in supported units' combat PLL. Selected companies of the divisional maintenance battalion maintain combat ASL to support the combat PLL of the divisional units and the ASL of the forward maintenance companies. Nondivisional intermediate (DS) maintenance units assigned to corps and EAC provide repair parts to customer units in the geographical support area.

(2) Intermediate (general support) maintenance (IGSM) units are located at echelons above corps and perform maintenance in support of the theater supply system through the repair of assemblies, components and modules, repairable items, printed circuit boards (PCB), and ORF. Intermediate (general support) maintenance units are job or production line oriented for repair of class VII and IX items. Maintenance tasks at this

level include diagnosis, repair of assemblies, components and modules, PCB, and maintenance of theater reserve stocks. Repair parts stockage in these units is limited to items required to support assigned maintenance missions.

c. Depot Maintenance. Depot level maintenance in support of the supply system is performed by AMC depots or activities, contractors, and host nation support personnel. Depot maintenance is performed in fixed facilities in CONUS and the theater of operation, and is production line oriented. Repair parts supply support for depot maintenance is limited to items to support assigned maintenance missions.

8-19. Effect of Maintenance Concept on Logistics Planning

a. The TA commander is responsible for determining maintenance support requirements; formulating plans and policies for provision of maintenance; and allocating maintenance units to major subordinate commands based on requirements, priorities, and availability of maintenance units. The TA commander's OPLAN should describe the concept of maintenance to include size and composition of ORFs, cannibalization policies, recovery and evacuation policies, night operations, time limits within which repairs must be made at intermediate maintenance levels, assignment of maintenance responsibilities and the role of AMC in the theater. The OPLAN should also include the concept of maintenance in a nuclear, biological or chemical environment. The TA commander is responsible for developing and maintaining a self-sufficient military capability and capacity for the intermediate level maintenance of the combat, combat support, and combat service support elements of his commands.

b. The maintenance concept in a theater without an established US base (such as Southern Africa or Southwest Asia) will differ widely from the concept for a theater where there is an established US base (such as Europe). In the former, initial maintenance efforts would be confined to replacement of modules, components, and assemblies obtained through repairable management procedures. There would be no repair of the unserviceable modules, components, or assemblies until such time as a COMMZ or possibly a corps rear area (for an undivided theater) is established. Intermediate direct support maintenance units would be employed in a forward support role. Cannibalization would be a significant source of repair parts to keep maximum numbers of critical combat items operational. The size and composi-

tion of the operational readiness float would be larger. Definite plans and procedures for the recovery, technical inspection, and evacuation of major items, components, and assemblies that cannot be repaired forward will be established. For repairable, combat essential items, plans should indicate in-country repair facilities (other US service, allied, host nation, or commercial) or evacuation to CONUS or other offshore bases. After a GS base and COMMZ have been established, more time-consuming maintenance can be performed. Maintenance in support of the supply system will normally be performed by echelons above corps IGSM units or other facilities. At this time, IGSM units will perform repair of assemblies, components and modules, DX items, printed circuit boards and ORF.

(1) In Europe the maintenance concept would be vastly different because mobile, semifixed, and fixed maintenance facilities (to include some depot capability) are in existence. Interservice support agreements, agreements with allies, and host nation agreements are in effect or being promulgated as are commercial contracts. In effect, the maintenance system is already established. In time of conflict it would require some modification and expansion.

(2) In Korea, while facilities are not as complete and sophisticated as in Europe, a maintenance system does exist. It can be expanded and can exploit the capabilities of offshore bases in the area to reduce turnaround time.

(3) Planning will also differ in either scenario (established or nonexistent US base) if the forces entering the theater are inserted tactically or administratively. In the former, the proper selection and scheduling of units and the development of resupply and personnel replacement packages is paramount. Many units may be deployed in fragmented configurations. Accompanying supplies will be limited as will resupply due to constraints on transportation and line of communication facilities. The force must operate with what it brings in. If the forces are inserted into an area administratively, unit integrity can usually be maintained and larger quantities of supplies can accompany the troops. Scheduling and phasing of the units need not be so finite and personnel and equipment losses should not be so great as with a tactical insertion.

c. In summary, maintenance planning for deploying forces would consider:

- (1) A short intermediate DS evacuation policy.
- (2) Limited class IX stockage.
- (3) Reliance on DSS and ALOC for class IX support.

(4) Emphasis on modular/component/assembly repair and/or major item replacement.

(5) Repair of only critical items.

8-20. US Army TMDE Support System

a. General.

(1) The US Army Materiel Command (AMC) is responsible for approval and publication of Army policy pertaining to TMDE and measurement standards research, development and acquisition. The Deputy Chief of Staff for Logistics HQDA (DCSLOG) is responsible for approval and publication of Army TMDE support policy and general staff supervision of the implementation of such policies by the major field commands.

(2) AMC is also responsible for developing, establishing, and maintaining the Army TMDE support system. The responsibility of supervising this system lies with its subordinate activity, US Army TMDE Support Group (USATSG), Redstone Arsenal, Alabama.

(3) The USATSG is responsible for providing Armywide command and control of specified AMC TMDE support activities, technical direction, and insuring logistics support for the Army TMDE support system. AMC activities under the command and control of USATSG with geographic area TMDE support assignments, are responsible for providing calibration and repair service to US Army organizations within their assigned geographic areas for general purpose and selected special purpose equipment. Intermediate maintenance units are responsible for providing calibration and repair service to units supported for special purpose TMDE as designated in TB 43-180. Organizational units are responsible for securing support service for their TMDE.

b. Policies.

(1) The Army TMDE support system is based upon the policies and responsibilities in AR 750-25 and the procedures in TB 750-25. The responsibility for general staff supervision of the Army-wide TMDE program is assigned to the Deputy Chief of Staff for Logistics, HQDA. The US Army Materiel Command manages, directs and controls the Army-wide TMDE Calibration and Repair Support (C&RS) program. AMC will maintain the USATSG to:

(a) Exercise Army-wide technical control of the TMDE support program.

(b) Exercise command and control of all maintenance battalions (TMDE), maintenance companies (TMDE), and Area Calibration and Repair Centers (ACRCs).

(c) Develop mobilization, operation, and logistics plans to insure TMDE C&RS during wartime for all active and reserve components.

(2) IAW AR 750-25, AMC is responsible for TMDE support planning for contingency purposes. That planning responsibility is further delegated by regulation to the US Army TMDE Support Group (USATSG) with HQ at Redstone Arsenal, AL.

(3) Although HQ, AMC continues as the MACOM planner, a direct line of communication between responsible Army component command planners and the USATSG will be established to effect detailed TMDE support planning for contingency operations. Direct communication on exercise or real world Time Phased Force Deployment Data (TPFDD) requirements and employment of forward deployed TMDE support assets is necessary to insure that adequate support is available for inclusion in AMC LOGPLANS in support of approved Army component command OPLANS as required.

(4) Because the USATSG has a worldwide support mission in peacetime, there are forward deployed subordinate elements in USAREUR, USAEIGHT, USARJ, WESTCOM, and SOUTH COM as well as CONUS. These elements are battalion level or lower, and as such, are not staffed for an extensive planning mission. Taskings related to TMDE support planning or MACOM-level exercise employment of TMDE assets will be directed to USATSG. This direct communication should preclude unnecessary shortfalls and after the fact efforts at contingency planning for TMDE support.

(5) It is imperative that the USATSG be included in the distribution of any data reflecting TPFDD assignments early in the planning cycle. This information will allow the USATSG to project the required support based on their analysis of TMDE requirements in the deploying units and subsequent assignment of that support to the TPFDD. The only data base that can provide the necessary finite information is maintained by the USATSG.

(6) Operation of TOE TMDE support organizations is addressed in FM 29-27, Calibration and Repair Service in the Theater of Operations, 15 March 1985. As specified in FM 29-27, the TOE structure for the Maintenance Battalion (TMDE)

and Maintenance Company (TMDE) does not allow for operations as autonomous ATSTs. They are dependent upon the unit of attachment for messing support, communication support, POL support and maintenance of organic vehicles. Their defensive capability is limited to small arms. The host unit is responsible for providing the support required by the battalion and/or company elements and integrating them into the defensive plans.

(7) Communications relative to TMDE support planning will be directed to CDR USATSG, ATTN: AMXTM-OR, Redstone Arsenal, AL 35888 or by message address to: CDR USATSG REDSTONE ARSENAL AL//AMXTM-OR// with INFO CDR AMC ALEX VA//AMCTM/AMCRE-P//.

c. Responsibilities.

(1) Supported Army component commands will insure the USATSG is included in formulation of the TPFDD to insure early identification if applicable of Area TMDE Support Teams (ATSTs). It is incumbent upon Army component command planners to recognize that TMDE support is provided by AMC activities. That support is not organic to other Army maintenance elements, and must be separately analyzed and identified. A direct line of communication between the USATSG and component commands is essential to the provision of adequate TMDE support in wartime.

(2) The CDR, USATSG will insure ATSTs are deployed in sufficient number to support the units troop listed in applicable OPLANS. The number and configuration of ATSTs deployed is contingent on the TMDE density in the area of operations. Deploying USATSG subordinate elements will be prepared for overseas movement PERAR 220-10. Elements attached to active Army divisions will be processed for overseas movement by the division to which they are attached.

d. Procedures. The ATSTs are mobile and air transportable (when required) to support unit sites. Each team is equipped with tools, one set of secondary transfer standards, TMDE repair set, repair parts, and expansible vans in which equipment is transported and calibration and repair functions can be performed. The vans when expanded, provide a suitable work area for TMDE repair and secondary transfer calibration operations. Details on the expansible van are found in TM 9-2820-260-10.

Section IV. TRANSPORTATION PLANNING

8-21. General

a. Transportation planning is determining what is to be moved under varying constraints and selecting a mode of transportation to best fulfill a requirement. While most of the time-consuming detailed computations can be accomplished in minimal time with the aid of a computer, the planner must interpret and evaluate the computer output.

b. Transportation national emergency planning is centrally coordinated by the Office of Emergency Transportation (OET) of the DOT. The mission of this office is to develop preparedness programs for all modes of commercial transportation required to move passengers and freight for essential civil and military needs during emergencies, and develop controls of transportation resources to be applied in the degree necessary commensurate with the emergency. When controls are applied, the carriers manage their operations, industrial traffic managers perform normal functions, and the normal (shipper-carrier) relationship prevails subject only to the applied controls. Industry is expected to provide continuity of management protection of personnel and facilities and restoration of damaged lines. The Government would increase its control to insure continuous support of the Armed Forces should industry not be capable of providing the service.

c. The Deputy Director, J-4 (Strategic Mobility) of the JCS is responsible for the analysis, evaluation, and monitoring of all aspects of strategic movement planning and operations. Further responsibilities include joint transportation planning, policy, and guidance, including matters of joint and international transportation operations, the administration and support of the Joint Transportation Board (agency of JCS) and its elements. He also serves as chairman of the board and acts on behalf of the JCS for transportation matters. The Director of Army Transportation also serves on this board. Planning guidance, contingency plan evaluations, the Five-Year Defense Plan, and other plans that involve transportation directly or indirectly incorporate the systems analysis techniques and procedures for computer usage.

d. The Military Traffic Management Command (MTMC) is responsible for emergency highway needs for the DOD and for taking appropriate action for integration of these needs into public highway programs. Future planning must consider extensive disruption of transportation resources by a major nuclear attack. In such cases, controlled use of the remaining transportation facilities

would be planned to support the needs of the Armed Forces, and restoration of the industrial activity as early as possible.

e. MTMC is responsible for a program called Contingency Response Program (CORE) which provides DOD service support and priority prior to and during contingencies and mobilization. The action arm of the program is the CORE team comprised of key senior officials of DOD, other federal agencies, and the commercial transportation industry, all of whom have security clearances. CORE quick reaction procedures utilized by the team significantly reduces the time required to muster civil rail, motor, bus, and air assets to meet DOD priority requirements. Authority of existing law in the Defense Production Act of 1950 (*as amended*) insures DOD transportation service priority if required to meet contingency needs.

f. The present concept of military participation in regulating US highway traffic during emergencies is that each CONUS Army commander will represent all services at State traffic centers in his area. State and local highway personnel, due to their familiarity with field organization and their facilities usability under varying conditions, are vital to any plan for maintaining highways. The MTMC provides national level interface between the US Army area commander and the US DOT.

g. The MTMC provides planning support to the Armed Forces on usage of commercial and military resources, to include DOD freight railway interchange fleet and the operation of common-user US ocean terminals. The operation of the railway interchange fleet involves control and maintenance of government-owned railcars used to augment commercial capability. In addition, the Army looks to the MTMC for strategic planning data required in the Army's planning mission. MTMC is responsible for determining CONUS transportation capability, analysis of emergency military requirements, and preparation of comprehensive CONUS commercial transportation movement plans. It is also responsible for guidance and assistance to the Army in the preparation of other joint, or unilateral plans where CONUS movements are involved. The command assists carrier associations and carriers in the development and coordination of their emergency plans as they affect the military departments and in the development and maintenance of up-to-date agreements with carrier associations.

8-22. Principles of Military Movements (Transportation)

The principles of movements (transportation) are applicable to all military transportation services. They remain constant in peace or war regardless of whether an automated or a manual system of operation is used. These are also principles to be addressed regardless of the planning level.

a. Centralized Control. Control of movements will be centralized to the highest level at which it can be adequately exercised. This means that centralized control must be exercised by the commander charged with providing total logistics support. He must be able to establish priorities, allocate critical resources, and identify and correct deficiencies. In carrying out this principle, TA and corps commanders are assisted by their respective support commanders (Transportation Command (TRANSCOM) and COSCOM). These organizations command most of the agencies involved in accomplishing movements. Movements are coordinated by the Movements Control Agency (MCA) at the TA level and Movements Control Center (MCC) located within the COSCOM headquarters.

b. Regulated Movements.

(1) The introduction of Automated Data Processing equipment into supply and transportation operations and the requirements to maintain and support highly mobile forces will greatly increase the requirement and capability for regulating movements beyond that experienced in any other war in which the US has been involved. Most supplies are moved from theater army General Support supply activities (and in some cases from ship side) to COSCOM GS supply activities or to Division Support Commands (DISCOM) direct support units. As a consequence, transportation equipment is constantly moving into and within the corps area, and detailed regulation and coordination are required to prevent congestion and conflict of movements.

(2) It is probable that in any future war US forces will have to share the available airfields and road, rail, and inland waterway capabilities with allied forces and civil commerce. In this case, only careful regulation of movements and close coordination can insure an efficient transportation system.

c. Fluid and Flexible Movements. The transportation system should provide an uninterrupted flow of traffic that adjusts rapidly to changing situations. A major goal of CSS is maximum throughput of supplies to the COMMZ forward area and the corps rear area thereby reducing rehandling. Attainment of throughput goals and

effective use of all transport are impossible unless the capability exists throughout the transportation system to divert, reroute, and exchange or to take whatever action necessary to insure continuous movement of supplies to destination.

d. Minimum Use of Carrying Capability.

(1) Transportation assets which are not used cannot be stored for later use. Transportation assets are normally in short supply and advance planning can prevent shortfalls by anticipating future requirements. Tactical consideration may preclude complete adherence to this principle (for example, vehicles designated and held for the movement of special weapons or aircraft delivering unit loads in combat support). This maximum-use principle permeates the entire field of transportation movements. It is evidenced by the three principles previously discussed, but the fourth principle is aimed at full use of the components of the system.

(2) Requirements fluctuate for transportation within a theater or a segment of the theater, depending on the tactical situation. Proper use must be made of each transport mode in accomplishing the commander's objectives. Air transport will be employed if speed of reaction is paramount or terrain features prohibit the use of other modes. Motor transport, with capabilities for wholesale and retail deliveries, complements air and the fixed modes of rail, inland waterways, and pipelines.

(3) In application of this principle of movement to the selection of transport mode, the following guidelines apply:

(a) The most economical mode for the complete movement will be used, consonant with the mission of the command; otherwise, that mode's available capability will be used as far forward as possible.

(b) Rehandling of cargo will be minimized or eliminated whenever possible.

(c) Backhauls and crosshauls will be avoided whenever possible.

(d) All available transport equipment necessary to fulfill known requirements will be allocated.

8-23. Planning for Support of Military Operations

a. Transportation planning in support of a unified commander's OPLAN addresses both inter-theater and intratheater movement and reception of personnel, materiel, and equipment from point of origin to destination. In addition, the competing

requirements for limited strategic lift resources, mobility support facilities, and intratheater transportation assets must be assessed in terms of impact on mission accomplishment; priorities must be established; and a movement program must be prepared in light of both movement constraints and the concept of operations. The movement program is the basis for development of detailed transportation tables and schedules used in the implementation phase of the plan.

b. The payoff in transportation planning lies in the timely delivery to planned destinations of both effective combat forces and the means for their sustained support.

(1) Effective combat forces include both unit personnel and unit-related supplies and equipment.

(2) Sustained support includes support forces, replacement and filler personnel, resupply and buildup, and construction personnel, materiel, and equipment.

c. At the outset of transportation planning, all requirements data are assessed in terms of point of origin and destination. Having determined what is to be moved, requirements (e.g., force, personnel, and cargo increments) are sequenced in order of desired arrival at destination and the mode of transportation is selected; ports of debarkation (POD) and intermediate PODs are determined; time-distance factors are applied; departure date is reckoned; conflicting requirements for limited transportation assets and mobility support facilities are reconciled; and the movement program is tested for feasibility.

d. The objectives of transportation planning are to:

(1) Aggregate and sequence by destination and required delivery date (RDD) the movement requirements of all participants in the plan.

(2) Establish the lift mode, port of embarkation (POE), departure date, POD, arrival date, and priority of each force, personnel, and cargo increment.

(3) Assess lift allocations and the capacity of mobility support facilities for adequacy and identify shortfalls and limiting factors.

(4) Identify enroute support requirements of the transportation operation agencies (TOA).

(5) Provide data for the further refinement of the Time-Phased Force Deployment List (TPFDL), time-phased supply and equipment lists, and the Base Development Plan (BDP).

(6) Document transportation requirements data in a format that can be tested for feasibility.

(7) Develop a feasible movement program.

(8) Produce time-phased transportation requirements data.

e. The main elements of transportation planning are:

(1) *Requirement Listing.* Force, personnel, and cargo requirements that need movement, along with related movement characteristic data relating to all military forces which are integrated, sequenced by RDD and priority within RDD, summarized by destination, and compiled into a single time-phased listing.

(2) *Lift Mode to Destination.* The selected lift mode, or modes, identifies the type of transportation to be used in the movement of the force, personnel, or cargo increment between point of origin and destination.

(3) *POE Determination.* A POE is a geographic location (airport, seaport, land line terminal, or other area) at which strategic movement originates. The POE and the point of origin of a force, personnel, or cargo increment may be colocated or may be separate locations.

(4) *POD Determination.* A POD is a geographic location (airfield, seaport, land line terminal, or other area) at which a leg of a planned movement ends. Destination and POD may be colocated or may be separate locations.

(5) *Timing.* Transportation planning is concerned with the timely delivery of forces and the means for their sustained support. Flexibility in the movement program is the key to scheduling. To achieve this, timing of the beginning and ending of each leg is expressed in terms of earliest and latest dates for each force, personnel, and cargo increment. The basic constraints are:

(a) RDD at destination.

(b) The time when force, personnel, and cargo increments are available for movement at their point of origin.

(c) Time/distance factors between point of origin, POE, POD, and destination.

(d) Throughput capacities of related mobility support facilities.

(e) The capacity and security of staging bases and supply depots.

8-24. Transportation Planning

a. As discussed in chapter 5, transportation planning is an integral part of the Joint Operations Planning System (JOPS). Since the function of transportation is the movement of men, materiel, and equipment from origin to destination, plan-

ners must analyze and plan for the entire system, both intertheater and intratheater.

(1) Planning for the movement of troops, equipment, and supplies from CONUS or another theater to a theater of operations is a strategic mobility problem. Determination of the requirements (i.e., force structure and time-phasing of the force into the theater of operations) is the responsibility of the supported commander. Determining the availability of airlift and sealift resources to meet the transportation requirements is the responsibility of the Military Airlift Command (MAC) and Military Sealift Command (MSC). Any shortfalls in lift capability must be addressed and ultimately resolved by the supported commander. Planning for the movement of units and accompanying supplies from a CONUS installation to the POE is the joint responsibility of the unit commander, the installation transportation officer, and MTMC.

(2) Planning transportation, from the POD forward within the theater, is the responsibility of the supported commander. If the supported command happens to be a joint command, the commander will normally assign the responsibility for intratheater transportation planning to one of his service component commands. In most cases, this will be the Army component. If the Army component is a TA, the TA Deputy Chief of Staff for Logistics, will normally perform the transportation planning. If the Army component is of corps size, the COSCOM ACofS, Transportation, performs the planning.

(3) The transportation planner analyzes the commander's concept of operations and the terrain of the theater to determine what transportation requirements will be needed to provide adequate intratheater support. From this analysis, the transportation planner will derive two important inputs for the contingency plan. First, the type and quantity of transportation units needed in the theater; and second, identification of needed improvements to the existing intratheater transportation network that should be included in the BDP.

(4) The uniqueness of transportation planning for contingency plans is that the entire transportation system from within CONUS to the forward edge of the battle area (FEBA) must be addressed.

b. Transportation planning for current operations is the routine management planning necessary to insure that day-to-day flow of men and supplies is timely and efficient. Planning is based on those assets that are physically available. This planning includes revision of procedures to compensate for losses in transportation capability or to

take advantage of circumstances which permit more efficient working arrangements. This planning is normally performed by the various MCCs within the theater.

c. Transportation planning for future operations:

(1) Includes planning for new operations and for new phases of the current operations. This planning normally is performed by the ACofS, Transportation, of the COSCOM.

(2) The plan for a new operation requires careful and comprehensive preparation. Transportation units may have to be relocated, new transportation networks may need to be opened up, and the transition period may be critical. Coordination with the other staff planners, both operational and logistical, will be continuous.

8-25. The Transportation Planning Process

Regardless of the type of transportation planning, the planning process will be basically the same. First, determine what must be moved. Second, determine what transportation resources are available. Third, balance requirements against resources. Fourth, determine shortfalls, critical points, and recommend priorities. Fifth, and most important, coordinate the plan with all affected. The transportation planner must determine the requirements of the supported units and then attempt to develop a transportation network to satisfy these needs.

a. Determining Requirements.

(1) Each requirement for troops or supplies generates at least one requirement for transportation. Initial transportation requirements can be expressed in terms of tonnage (or number of personnel) and distance. In later stages of planning, the tonnages become classes of supply and even distinct items and distances become routes between specific origins and destinations.

(2) The responsibility for providing adequate transportation support for the operation rests with the transportation planner who estimates total requirements based on the average supplies required for the supported forces and the average distances involved in the phases of the operation. This estimate serves as a point of departure and as a general check on the realism of requirements submitted by users to recognize every supply or personnel action as a transportation requirement and to refine those requirements as early as possible.

(3) Some requirements may be within the capability of transport organic to the requesting

unit. The planner must determine the extent of such capabilities and urge their utilization.

b. Determining Resources. An assessment of transportation resources involves consideration

- (1) What type transportation units are available.
- (2) Characteristics and capabilities of each mode of transport.
- (3) Capabilities of available civilian transport, based on a survey of facilities, inspection of equipment, and agreements negotiated with civilian transportation operators.
- (4) The availability of PW and local labor to supplement manpower resources.

c. Balancing Requirements and Resources

(1) The process of balancing requirements and resources determines if the transportation capability is adequate to support the operation. It also establishes the workload for each segment of the transportation service. This is the most time-consuming portion of the planning process.

(2) Providing complete transportation support requires consideration of factors other than the necessary operating units. The planner provides for adequate command and control by organizing units according to their missions, proposed locations, and area of coverage. He coordinates with planners of other services to insure that their plans include the necessary capability for support to the transportation units. He makes recommendations as to the location of supply and service installations in accordance with their requirements for transportation.

(3) A composite statement of total requirements for transportation expedites the planning process. Each planner selects the format that he finds most usable. One may use a chart listing of requirements, showing origin, destination, RDD, weight, quantity, and class of supply for each shipment.

(4) The process of establishing workloads for each transport mode varies according to the phase of operation. In the usual situation, the plan for the initial phase should provide sufficient motor transport for all cargo and personnel movements. Though some priority items will move by air, this quantity normally will be only a small percentage of the total supplies.

(5) Workloads are computed individually for each transport mode according to the characteristics and capabilities of the operating units of that mode. The final plan, however, must combine the units and operations of all modes into a single, integrated transportation system.

(6) During actual operations, the theater commander allocates a portion of the available airlift to TA for requirements usage. For planning purposes, however, air movement capacity is an assumption based on coordination with Army aviation and Air Force planners. This assumed capacity seldom exceeds the requirement for movement of priority cargo. If there is an excess, planners should use it for nonprogramed priority movements. Army transport aircraft capacity seldom exceeds the amount required for DS of combat operations. Therefore, plans should not provide for routine movements by air of other than priority cargo.

(7) In only a few areas of the world are there extensive inland waterway systems compatible with transportation requirements. Inland waterway systems are relatively vulnerable to enemy action and sabotage, and are difficult to restore to usefulness.

(8) The planner must be certain to include all types of workloads, such as: successive, direct, retrograde shipments of some cargo; documentation for rehandling, rewarehousing requirements, augmentation of unit's transportation, assistance to medical evacuation plan; and requirements to support allied and civilian organizations.

d. Determine Critical Points.

(1) In the transportation planning process, it is important to analyze the system and try to identify critical points such as facilities being used at maximum capability; a critical mode or segment of the system; or a critical time period when the entire system is taxed to its limit.

(2) Accompanying this critical point determination is an analysis of what alternative plans or control measures would alleviate possible bottlenecks. This builds flexibility into the system.

e. Coordination. Complete coordination among all planners is mandatory to insure integrated support. Since the original guidance is seldom valid throughout the planning period, constant coordination with the other staff planners on changes to the mission, commander's concepts, assumptions, intelligence, policies, priorities, allocations, locations of facilities, and other topics necessary to keep planning current, is an absolute necessity.

f. Flow of the Planning Process. The planning process is not complete until it is implemented. It should follow this logical flow.

Determine requirements → Determine the available transportation resources → Balance resources with requirements → Determine the critical points → Coordinate and refine the plan.

8-26. Transportation Planning Factors

a. The basis for planning transportation support is the size force to be supported and the schedule for movements of the force. From this the number of personnel and the tonnage of equipment and supplies to be moved each day is determined. The Time-Phased Transportation Requirements List (TPTRL) indicates the number of personnel and tonnages (short tons and measurement tons) of supplies and equipment to be moved each day.

b. Initial estimates of personnel and cargo to be moved can be obtained from the Type Unit Characteristics (TUCHA) data of type units in the Time

Phased Force and Deployment Data (TPFDD). Non-unit personnel (replacements) and non-unit cargo (resupply) data is also obtainable from the TPFDD. The FORSCOM Computerized Movement Planning and Status System (COMPASS) can be used to provide Army unit notional data as well as current movement data for Army units. Capacities of transportation facilities can be obtained from Joint Operation Planning System (JOPS) files and from AR 55-357, Terminal Facilities Guide. The Army Force Planning Data and Assumptions (AFPDA) provides current transportation planning factors for use in large scale planning.

Section V. FIELD SERVICES PLANNING

8-27. General

Services are those general activities that support the missions and functions of Army units, installations, and facilities. CSS services include logistics or field services and personnel service support. Field service functions include laundry, bath, clothing exchange, food services, bakery, textile renovation, graves registration, fumigation, clothing sales, airdrop, and general duty labor. In the initial phases of combat, field service functions are performed by such units as the field service company, GS, and the supply and service company,

DS. In an established theater, many of these functions are subject to interservice support, cross-service agreements, or can be performed by host nation or contractors. As the area of operations enlarges and a separate COMMZ emerges, more and more services will be performed by the single service concept, host nation, and/or commercial activities. For planning purposes, the types and capabilities of the units that provide these services are shown in chapter 17, FM 101-10-2. Graves registration services are especially sensitive and are usually controlled by the supported unified commander.

Section VI. FACILITIES PLANNING

8-28. General

In an oversea area facilities such as buildings, airfields, piers, access roads, railway spurs, water towers, and beacons, are usually grouped together in relatively fixed locations referred to as bases. In an established theater such as in Europe and the Pacific, these various facilities are grouped together in installations in much the same manner as in CONUS installations. The locations are fixed and the buildings, roads, utilities, etc., are of permanent or semipermanent construction. The planning and programing for the development of these facilities may be carried out similar to those for CONUS installations under the Installation Master Planning Process (AR 210-20) and the Military Construction Army Program (AR 415 series). Others identified in unified command OPLANs are the result of civil engineering support planning (CESP) also referred to as base development (BD) planning. It is this latter type planning which will be discussed in this section. These OPLANs identify the major facilities (ports, airfields, storage areas, troop camps, hospitals, security facilities,

PW camps, etc.) to be repaired (battle damage) or to be constructed in support of the OPLAN. Basic engineering planning data are contained in chapter 6, FM 101-10-1.

8-29. Civil Engineering Support Planning

a. Base development (BD) is the acquisition, development, improvement, and expansion or rehabilitation of the facilities and resources of an area or location for the support of forces employed in military operations or deployed in accordance with strategic plans.

b. BD is provided for in a CESP which is an essential element of the joint theater OPLAN. It is analogous to the master plan and becomes the governing instrument for the development of bases. The BDP is developed to insure the timely availability of construction forces, materiel, and facilities necessary to support the OPLAN. The development of the BDP as part of the OPLAN is discussed in paragraph 5-14f.

c. The period of time during which a base is to be used determines the standards to which it will be constructed. The Joint Operations Planning Procedure and JCS Publication 3 define these standards.

d. The doctrine and procedure of BD planning are prescribed in FM 31-82. Construction facilities and responsibilities are discussed in chapter 13, FM 100-10.

e. The BDP must insure timely availability of facilities required to support the operation. Careful detailed planning of a base requires time and effort, but it is necessary to conserve resources and operate the base efficiently. The many details make it highly desirable that an experienced staff be employed in preparation of the plan. Advantage should be taken of experience gained during development of other bases in similar environments. When a given staff must be augmented for planning to support imminent operations, it is preferable to use personnel who later will be involved in actual development and operation of the base.

f. BD planning is analogous in many ways to city planning or the master planning of permanent military installations. Many of the same planning principles apply. The mission of the support base is the controlling factor in determining the extent of the development and the schedule for completing the facilities to be provided. In determining what facilities must be provided, planners consider in-country facilities and those of neighboring countries that host countries are willing or able to provide. This includes military assistance and economic aid facilities which can be made available by agreement with the host country. Repair of war damaged facilities is accomplished before new construction is initiated. Local manpower, construction equipment, supplies, and materials are used to the extent feasible to reduce the requirements for US construction troops and materials.

g. Construction forces and materiel should be scheduled into staging and objective areas so as to permit timely completion of essential facilities. The early deployment of construction forces, as with other support forces, tends to develop a snowball effect; i.e., they require support for their own personnel and equipment. Moreover, construction materiel requirements usually will place heavy demands on transportation resources. Trade-offs often will be required between operational and logistics considerations. Hence, it is important, particularly in the early phases of an operation, to hold new construction to an absolute minimum.

h. Areas suitable for base support complexes may be limited in size or may be remote from

tactically desirable areas. Also, space should be allocated in accordance with priorities established by the theater commander, with due regard to needs of the local populace and allied forces. Potential sites may be reserved for high-priority installations, such as airfields. User agencies should evaluate their situation promptly and release unsuitable or unneeded sites.

i. Construction programs conducted on a crash basis in foreign countries require special considerations in acquisition of real estate. Such acquisition and use of land by US forces are predicated on government-to-government agreements that designate the rights and responsibilities of each government. Immediate contact with potential host governments to ascertain their receptiveness to an expanded military presence and their support of US military real estate needs is essential. It cannot be assumed that the host government will expedite acquisition of real estate to meet US military requirements.

j. Various aspects of vulnerability will affect planning of the base. If the enemy possesses a nuclear capability, the requirements for dispersion, duplication of critical facilities, and passive defense measures, such as protective shelters, camouflage, and dummy installations, must be carefully considered. Vulnerability of the base to conventional attacks or to attacks by guerrilla forces may generate additional construction requirements. Camouflage requirements will be related directly to the capability of enemy airpower and ground surveillance. Command and communications centers, ammunition and petroleum storage facilities, and aircraft parking areas may require special protection. Tactical forces may be required to secure the base area, and special precautions may be necessary for the identification and processing of local labor.

k. The period during which a base will be occupied bears heavily on the standards to which it will be constructed. If it is to be used merely in the line of advance, the base should be of austere construction and its rollup (i.e., withdrawing of forces) should be expressly planned. When long-term or future peacetime use of a base is anticipated, higher standards of construction are appropriate to reduce subsequent operational and maintenance costs.

l. Chapter 2, FM 101-10-2 describes the types, characteristics, and capabilities of engineer units for force development.

8-30. Army Facilities Components System (AFCS)

a. The AFCS is a military engineering construction support system for commanders and military planners to use in selecting facilities and installations to be used in military theaters of operations. It consists of a series of DA technical manuals (TMs 5-301-1, 5-301-2, 5-312 and 5-303) which contain planning guidance, designs, bills of materials, logistics data, and an automated data base that describes preengineered facilities, buildings, other structures, and works commonly required by military forces for base development, lines of communications activities, and tactical operations. The system may also be used to support CONUS mobilization construction and, selectively, for disaster relief and peacetime temporary construction. The AFCS provides planning, construction, and logistics data for:

- (1) Preparation, support, and execution of BDPs.
- (2) Preparation of materiel requirements to support BDPs and operational projects.
- (3) Estimation of material, costs, manpower, and tonnages required for military engineering support of military operations.
- (4) Guidance to construction organizations as to site layouts, construction and erection details, bills of materials, construction effort, and equipment.

(5) Climatic options in facility designs suitable for use in temperate, tropical, desert, and frigid environments.

(6) Options in facilities designs for tailoring them to:

(*a*) Various degrees of operational responsiveness.

(*b*) Construction standards and methods suitable for either phased development or for the improvement of operational facilities.

(*c*) Initial construction standards adaptable to what construction materiel, manpower, and equipment are available.

(7) Expediting requisitioning procedures.

(8) Stockage and shipping.

b. The AFCS maintains catalogs of installations and facilities that can be selected to satisfy both the construction requirements of a military function, organization, or activity in various environments (a(5) above) and the standards of construction specified by the unified or component commander. The AFCS includes designs and construction details for built-in-place facilities as well as alternative designs and erection details for preengineered, prefabricated, prepackaged, and relocatable facilities. Publications pertaining to the system provide facility characteristics, construction drawings, materiel listings, and related logistics planning data. Construction and logistics data in the system are cataloged to permit full employment of automatic data processing (ADP) procedures.

Section VII. PERSONNEL SERVICE SUPPORT

8-31. Personnel Service Support Planning

a. Personnel Service Support (PSS) consists of the following functions: personnel service, administrative services, health service support, finance/comptroller support, postal services, chaplain activities, legal service support, morale/welfare support activities, public affairs and general purpose automatic data processing (ADP) support. These functions serve to not only maintain the command in sufficient numbers and MOSs to accomplish the mission, but also to maintain morale and the general welfare.

b. Planning requirements will vary depending upon the level of conflict (low, mid, high intensity) and whether or not a US presence has been previously established. In an established theater, the

responsibility for performance of PSS functions will be well defined. These functions may be performed through organic capability, commercial contract, host nation or by another service. Planning should cover any required expansion of these functions to support augmentation forces being deployed to the theater. Planning should also identify those functions being performed by other than organic resources as new arrangements may be required. In a new operational area, PSS functions must be performed by the deploying force. Priority must be given to the combat critical functions; however, sustainment functions (especially chaplain activities and postal services) must be established as soon as possible in order to maintain morale. Mobility requirements will preclude the establishment of "permanent" locales dedicated to the performance of a given function.

Section VIII. SUMMARY

8-32. Summary

a. The planning for combat service in support of an Army component commander's OPLAN is a complex, time-consuming process. It is based on logistics principles enumerated in FM 700-80 and concepts and doctrine as stated in FM 100-10 and other functional services documents. It requires that planners have knowledge of the principles and doctrine of logistics as well as the Army logistics system in general. The Army-in-the-field support command commander should have some idea of how he will be supported by the wholesale system. Planners also should have knowledge of governing regulations and directives, pertinent supply bulletins, and technical manuals.

b. Some other general considerations for planning CSS are:

(1) *Logistics.*

(a) Maximum use of local resources.

(b) Maintenance of only essential stockage levels in the theater.

(c) Reduction of OST by heavy reliance on airlift for resupply of selected class IX and class II items.

(d) Maximum use of DSS and throughput.

(e) Maximum utilization of containerized shipments and less break bulk operations.

(2) *Personnel and Administration.*

(a) Maintenance of only emergency data and minimum records in the AO.

(b) Centralized finance and comptrollership operations in CONUS.

(c) Establishment of short evacuation policy.

(3) *Civil Affairs.*

(a) Minimizing civil affairs activities.

(b) Predominately employing command support civil affairs units.

c. Command and Control and Management Information Systems.

(1) The ability of the corps CSS elements to move rapidly from peacetime to wartime operations is dependent upon the flexibility of the ADP support systems to make the transition. Logistics planners are responsible for insuring the systems which support the CSS functional areas are planned to make this rapid transition. Some of the basic considerations involved in this planning are:

(a) Determining wartime requirements.

(b) Assessing current system(s) capabilities.

(c) Modifying current systems to meet wartime requirements.

(d) Designating systems and designing system modules which can be deleted for wartime transition.

(e) Operating systems in peacetime on the same equipment required for wartime processing or identifying wartime requirement and workload requirements.

(2) Command and control of CSS functions will depend to a large degree upon the information provided by the automated systems. These data must feed both the CSS decision process as well as the corps command and control requirements.

(3) Planning should include provisions for continuity of operations to include manual backup procedures. This can only be achieved by minimizing ADP requirements for CSS operations in theater and structuring ADP support for the CSS company unit organizations. Total reliance upon automated support for CSS functional systems cannot be accepted for wartime requirements. Manual backup must be planned.

(4) To the degree that automation supports CSS, it must be a major factor in planning for these functions. This planning must be an integral part of each step of force development and force deployment.

CHAPTER 9

HEALTH SERVICE SUPPORT PLANNING

Section I. INTRODUCTION

9-1. General

a. The objective of military medicine, to conserve fighting strength, dictates that patients be examined, treated, and returned to duty as far forward (as early in the phased health service support system) as possible and that health service support resources be employed to provide the utmost benefit to maximum personnel in support of the mission. When a wide disparity develops between the patient workload and the treatment capability, it may become necessary to concentrate that capability upon those patients who can be returned to duty immediately and those for whom resuscitation can be accomplished with a minimum expenditure of personnel, supplies, and time. Planning for health service support is a dynamic process. Detailed planning principles are discussed in FM 101-5, FM 101-10-1, and FM 8-55.

b. The health service support system is a single, integrated system that reaches from the forward areas of the combat zone (CZ) in the theater of operations to the Continental United States (CONUS). This system entails the effective medical regulation of sick, injured, and wounded soldiers in the shortest possible time to the treatment facilities capable of providing the required treatment. The sick, injured, and wounded are regulated and evacuated without regard to lateral or rear boundaries.

c. Nonmilitary personnel who accompany combat forces or who function within a theater of operations (e.g., press, contractors, Logistic Assistance Representatives, and Red Cross personnel) are authorized treatment in military medical facilities and evacuation as specified in AR 40-3. Medical assistance to other civilians is provided within the limits of available health service resources. The civil affairs organizations have the basic responsibility for working with and through civilian health agencies, thus providing the normal link between the civil-military operations (CMO) officer, his subordinate units, and the appropriate command surgeon.

d. Although graves registration and return to duty of personnel from medical facilities are very important, they are not health service support functions. The prompt and timely performance of both of these functions by nonmedical units prevents possible adverse impact on the operational effectiveness of medical treatment facilities.

9-2. Principles of Field Medical Support

a. Continuity. The principle of continuity is to provide optimum care and treatment to the sick, injured, and wounded in an uninterrupted manner. Continuity in care and treatment is achieved by moving the patient through a progressive, phased health service support system, extending from the forward area of the CZ to the area as far rearward as the patient's condition requires, possibly to CONUS. Each type of health service support unit contributes a measured, logical increment appropriate to its location and capabilities.

b. Control. The principle of control is to insure that all health service support resources are deployed accurately and on time, and that the scope and quality of medical treatment and care meet the professional standards and policies of the Army Medical Department (AMEDD). Capability to provide professional care and treatment at various levels in the system is achieved through uninterrupted control by medical personnel in the deployment of medical units, personnel, facilities, equipment, supplies, and evacuation means at the right places and times for accomplishment of health service support plans. Reliable, timely, and accurate communications are also essential and indispensable to health service support in order that patient-related data can be received promptly at medical command and control elements, so that evacuation means can be dispatched for patient pickup and directed to deliver the patient to the most appropriate destination. Communications means must be adequate and available to each medical organization. The health service support system includes the operations of a medical communication subsystem. Medical communications

serve a time-sensitive product—the patient; therefore, speed and simplicity are demanded and the communications procedure cannot be delayed by competing priorities.

c. Proximity. The principle of proximity is to keep morbidity and mortality to the minimum by prompt acquisition of the casualty into the health service support system. Health service support resources are employed as close to the area of combat operations as the time/distance factors and the tactical situation permit. Patients are either transported to the medical treatment facility, or the treatment facility is moved to the patients.

d. Flexibility. The principle of flexibility is to be prepared to shift health service support resources to meet changing requirements. Changes in tactical plans or operations make flexibility in health service support essential. Since all health service support units are used somewhere within the theater and none held in reserve, the medical commander

makes alternate plans for redistribution of health service support resources as required.

e. Mobility. The principle of mobility is to maintain close health service support of maneuvering combat forces. Medical units must have mobility equal to or greater than the units they are supporting. The mobility principle is applied to the health service support system as a whole. For example, if one unit is immobilized, a similar unit may be leap-frogged past it. An immobilized unit may be given priority in evacuating its patients as they become stabilized, and its resources may be moved by echelon.

f. Conformity. The principle of conformity is to provide health service support to the sick, injured, and wounded soldiers at the right time and place. In application of the principle of conformity, the health service support planner analyzes the commander's tactical plan of operations to determine the health service support requirements, and plans the required support to conform to tactical operations.

Section II. UNIFIED COMMAND MEDICAL PLANNING

9-3. Health Service Support in Unified Commands

a. The commander of a unified command has the authority to coordinate logistics and administrative support of component forces, including health service support of the unified command (Joint Chiefs of Staff (JCS) Pubs. 2 and 3). This is in addition to his vested authority as a commander, including his strategic and operational responsibilities.

b. A unified command surgeon is designated for each unified command. Liaison is established between the unified command surgeon and each component command surgeon. The duties of the unified command surgeon are normally advisory, planning, and supervisory as they pertain to the overall health service support of the command. His normal responsibilities include;

(1) Insuring that hospitalization and evacuation facilities provided by the components meet health service support requirements of the unified commands and that there is no unnecessary duplication of facilities.

(2) Assisting in the formulation of the theater evacuation policy.

(3) Coordinating and supervising the activities of the Joint Medical Regulating Office (JMRO) when established. The JMRO is primarily responsible for the evacuation of casualties out of the

theater of operations through coordination with the US Air Force (USAF).

(4) Coordinating component services' preventive medicine activities.

(5) Coordinating provisions for medical assistance to civilians.

(6) Preparing patient estimates and the medical portions of support annexes to unified command plans.

(7) Coordinating joint utilization of medical areas/facilities and all cross-service medical arrangements.

(8) Coordinating and supervising the activities of the Joint Blood Program Office (JBPO) when established.

(9) Establishing medical training policies for joint operations.

(10) Planning and coordinating the medical portion of joint exercises.

(11) Monitoring medical supply and medical equipment maintenance procedures of the component commands.

c. Each military department operates its portion of the overall hospitalization system in a unified command and each determines its requirements in accordance with service policy. Hospitals in the unified command may be jointly staffed and used or they may be staffed by one service and used by all. Medical care of military patients of unified

commands in civilian and allied military facilities is restricted to emergencies. Enemy prisoners of war (EPW) receive medical care in accordance with the provisions of the Geneva Convention of 12 August 1949. Medical care of civilian casualties in occupied areas is also provided in accordance with the provisions of the Geneva Convention. The general doctrinal organizations and practices of the medical components of the Army, Navy, and Air Force are outlined in FM 8-8.

d. Each of the component services is responsible for providing or arranging for the provision of the logistical means required to accomplish the medical mission, to include all hospitalization and evacuation support in an area occupied or used exclusively by that component. Each component maintains command blood programs which are coordinated by the JBPO. Responsibility for technical control over medical activities necessary for proper patient care, records, disease prevention, training, budgeting; and determination of requirements for and the supply and maintenance of medical materiel is exercised by component commanders through their surgeons.

(1) Joint use may be made of dental facilities and services.

(2) The US Army is designated as the DOD Executive Agent for providing military veterinary services worldwide throughout the armed services and DOD agencies. These veterinary services include the wholesomeness (including the presence or absence of NBC contaminants) and quality assurance inspection of food (except on US Air Force bases), laboratory examination of food products, preparation of directories of sanitarily approved sources for subsistence, procurement, sanitary inspections of establishments supplying food to DOD components, complete medical surgical care of government-owned animals, and prevention and control of animal diseases communicable to man (zoonosis control).

(3) The US Air Force operates Theater Blood Transshipment Centers (BTC) which are strategically located to receive all blood arriving from CONUS. The BTCs store blood for the Quad-Services. Each component arranges for pickup of their share of the blood from the BTC IAW the respective JBPO OPLANS.

e. In joint operations, each component command is primarily responsible for all hospitalization and evacuation personnel and facilities required for its own support; medical supply and maintenance support for its medical equipment; medical units for the interim care and treatment of its patients and those of other services as required; care, treatment, and hospitalization of EPWs and designated

civilians in areas of assigned responsibility; and operation and support of joint use of facilities when assigned.

(1) All medical evacuation by land, including inland water transportation within assigned geographical areas, is the responsibility of the Army component. Aeromedical evacuation within the Army CZ (except in areas supported by Air Force airlanded logistics support) is the responsibility of the Army component for short distances and USAF for longer distances.

(2) The Navy/Marine Corps component command is responsible for sea transportation for evacuation of patients from oversea areas to CONUS; providing offshore hospitalization for joint use as directed by the unified commander; and aeromedical evacuation within the Navy/Marine Corps component command area of responsibility.

(3) The Air Force operates an intratheater and intertheater aeromedical evacuation control center, which consists of aeromedical staging, aeromedical evacuation inflight, medical crews, and liaison teams to support aeromedical evacuation from the CZ and within and between the communications zone (COMMZ) and CONUS.

9-4. Joint Health Service Support Planning

a. The tactical mission assigned to the combat forces is the basic consideration of all health service support planning. Medical preparation and planning is specifically designed to support the tactical operations. Among the most important factors used for sound health service support:

(1) A health service support estimate of the situation.

(2) Coordination of health service support planning peculiar to the medical service of each component; with elements within each service; plans involving joint action among the services; and those involving planning with allied forces.

b. The health service support estimate of the situation follows the process prescribed in the Joint Operations Planning System (JOPS) where it is called medical estimate. The estimate is an examination of all factors which will influence the accomplishment of the mission. The object is to arrive at a sound decision for the proper course of action to be adopted. The fundamental steps include:

(1) Consideration of the command mission.

(2) Consideration of the medical situation and all factors affecting health service, analysis of the

workload, requirements and means available, and development of medical courses of action.

(3) Evaluation of various courses of action, including outstanding features, controlling limiting features, and comparative advantages and disadvantages.

(4) Assessment of the enemy's potential for inflicting physical damage including the use of nuclear, chemical, and biological weapons and his ability to impede or prohibit evacuation of friendly personnel. Enemy health conditions may affect the health of our own forces and are indicative of requirements for the care of EPWs and civilian detainees.

(5) Evaluation of friendly capabilities including strength, combat effectiveness, position, weapons, and plan of action. These are weighed against the enemy capabilities to project casualty data used to determine estimated workload.

(6) Consideration of the environment in which the operation is to take place, which can impact greatly upon the requirements and capabilities of medical service units. The availability and condition of road nets, landing strips, railroads, harbors, and other geographic features directly influence the ability to evacuate patients and influence construction of facilities. The climate can cause frostbite, sunburn, trenchfoot, heat prostration, or other ailments. It can also interfere with land and air evacuation as well as contribute to the deterioration of medicines, drugs, and medical equipment. Information concerning the types of diseases, sources, frequency, severity, and current results of preventive measures are needed to plan disease control measures. Other potential sources of diseases are insects, animals, vegetation, and the sanitary aspects of the preparing, handling, and serving of food and similar information about water supplies.

(7) Making a preliminary estimate, including the probable number of patients, the types of patients, their distribution in time and the areas of greatest patient density from the information in preceding paragraphs. The computation of hospital bed requirements; the number and types of medical units needed; additional transportation needed to evacuate patients, move medical units, or supplies; and the amount and kinds of medical materiel requirements are calculated from the estimated patient load. Included also are requirements for medical disposition, intelligence, environmental health, dental, veterinary, and EPW support. These computed requirements are evaluated in relation to organic capabilities of major combat forces, medical units that have been made available, supplies on hand, and the capability for replenishment.

(8) Recommending medical support. After determining the courses of action open to him, the probable effect of the enemy capability on the success of each course of action, and weighing the advantages and disadvantages of each, the health service support planner (staff surgeon) determines that course of action which will contribute the most to accomplishment of the mission and recommends to the support commander what medical support should be provided and the employment of medical units.

c. Evacuation policy:

(1) The theater patient evacuation policy is established by the Secretary of Defense with the advice of the JCS and upon the recommendation of the theater commander. The period of time stated in the theater evacuation policy will commence for the patient on the date of initial admission to any hospital within the theater of operations. The total time spent in all hospitals, both in the CZ and/or the COMMZ, for treatment of a single episode of illness or injury should not exceed the number of allowable days of noneffectiveness stated in the theater evacuation policy. Patients who, in the opinion of a responsible medical officer, cannot be returned to duty within the period prescribed, are evacuated on the first available transportation if the patient's medical condition permits.

(2) Subordinate commands may establish intratheater patient evacuation policies within the limits of the theater patient evacuation policy and subject to approval by the theater commander. For example, a short evacuation policy usually is established for CZ hospitals so as not to impair their mobility or their capability to accommodate surges of patients. Intratheater patient evacuation policies must be flexible and changed as dictated by the tactical situation. Intratheater evacuation policies may differ among the hospitals depending on their location, facilities, staffs, and the types of patients received.

(a) *During static situations.* During a slow-moving or stabilized situation, when patients are hospitalized at a fairly constant rate, CZ policies may be changed to permit longer retention of patients who do not require specialized treatment in a COMMZ general hospital.

(b) *During heavy combat.* When heavy combat causes a large number of patients, the intratheater patient evacuation policy must be reduced to make beds available for current and anticipated needs. As a result, fewer patients admitted for treatment are retained. In addition, the displacement of hospitals will temporarily reduce the number of beds

available for patients and requires that more patients be evacuated to the COMMZ.

(3) Evacuation policies are primarily used for patient management and medical resource allocation planning. They will affect numbers of patients returned to duty within the various levels of hospitalization and direct impact on:

(a) The number and type of medical units required in COMMZ to support the CZ.

(b) The amount of medical materiel requirements.

(c) The volume and type of transportation.

(d) The rate of patient returns to duty.

(e) The theater personnel replacement requirements.

(f) The amount and timing of engineering support.

(g) The number of hospital beds in CONUS to support the theater.

(4) The shorter the theater evacuation policy, the fewer the number of hospitals that will be required in the theater and the greater the number of hospital facilities that will be required in CONUS. Since a shortened evacuation policy means a greater flow of patients from theater to CONUS, the personnel replacement and transportation requirements will be increased.

(5) All available forms of transportation must be considered together with the details of patient handling. While it is DOD policy that patients of the Armed Forces will be evacuated by aircraft when air transportation is available and feasible, the planner must also consider surface medical transportation such as field and bus ambulances, trains, and ships. Convalescent patients and those others requiring evacuation outside the area will be transferred to other units leaving the area. The efficiency of medical support operations depends on the effective distribution of patients to those facilities that are capable of providing the required treatment in the shortest possible time.

d. Based on the health service support estimate, the planner must determine what medical practices, procedures, and policies are best adapted to the area of operations or to the operation (see Chapter 2, FM 8-55). Generally, existing standing operating procedures (SOP) can be used, but it may be necessary to devise entirely new procedures. These procedures cover insuring that per-

sonnel involved in the operation are physically fit; preventive medicine requirements; the routing and controlling of evacuation movements and the location of evacuation facilities; professional care requirements and the location and employment of various types of hospitals to include times of opening, closings, movement, changes in personnel and equipment; the amounts and types of medical supplies needed; location of supply installations and maintenance facilities; sources of blood products and substitutes; records control; amounts and types of medical training required; and other procedures as required.

e. Based on the health service support estimate, the medical procedures, and the resources allocated, the health service support planner determines the number and types of units available, and allocates responsibilities to each major unit. Along with the determination of units required, the planner must also provide for adequate replacement of personnel, especially those possessing critical skills. He must also plan for providing the right skills at the right place and time, based on changes in the tactical concept of operations.

f. The health service support estimate is used by the base development planner and the logistics planner to determine the construction effort required to provide hospitals and other facilities for medical care of the forces. In a large landmass theater of operations, the number of hospitals required to provide fixed-bed requirements may be considerable. The capabilities of the engineers to construct hospital plants may well influence evacuation policy by phase.

g. Another major factor for consideration in planning the hospitalization program for a theater of operations is that of phasing the hospitals into the theater. This requires long-range planning. Hospital units must be organized and trained and be ready for shipment at the time required. This requires full coordination between the theater of operations commander and the zone of interior commander who must provide the hospitals. The time element is dependent upon the accumulation of patients, which in itself is dependent upon the phased buildup of theater strength, a determination of the strengths to be supported, and a planned increase of the evacuation policy. As the theater buildup is accomplished, the evacuation policy normally will be increased until the optimum policy is reached.

Section III. SERVICES WITHIN THE HEALTH SERVICE SUPPORT SYSTEM

9-5. Dental Services

a. Dental Support. Dental personnel are located throughout the theater to provide dental care and thereby prevent unnecessary evacuation of individuals who require either emergency or definitive dental treatment. The control and technical supervision of these personnel are accomplished by Dental Corps officers in command or staff positions.

b. Unit Dental Support. Unit dental support is twofold. It provides emergency treatment necessary to return dental patients to duty as quickly as possible or to prepare them for further evacuation. It also institutes as many preventive measures as possible to reduce the dental patient load. This support is provided by dental personnel organic to divisions, separate brigades, and Special Forces organizations.

c. Hospital Dental Support. Hospital dental support is provided by dental personnel organic to each hospital and convalescent center. These personnel may provide definitive treatment capability for inpatients, staff members, and patients referred from area dental detachments.

d. Area Dental Support. Area dental support, provided in the CZ and COMMZ by dental personnel listed in the Table of Organization and Equipment (TOE) 8-670, Dental Service Detachments, provides definitive dental treatment to all personnel in a given geographical location. The level of treatment is contingent upon resources, time, types of procedures, and number of personnel to be treated. Priority of treatment in rear areas is given to personnel in divisions or brigades retraining, regrouping, or in reserve. Command of area dental support units usually remains with the dental headquarters to which the units are assigned.

e. Dental Staff Officers. Dental staff officers are assigned by TOE to medical commands (MEDCOM) and medical brigades and are included on the staff of the theater Army surgeon.

9-6. Veterinary Services

Veterinary services are an integral part of health service support within a theater of operations. They include assuring food wholesomeness, food hygiene, safety, and quality assurance inspections; sanitary inspection of food processing, storage, and distribution facilities; control of animal borne and foodborne diseases; assistance in the preventive medicine program; complete medical and surgical care of military-owned animals; and preventive

medical aspects of civic action programs. They also entail inspecting, monitoring, and testing subsistence and food producing animals contaminated or suspected of being contaminated with nuclear, biological, and chemical agents. When directed, they participate in other activities. For veterinary services to be effective:

a. The organization, doctrine, training, and equipment must be adequate to support the entire theater under all conditions and in any environment.

b. The services, either routine or emergency, must be available as far forward as operational requirements and the tactical situation permit.

c. The veterinary units must respond quickly to rapidly changing tactical situations.

d. The veterinary personnel must emphasize the preventive aspects of their duties, such as reducing the deterioration and spoilage of subsistence and the incidence of both animal borne diseases, and disease and injury in military animals.

e. Area veterinary services are provided by veterinary detachments and items (TOE 9-680) allocated to support geographical areas in both the CZ and the COMMZ.

f. Veterinary staff officers are assigned to the staff of the surgeon of the theater Army MEDCOM and of the major medical brigade headquarters supporting the corps.

9-7. Preventive Medicine Services

a. Preventive medicine services enhance unit effectiveness by reducing individual soldier's exposure to disease and other environmental hazards. These services normally are provided at all levels of health service support in the CZ and in the COMMZ. They are dependent upon the development of command interest and support. Preventive medicine services entail:

(1) Assistance in the control of arthropod and rodent vectored diseases, including technical consultation, entomological surveillance, and reinforcement of the tactical unit's organic pest management capabilities.

(2) Assistance in the control of waterborne diseases including water quality surveillance of water purification and storage facilities and technical consultation in the treatment of water under all field conditions.

(3) Assistance in the control of foodborne diseases, including surveillance of ice and dining facilities.

(4) Professional supervision of immunization and drug prophylaxis activities for the prevention or suppression of communicable diseases.

(5) Assistance in the control of excessive occupational exposures to such hazards as ionizing and nonionizing radiation, toxic gases, noise, and climatic extremes.

(6) Assistance in the identification and investigation of disease outbreaks and advice on appropriate preventive and corrective measures.

(7) Technical advice on medical aspects of nuclear operations.

(8) Education of troops in appropriate hygienic practices and the training of field sanitation teams.

(9) Technical consultation concerning the selection and development of bivouac sites, cantonment areas, refugee camps, and EPW compounds.

(10) Technical consultations in the renovation or repair of public utilities of towns and villages located in the area of operations.

(11) Professional and technical advice to commanders at all levels on measures to reduce non-effectiveness from disease and injury.

(12) Surveillance of military environments in general to detect and identify actual or potential health hazards and to formulate suitable means for minimizing their effects.

b. Unit preventive medicine countermeasures and field sanitation team services are the responsibility of the unit commander (AR 40-5). Area services are provided by preventive medicine detachments organized under TOE 8-620 and provide services that are beyond the capability of unit personnel due to their complexity, scope, or specialized nature. Special environmental conditions may be the overriding considerations in tactical health service support planning and may have immediate impact on the number, composition, and target dates for arrival of preventive medicine teams/detachments and supplies needed to implement control measures.

c. The theater Army surgeon's section and the MEDCOM headquarters include a preventive medicine staff officer. In addition to serving as a technical advisor, the preventive medicine officer also may assist the surgeon in staff supervision of the activities of assigned and attached preventive medicine detachments. Other assigned preventive medicine personnel normally include medical entomologists, sanitary engineers, environmental science officers, nuclear medical science officers, and preventive medicine specialists.

d. Equipment retrograde is a program designed to reuse and/or rebuild salvageable equipment and

materiel from the theater of operations which results in substantial supply economy of critical and high-demand items. The US Department of Agriculture (USDA) and the US Public Health Service (USPHS) are required to inspect all international cargo consisting of such equipment which enters CONUS. A military program is established in the CZ and the COMMZ to provide this inspection for equipment cargo loading points. This is accomplished in conjunction with representatives of the USDA and USPHS. Inspectors are normally preventive medicine specialists who are trained and certified as military quarantine inspectors and are normally provided from available preventive medicine assets.

9-8. Medical Laboratory Services

Within the theater of operations, medical (clinical) laboratory services are provided in all hospitals, convalescent centers, dispensaries, division medical companies, and separate medical treatment companies. The capabilities within these units vary from only one medical laboratory specialist in a dispensary to a pathologist and Medical Service Corps (MS) clinical laboratory officers in a large, sophisticated clinical laboratory in a general hospital. Laboratory requirements which are beyond the capability of a unit laboratory are forwarded to the next larger medical treatment facility or to designated separate laboratories, specialized laboratories and, on occasion, contract laboratories. Included in laboratory services are all of those tests with their related activities that identify and evaluate risks to human health. Most of the specialized laboratory testing is accomplished by medical laboratory detachments organized under TOE 8-650.

9-9. Blood Bank Services

a. Blood bank services are provided in the theater of operations to support US military and, as directed, allied military and indigenous civilian medical establishments. These services are theaterwide and coordinated with the Joint Blood Program Office (JBPO) which interfaces with the DOD Military Blood Program Office (MBPO) in CONUS. Blood bank services encompass the provision of volunteer blood donors by all commands in accordance with their respective command blood programs. Included in the functions of the blood bank services are the following: providing medical technical services to evaluate prospective donors and collect blood from suitable donors; testing and classifying the blood for transfusion; providing protective conditions during transport and storage; providing pretransfusion testing to insure suitability

ity for the specific patient; and preparing and/or maintaining data and reports for assessing and managing the services provided. Some blood is provided from within theater resources, however, the majority of blood requirements will be provided from CONUS.

b. Each service within the theater is expected to maintain a capability for self-support of its own forces. In joint operations, the JBPO is established on a full-time basis under the supervision of the joint surgeons. (See FM 8-8 for details of the functions of the MBPO in joint operations.) The theater Army blood program officer normally serves as the Army representative in this agency and functions as its chairman when the Army has the preponderance of forces in the theater. Specialized US Army Blood Bank units and blood bank units/personnel from other services provide for control, collection, processing, storage, and distribution of blood products in support of the theater blood requirements. All theater blood activities are managed and coordinated by the JBPO.

c. Blood processing detachments (team NA, TOE 8-620) normally are attached to the blood bank service headquarters (AJ TOE 8-620) on the basis of one per three blood collecting detachments (team NB, TOE 8-620). These detachments receive, process, and store blood collected in the COMMZ. Blood collecting detachments (NB) are attached to the blood bank service headquarters detachment on the basis of one per 80,000 personnel supported. These detachments normally are employed only in the COMMZ and normally collect blood from non-combatants (NEO), combat support and combat service support personnel. NC detachments are assigned to the Blood Bank Service Headquarters Detachment and normally attached to another medical unit for administrative/logistical support. Blood distribution detachments (team NC, TOE 8-620) are allocated on the basis of one per 100,000 personnel supported. NC detachments normally are attached to the blood bank service headquarters detachment and are used for the movement of blood on relatively short trips to and from airfields, to and between the central blood bank and its subcenters, between blood collecting and storage facilities and, on a limited basis, to medical facilities along the route. When conditions such as long distances (excess of 88 kilometers) or travel over rough roads are required or expected, plans must be made to move blood by air, except when the tactical situation, weather, or other conditions prevent air movement. Plans for air movement must be considered when allocating available aircraft resources for mission assignments. Air ambulance units provide emergency transportation for

blood products and blood substitutes, and routine transportation on a backhaul basis. Specific blood distribution systems are developed for the unit by the unified command components and the JBPO.

d. The resources of the theater Army medical laboratory detachments are available to provide technical assistance, as required. A qualified pathologist normally functions as the transfusion consultant to the theater Army surgeon.

9-10. Medical Supply, Maintenance, and Materiel Management

a. The medical commodity (class VIII in the classes of supply structure) consists of the necessary materiel for use in medical, surgical, veterinary, dental, optical laboratory, and allied disciplines.

b. Medical materiel is a highly specialized category of supply used primarily by professionally qualified medical personnel of the Army Medical Department. Medical items generally have no application beyond the care and treatment of patients. The ultimate purpose of the products of a medical supply system is the patient for whom the effort was expended in the first instance. The diagnosis, treatment, and prescription of medication for the patient is solely the responsibility of the attending physician. It is necessary that the medical supply system provides timely and effective response to the doctor-patient requirements. The medical supply system must be adequate to meet the needs of the service, and the system must be capable of rapidly adapting to a large increase in patient load in the event of a national emergency with a minimum decrease in efficiency and no compromise in the doctor-patient relationship. The successful operation of the medical supply system is directly dependent upon its close integration with the total medical effort and its supervision by appropriate command surgeons.

c. Providing medical materiel support (medical supplies and equipment, biomedical equipment maintenance, and optical fabrication) is an integral part of the patient treatment and evacuation system. The medical materiel support units responsible for distribution of the support are under the command and control of the medical brigade at the corps or CZ level and of the medical command at the theater Army or COMMZ level. These units are established in areas of customer concentration and/or in proximity to air, rail, or sea terminals and major road nets. To the maximum extent, patient evacuation transportation should be used for the backhaul of medical materiel.

d. The theater Army surgeon advises the theater Army commander in the development of the medical supply and maintenance system, recommending policies and establishing priorities. He plans and supervises technical inspections of this system, determines theater requirements for medical equipment and supplies, and he exercises staff supervision over the requisition, procurement, storage, maintenance, distribution, and documentation of these supplies and equipment. If the requirement to support other components in a joint service operation arises, this contingency should be coordinated with the component concerned and the support provided on an area basis. Requirements for civilian communities and related administration are developed in cooperation with the Assistant Chief of Staff, Civil Military Operations.

e. The COMMZ MEDSOM battalions are assigned to the Medical Command (MEDCOM), under the command and control of the MEDCOM Commander. They are allocated on the basis of one per Corps supported. Major customers include field, station and general hospitals located in the COMMZ. The COMMZ MEDSOM battalion has the dual mission of providing health services logistics support to medical units located in the COMMZ as well as providing support to the Corps MEDSOM Battalion. The COMMZ MEDSOM Battalion performs the functions of receipt, storage and shipment of Class VIII materiel, biomedical equipment maintenance, medical grade oxygen and water, and single and multivision optical fabrication. Resupply of the COMMZ MEDSOM battalion is normally from CONUS sources through Air Lines of Communications (ALOC).

f. The Corps/Combat Zone MEDSOM battalion is under the command and control of the Corps Medical Brigade/Medical Group. It provides area support to medical and nonmedical units operating within its Corps boundary and is allocated on the basis of one per Corps or equivalent supported element. Major customers of the CZ MEDSOM battalion include divisions, Combat Support Hospitals (CSH), Mobile Army Surgical Hospitals (MASH), and Evacuation (EVAC) hospitals, and an area medical laboratory. The CZ MEDSOM battalion performs the following functions: receipt, storage and issue of medical materiel; biomedical equipment maintenance; single vision optical fabrication services; medical oxygen and medical grade water. Resupply is from the COMMZ MEDSOM battalion or direct throughput shipments from CONUS.

(1) The supply and service division of hospitals located in the Corps area stock approximately 10-15 days of Class VIII supply. The supply and serv-

ice division of hospitals provides medical resupply support activities to their respective hospitals and may be tasked to provide area support for Class VIII supply to medical and nonmedical units. The supply and service division also provides medical equipment maintenance support to hospital activities.

(2) The division medical supply officer (DMSO) of the medical battalion/main support battalion provides medical supply and biomedical equipment maintenance support to the Army division. The DMSO maintains a prescribed load to support sets, kits, and outfits (SKO) contained in the unit and division level treatment facilities. The load may consist of items contained in those unit and division level SKOs and other items that are demand supported. In the absence of demand history, the items/quantities contained in the Medical Instrument and Supply Set, Resupply Set No. 1 may be used as an initial start point. This set is not normally requisitioned or issued as an end item, and if used as a basis for estimation, must be modified based on the unit mission, organic storage and transportation capabilities, and the potential for timely resupply. The DMSO receives replenishment through line item requisitioning and back-up biomedical equipment maintenance support from the supporting CZ MEDSOM Bn.

g. Biomedical equipment maintenance performed in the theater will conform to the three level maintenance concept. Biomedical maintenance performed at the Corps MEDSOM battalion will be Intermediate Forward and will concentrate on repair and return, employ contact teams and maintain limited float of critical items. The COMMZ MEDSOM battalion will provide biomedical maintenance support to the medical units in the COMMZ and backup support to the Corps MEDSOM battalions. The COMMZ MEDSOM battalion will provide Intermediate Forward, Intermediate Rear and Sustainment level medical maintenance and will concentrate on repair and return to stock for the corps and repair and return to supported medical units in the COMMZ. An expanded maintenance float of designated items will be maintained at this level.

9-11. Optical Fabrication

Optical fabrication support will be found throughout the theater. Division level support will be limited to fabrication of semi-finished prescription single-vision lenses and spectacle repair services to all assigned or attached units. Optical fabrication requirements beyond the capability of the Division will be provided by the Corps/COMMZ MEDSOM battalions on an area basis. The Corps MEDSOM

battalion will provide single vision fabrication and spectacle frame repair. COMMZ MEDSOM battalions will provide single and multivision spectacle fabrication and spectacle frame repair to the COMMZ on an area basis and backup to the Corps.

9-12. Medical Food Services

Medical food services are provided at each level of health service support within a theater of operations; TOE hospitals provide the full range of medical food services for patients. These services include preparing and serving regular and modified diets, assessing the nutritional needs of patients, and providing nutrition education to include dietary counseling of patients. The Chief of Medical Food Service is responsible for coordination of patient and staff ration acquisition through the Class I supply system.

9-13. Supplies for a Theater of Operations

a. Medical supplies for a theater of operations are acquired primarily from the Defense Personnel Support Center (DPSC). All requisitions for medical materiel from Army oversea activities are routed through the Defense Automatic Addressing System (DAAS) for establishment of essential controls and the expedition of status information to the requisitioner.

b. Medical supplies to satisfy the initial support requirements of a-

(1) Mature theater come primarily from prepositioned war reserve stocks in the theater. These stocks are intended to fill the void created by the lag in establishing the functional pipeline from CONUS or other sources outside the theater.

(2) Developing (contingency) theater come from the medical units, to include the MEDSOM battalions, preplanned basic load and any existing prepositioned war reserve stockpiles. (To deploy with the necessary class VIII materiel, the planner must possess a detailed understanding of each contingency plan and the type and number of units that his unit may be tasked to support.) The current standard resupply sets are *not* intended to be requested as a single stock number (end item) for resupply but serve only as planning and management tools for the medical logistician to be used to satisfy initial support requirements. When the logistics pipeline is established, line item requisitioning supports the theater.

c. In establishing MEDSOM units, the following should be considered:

(1) The general locations of medical materiel activities are chosen along the proposed axis of advance with consideration given to the tactical

and strategic effort, the location of ports, and the major usable transportation facilities. When selecting specific locations, however, one must consider such factors as adequate dispersion because of the nuclear threat, defensibility of installations, local roads, disposition of troops, rail sidings, adequacy of local communication facilities, existing buildings and structures, utilities, and the availability of local labor. According to the Geneva Convention, medical stocks must be stored and distributed separately from other classes of supply to be considered protected materiel under the provisions of the Geneva Convention.

(2) Medical supply installations should be near railheads, ports, airfields, and highways to minimize hauling. As transportation means are always at a premium, economical and full use of available transportation is essential. Plans are developed for using the most efficient and economical transportation means. To minimize the rehandling and re-shipping of medical supplies, it is desirable that shipments from debarkation ports or beaches be made directly to forward areas whenever possible. Bulk quantities of medical supply items can easily be assembled at the port or beach area, documented, marked, and loaded for shipment to forward supply installations. Shipment of medical supplies should always be made by the best available means. Throughout distribution is used where possible.

(3) Storage facilities for medical supplies should provide 100 percent covered storage whenever possible. Existing buildings should be used to the greatest extent possible to provide adequately covered, refrigerated, secure, and controlled humidity and temperature storage. Requirements for utilities must be considered. Preservation and packing procedures as prescribed in TB MED 1 must be followed.

(4) Medical supply installations must remain flexible to meet changing situations. The threat of nuclear attacks and the rapidly changing military situation make it necessary that alternative medical supply plans, procedures, and operations be formulated. In certain instances, it may be advisable to establish duplicate records, especially when automated procedures are used, to serve as a backup system. Medical supply levels of installation in forward areas should be kept at a minimum to permit relocation of such installations whenever necessary to provide adequate medical support to the mobile supported units.

(5) Overall space requirements are determined from supply control data and from experience factors for handling medical supplies. Detailed space

requirements should be based on specific assignments of support missions, supply levels to be carried, area and troop served, and types of supplies. Medical unit commanders and staff officers should have an appreciation of storage problems, particularly those pertaining to covered storage if they are to establish appropriate policies covering storage of medical supplies. Consideration must be given to large volume, special handling, and documentation.

(6) Maximum utilization of storage space is basic to economical supply operations. Such factors as accessibility of stored medical supplies, and maximum protection from deterioration, fire, weather, theft, rodents, and enemy action must be considered in ascertaining efficient storage procedures.

(7) Efficient methods should be employed to minimize unnecessary shipments, transshipments, and rehandling of medical supplies. So far as possible, shipments of medical supplies should be accomplished in one move and as far forward as possible. Movement of supplies through successive supply installations should be avoided.

(8) Closely allied with the handling of medical supplies is the control of physical inventories. Inventories will be conducted in accordance with ARs 710-2 and 40-61.

(9) Employment of proper medical supply practices requires that continuous care be exercised in the surveillance of all medical supplies, and in particular, of the deterioration type items. Items must be stored and cared for according to cargo classification. Deteriorating and potency type items must receive special consideration in the rotation of stocks.

(10) Medical supply activities will be located in areas where maximum security is provided. Such locations will be incorporated into plans for the CZ and COMMZ.

d. With certain restrictions, specified items and categories of items of medical supply are authorized for procurement locally within the theater.

Procurement of certain medical supplies from non-United States sources in oversea areas is not authorized unless specific prior approval of The Surgeon General is obtained. Consideration in the procurement of medical items from local sources should include manufacturer technical know-how, sterilization techniques, raw material availability, and production capabilities. Because of the nature of most medical items (mainly drugs and surgical instruments), sound judgment must be exercised. The high standards established by the US Government make it difficult to consider the use of manufacturers in many areas of the world as possible sources of drug supplies. Drug standards vary in different countries, and hence, foreign drugs are used only in emergencies. In practice, locally procured materiel is identified and segregated from similar items of US manufacture. Quality control procedures must be followed as prescribed in TB 740-10, AR 40-61, SB 8-75-9, and the Medical Unique Master Data File (MUMDF).

e. Representative samples of medical supplies and equipment captured from the enemy must be forwarded through command channels to medical intelligence personnel for evaluation and exploitation. When materiel cannot be evaluated, medical intelligence specialists can be requested to make onsite evaluation. The capturing units evacuate all the remaining captured supplies and equipment to designated collecting points where they are stored, maintained, and distributed in accordance with policies. Captured medical materiel will not be used for treatment of US personnel without specific approval of the command surgeon and until inspected by competent medical personnel. Since captured medical personnel are familiar with such equipment and supplies, captured materiel is of particular value in the treatment of EPWs and civil affairs requirements. Compliance with SOPs of the command with respect to captured enemy materiel is vital because of both intelligence value and potential value as issuable assets.

CHAPTER 10

PLANNING EMERGENCY SUPPORT FOR ALLIES

10-1. General

a. Because of US participation in coalitions such as North Atlantic Treaty Organization (NATO) and through bilateral agreements, the United States can expect to provide support to allies in any future conflict. This support can vary in range from active participation by US Armed Forces to furnishing definitive logistics support in accordance with negotiated agreements. US forces will operate as part of a combined command alongside allied forces or independently in a joint or specified command configuration. In the former, this could be in an established theater where combined command and control organizations already exist and US forces are already forward such as NATO in Europe and the United Nations Command in Korea. US Army participation could be any size element. Combined commands can also be formed to conduct operations in a theater other than Europe or Korea. In this type environment, US forces are deployed just prior to or subsequent to the initiation of hostilities. A formal command structure is normally not available until just prior to the commitment of forces.

b. US participation may involve only the provision of certain types of combat service support without actual participation by combat forces, similar to the US participation in the Arab-Israeli War of 1973.

c. Ordinarily, the requirements of forces of allied nations are furnished by the parent nation. A US unified command may, as a result of bilateral agreements, provide support to the forces of allied nations. In the latter instance, the requirements for forces of allied nations would be screened by the US unified command to insure that requirements are within the policies set forth in the agreement and that issue would not impair the effectiveness of US Forces. In cases where the forces of the allied nations in question are operating under an allied commander, the requirements would be screened in the light of policies established by the allied commander.

10-2. Combined Operations

a. Allied military forces are combined for the purpose of accomplishing a common objective. In

studying combined forces and the command of them, it is imperative to bear in mind that nations are separate sovereignties and that each has its own enduring aspirations, national goals, objectives, traditions, and trends that act in concert to form the sociological, political, and military differences between them. The sociological differences are evident in the varieties of language, religion, custom, educational standards, and culture represented in the combined forces. Political differences stem from the national objectives of the nations concerned. These differences are normally made compatible with the combined treaties of various types. Such treaties establish the basis for military alliance and coordination and prescribe the nature of military assistance (units, materiel, or both) that the participants shall furnish. Military differences are reflected in the areas of doctrine, standardization of procedures and equipment, command and control techniques, preparation of plans, and expenditure of effort.

b. Sometimes type forces are formed; i.e., combined land force, combined naval force, and combined air force. In such cases, operational command and coordination are accomplished within the command headquarters. Attachments are usually made on a nation-to-nation unit basis. Similarly, logistics support is usually provided on a nation-to-nation basis by the respective national components and monitored at the supreme level only as it pertains to the accomplishment of the operational mission.

c. In NATO, much effort is being expended in the development of a logistics master plan for a NATO logistics system. Also, much has been done in the areas of rationalization, standardization, and interoperability. Another area is the host nation support concept in which the host nation, through agreements with the US commander, accepts the entire responsibility for support of US forces and provides common items from its own resources or US forces may obtain selected host nation assets for use. Where an alliance exists such as in NATO, appropriate agreements and plans are already made and in effect or are being formulated. Where the alliance is formed just prior to or following the outbreak of hostilities, the

necessary agreements and policies of operation must be formulated after the formation of the alliance command structure. Where support of US forces may not be readily achievable through alliance responsibilities and/or host nation support, the United States must provide all necessary support until the capability exists. Joint and combined operations involving corps sized or larger US Army forces are conducted in accordance with the doctrine in FM 100-15, Larger Unit Operations, and FM 100-16, Echelons Above Corps (EAC).

10-3. Logistics Support of Allies

a. Under certain conditions, logistics support is provided to foreign armed forces under the Foreign Assistance Act of 1961, as amended, and the Arms Control Export Act of 1976, as amended, whether or not US forces are employed. When specifically directed or authorized by appropriate authority, Department of the Army materiel, services, and facilities may be furnished to allied foreign governments or international organizations under emergency or combat conditions. In the absence of instructions to the contrary, the support will be furnished on a reimbursable basis in accordance with agreements consummated at departmental or oversea command level. HQDA may, under certain conditions, issue special accounting instructions. A Wartime Standard Support System for Foreign Armed Forces (WSSSFAF) is described in AR 700-7.

b. The unified command OPLAN, as appropriate, will provide for logistics support to foreign armed forces involved in contingency operations. Separate supply schedules are developed by the Army component command for the support of allied forces and US forces employed in the objective area.

c. The US Army may, as prescribed in AR 700-7, furnish through the defense transportation system, items of materiel to US and allied armed forces in selected foreign countries. Allied forces may be provided materiel support authorized by Congress or the President. Materiel support is provided only to selected foreign armed forces to meet authorized emergency or wartime requirements that cannot be satisfied by the nation's internal resources or by expediting delivery of stocks provided through the Military Aid Program (MAP), Foreign Military Sales (FMS), or cooperative logistics supply support arrangements (CLSSA) previously completed and funded. Blanket Open End (BOE) cases are for a level of support. Procurement leadtime is built into supply availability so that fast action cannot be contemplated. These cases are "ordered when accepted" and requisitions define the order for de-

livery one procurement leadtime away. Materiel provided under the WSSSFAF is not part of that provided under the MAP, FMS, CLSSA, or other agreements completed during peacetime. Procurement or supply of materiel under WSSSFAF is financed initially as directed in legislative authority with reimbursements specified in the implementing authorization. Excluded from the WSSSFAF system also are the requisition and issue procedures for Class III (bulk), Class V, and DA publications. These items have their own requisition and issue procedures which will be used. Specifically, DOD Manual 4140.25 and AR 703-1 cover Class III requisitions; AR 700-22 prescribes procedures for Class V; and AR 310-2 covers procedures for DA publications.

d. As a routine course of action, requisitions from allied forces for authorized items are submitted from the allied force logistics center in accordance with MILSTRIP format specified directly to the US Army Security Assistance Center (USASAC). Emergency requirements would go to the theater MMC. These would be handled off line at the MMC for a fill or pass to USASAC. Documentation of all issues to allies is forwarded to the USASAC promptly for necessary financial action.

e. MILSTRAP, MILSTRIP, MILSTAMP, and other military standard systems and related procedures apply to the WSSSFAF.

f. Shipments for a selected country may be diverted by the theater commander to US or other foreign force if required by the local situation based on priority established by DCSOPS, DA.

g. War reserves, project stocks, or other pre-stocked or pre-positioned requirements to support contingency operations for allies are not authorized under WSSSFAF.

h. Within Europe, all bulk petroleum supply for US forces and designated allies is centrally managed by the US Army Petroleum Division of the 200th Theater Army Materiel Management Center (TAMMC) with headquarters in Zweibruecken, Germany. This mission requires the operation of two pipeline systems: Donges Metz Pipeline System (DMPS) and the Central Europe Pipeline System (CEPS).

i. The final facet of the Petroleum Division's mission is to provide an interface with host nations for certain levels of peace and wartime petroleum support. To this end, the maximum readiness of combat systems deployed on the battlefield is attained.

10-4. Allied Mutual Logistics Support

a. Requirements of a Mutual Logistics Support System. The characteristics required to provide mutual logistics support are:

(1) *Responsiveness.* Any logistics system is required to have the capability to operate effectively in any theater of operations. It may be tailored for a particular operational situation, but must have an inherent capability to respond to the fluctuating demands of combat requirements.

(2) *Flexibility.* High materiel usage and loss rates, the nature of operations, and limitations in availability of resources require a logistics system which can rapidly adjust to changes in direction, intensity, and priority. This may be achieved through planning, control, communications, and flexibility in the allocation of resources.

(3) *Mobility.* Logistics mobility must match operational mobility. It is achievable by the effective control and use of all appropriate transport modes, efficient material handling and the avoidance of unnecessary stockpiling of supplies.

(4) *Survivability.* The system must have an inherent capability to provide continuing support under adverse operational or environmental conditions. This can be achieved through passive and active defense, dispersion and prepositioning of assets and provision of adequate margins for losses in materiel and service capabilities.

(5) *Economy.* Logistics resources will be limited in initial supply, through attrition and expenditure, and by replacement requirements. Support must be designed to produce the most effectiveness through conservation, use of local resources and the judicious use of supplies and services in support of essential needs.

(6) *Simplicity.* The delivery of logistics support to field operations involves a number of complex activities, complicated by the threat of interdiction of lines of communication and facilities. Simplicity is an essential ingredient of logistics plans and command and control systems, to allow the flexibility and reaction necessary to continued effective support under demanding and adverse conditions.

(7) *Interoperability/Standardization.* Logistics systems are required to interface in support of allied operations. It is necessary to achieve logistics standardization. Realizing the difficulty, interoperability is the characteristic desired as a minimum.

b. Allied Responsibilities. While allied aims should be directed to achieve optimum standardization and interoperability, Allied armies will develop their basic national logistics systems to support their own particular tactical organizations

and equipments. It is prudent, however, for both efficiency and expediency to plan for mutual support among armies where possible. These areas of planning and execution include:

(1) *Logistics Interfaces.* To establish effective logistics support between armies, it will be necessary to develop the ability to process requirements by establishing:

(a) An understandable vocabulary to enable communication of requirements.

(b) Common cataloging of material to aid in identifying requirements and to indicate acceptability of one nation's resources to other nations.

(c) Points of contact in staff systems to facilitate planning and control.

(d) Points of entry at executive logistics agencies to provide or gain support.

(2) *Decisiveness.* Officers possessing the necessary authority to commit resources under mutual support agreements may be called upon to make decisions which reduce resources available to their own Army. These decisions must be based upon reliable and current information and capable of being rapidly transmitted into action.

c. Logistics Responsibilities. Major mutual responsibilities of partners in a lateral and/or bilateral logistics support agreement(s) are forecasting, financing, organizing, and provisioning of the required resources.

(1) *Forecasting.* Allied armies are required to forecast their needs and the leadtimes associated with the type of materiel will vary considerably between nations. Allied armies' forecasting should be such that orderly routine processes be employed unless unforeseen operational requirements require emergency action. Forecasting of equipment, maintenance, transportation, services, and facilities requirements from other armies must be based on the possible contingencies, area of operation, and the Army's capability to support its deployed forces.

(2) *Financing.* Each nation has a different approach to the financing and accounting for foreign military sales of materiel and nonmateriel resources. Acquisition of materiel and nonmateriel resources from a host nation requires a unique financing and accounting concept. Principles and procedures must be developed for financing and accounting for these resources once obtained by the designated Allied Nation for supplies to other armies. There is a need to establish agreements on financing and accounting for the following:

(a) Routine and emergency logistics resources of the Allied armies provided to each other.

(b) Host nation resources acquired by one Army for the use of other Allied armies.

(c) Resources provided to the host nation or other Allies subject to financial and accounting arrangements.

(3) *Organization.* The aspects of logistics support outlined in paragraph 10-4c(1) imply that the capability exists (or that a requirement exists to establish viable organization) within existing national organizations to facilitate forecasting, planning, coordinating, controlling and executing the functions of logistics; principally the functions of supply, maintenance, movements and transportation, medical evacuation, services, and facilities. Factors which influence these organizational structures are:

(a) Cooperation and coordination among Allied armies must be effectively implemented in peacetime within the combat and communication zones where effective forecasting and demanding of national resources is undertaken.

(b) Authority to provide and/or demand support must be established at the same levels as outlined in subparagraph (a) above.

(c) Responding to the requirements of subparagraphs (a) and (b) above must be through the controlling and exercising of the logistics systems.

(d) The EAC structure must be able to facilitate the above activities.

d. *Aims of Mutual Logistics Support System.* Allied armies aims will be directed to achieve optimum standardization and interoperability. Allied armies will develop their basic national logistics systems to support their own particular tactical organizations and equipments. It will be necessary for both efficiency and expediency to plan for mutual support among Allied armies where it is appropriate. These areas of planning are:

(1) *Control and Coordination of Movements and Transportation.* Limitations on routes, terminals and transportation agencies require tight control of movement priorities and use of transportation facilities, and coordination with civil users.

(2) *Common Item Supply.* Advantages can be achieved in management, inventory, and distribution overheads through the allocation of common item supply responsibilities to one or more armies.

(3) *Maintenance Support.* Economies can be achieved in maintenance, particularly in the communication zone, through the provision of mutual maintenance and recovery support and common

end items of equipment, including closed loop replacement systems for repair and return of common repair parts and components.

(4) *Common Service Utilization.* As for supply, the delivery of services to armies by a single controlling agency can eliminate duplication and reduce distribution penalties.

(5) *Allocation of Facilities.* The control of apportionment of existing facilities and new vertical construction can insure a rational provision of facilities to the force.

(6) *Local Resource Control.* Competition for local resources, both between armies and host nation defense and civil needs, makes it essential that one Army assume responsibility for acquisition and distribution of resources available to all.

(7) *Medical Evacuation.* Planning for medical evacuation must give consideration to both the medical service and transportation requirements of patients and casualties.

e. *Responsibility to Other National Military Services.* Armies have certain responsibilities for the delivery of logistics support to their other services, and receive specified support from them. These liabilities and assets may have a considerable influence on requirements for mutual support and must be covered in planning and in support agreements between armies.

f. *Command and Control.* Achievement of the required logistics support characteristics within the Allied force require that command and control systems be capable of working with each other as a cohesive force. Clearly defined and understood command structures and staff points of entry should be well established between Allied armies and also with any host nation. The development of interfaces through command and staff channels, requisitioning procedures, and communications and data processing interfaces are essential to effect administrative coordination and cooperation.

10-5. DA Responsibilities

At the DA level, the DCSLOG has General Staff responsibility for providing guidance (including program and budget guidance) and policy direction for all logistics aspects of supply support encompassed in WSSSFAF. The DCSOPS is responsible for politico-military aspects of the US Army position on allied forces' participation in WSSSFAF, impact on US Army readiness, and establishing worldwide materiel distribution priorities. The Deputy Chief of Staff for Research, Development, and Acquisition (DCSRDA) is responsible for computing, programing, procuring, and costing materiel requirements with the Army total obligation

authority; assessing the impact on the production base capacity; issuing program authority through the Comptroller of the Army (COA); and insuring that programs are within DA obligation authority and used within limits and priorities established by Congress, Office of Management and Budget and DA program and budget guidance. The Comptroller of the Army is responsible for the financial aspects of the system. Unified commanders, assisted by major oversea Army commanders, establish formal agreements for single pipeline support. The major oversea Army commander with the Commander, AMC, within dollar guidelines, develops

requirements for countries participating, establishes necessary controls on requisitions, and reports materiel furnished for effecting reimbursement. The oversea commander also budgets and provides for administrative support for the operation. Supply support is provided by the Commander, AMC, within the established dollar guidelines in the agreement. The Commander, US Army Training and Doctrine Command develops automated logistics systems for accomplishing reporting requirements and training of foreign armed forces in the use of AR 725-50 and other appropriate supply regulations.

CHAPTER 11

FORCE MOBILIZATION PLANNING RESPONSIBILITIES

11-1. General

a. The Army Force Mobilization Planning Guidance, volume II, to Army Mobilization and Operations Planning System (AMOPS), Deployment Mobilization Troop Basis, or Nondeployment Troop Basis provides guidance for partial, full, or total mobilization. However, the scope of mobilization is dependent upon the military situation and requirements as determined by the Secretary of Defense at the time of the emergency. The AMOPS addresses threats in the short-range period. For the midrange and long-range periods, the Army force guidance document identifies the resources that might reasonably be expected to be made available.

b. Satisfying the force requirements of any contingency is accomplished through mobilization planning. This planning identifies the requirements, assesses the resources available to satisfy the requirements, and makes provisions for satisfying the requirements based on priorities and time-phased requirements of forces, supplies, and equipment for contingency situations. The force requirements of the military situation may require rapid expansion of the Active Army involving the mobilization of Army National Guard (ARNG) and US Army Reserve (USAR) units. The situation may require a partial, full, or total mobilization. The mobilization might be accomplished according to established plans or it might be accomplished without centralized control of Headquarters, Department of the Army (HQDA). The plans of major Army commands (MACOM) should provide appropriate latitude and authority to accomplish the mobilization of Reserve units as necessary, should legally authorized emergency situations exist.

11-2. Mobilization Planning

a. Mobilization plans. Mobilization plans should be developed by all commands, agencies, activities, and installations as required by the MACOM. Major commands may require subordinates to develop a complete, limited, or abbreviated plan, or in certain cases, utilize the plan of the parent or host activity. The coverage of each type plan is prescribed by the higher headquarters. As a minimum, the plans should provide for alerting and mobilizing the forces, administrative processing,

movement of units from assembly areas to mobilization installations, training, logistics support, activation and expansion of facilities, and other actions as required to meet requirements of an expanded Army.

b. Alert plans. Alert plans are prepared by all Reserve component units. These plans include:

- (1) Current roster or card file of unit members.
- (2) Standard and alternate procedures for the receipt and transmittal of alert notification.
- (3) Designation of primary and alternate assembly areas.
- (4) Means of transportation to assembly areas.
- (5) Administration procedures, including:
 - (a) Billeting and subsisting of unit members at assembly area.
 - (b) Updating of supply and maintenance records and requisitions.
 - (c) Medical plan (daily sick call) for the unit.
 - (d) Plans for subsequent movement to mobilization station, including loading plans for vehicles and commercial transportation required to move equipment and vehicles which exceed organic lift capabilities.

c. Movement plans. Movement plans are based on the Reserve component unit commander's assessment of the movement means which normally could be expected to be available in the unit's local area.

(1) Primary emphasis is placed on movement of fully loaded transportation organic to the unit augmented with commercial surface transportation as required. In determining the mode of transportation, unit commanders consider the following:

- (a) Movement is administrative, directly from the home station to the mobilization station.
- (b) Organic transportation is used when the mobilization station is within 1 days' distance by road march.

(c) Personnel in excess of organic transport capacity move by commercial air or surface transportation. Excess equipment and vehicles move by rail or motor transport.

(d) Requirements include the movement of equipment at locations other than at home station.

(2) The movement plan is prepared in accordance with the provisions of FM 55-65 and US Army Forces Command (FORSCOM) Reg 55-1.

(3) Supporting installations provide guidance and assistance, as required, in the preparation of movement plans and related data.

(4) State adjutants general and Army Reserve Commands (ARCOM)/General Officer Commands (GOCOM) provide guidance and assistance to ARNG and USAR units in preparing movement plans and related data.

(5) Supporting installations coordinate passenger and equipment movements with Headquarters, Military Traffic Management Command (HQ, MTMC) or appropriate MTMC area command upon implementation of movement plans.

11-3. Responsibilities

a. Overall General Staff responsibility at the Department of the Army (DA) level for mobilization planning rests with the Deputy Chief of Staff for Operations and Plans (DCSOPS). The responsibilities include establishing priorities for distribution of materiel, and establishing requirements and priorities for the development and acquisition of materiel.

b. The Deputy Chief of Staff for Personnel (DCSPER), DA, is responsible for providing the Commander, US Army Training and Doctrine Command (TRADOC) with information pertaining to the numbers of newly inducted individuals to be trained by military occupational specialty (MOS) for the first 6 months following mobilization. The DCSPER is also responsible for personnel policies for terms of service, length of tours, permanent change of station movements, and use of mobilization designees.

c. The Deputy Chief of Staff for Logistics (DCSLOG), DA, is responsible for logistics readiness of Army forces, managing resources (except major item procurement) required to achieve logistics objectives, and managing all aspects of international logistics support.

d. The Chief, National Guard Bureau, and the Chief, Army Reserve, are responsible for matters which affect the mobilization readiness of ARNG and USAR units.

e. The Chief, US Army Military Personnel Center (MILPERCEN) is responsible for planning and publishing procedures for integrating Reserve personnel into the Active Army. He also maintains records on personnel of units that were mobilized, and requisitions personnel from the Com-

mander, US Army Reserve Personnel Center (ARPERCEN), to fill Active Army unit shortages.

f. The Commander, ARPERCEN, will, upon receipt of requisitions from MILPERCEN and area commanders, fill unit vacancies from existing resources, provide official military personnel files of mobilized USAR officers and enlisted personnel to MILPERCEN to integrate with active duty files.

g. The Commanders, FORSCOM, TRADOC, and US Army Materiel Command (AMC) are responsible for training, guidance, and mobilization readiness for units and installations under their command and logistics support of mobilized units.

h. The Commander, FORSCOM, provides a standard format mobilization plan to subordinate headquarters. Upon receipt of validated requirements, recommends Reserve component units to be mobilized, and upon approval by HQDA, orders units (through area commanders) to active duty.

i. The Commander, TRADOC, prepares a Post Mobilization Individual Training and Support Plan, expands the training base, and restructures Army service schools, as required, to provide trained replacements and technically qualified personnel in needed skills.

j. The Commander, AMC, is responsible for logistical (except medical), administrative, and training support. AMC develops and maintains equipment and supply distribution plans to support the mobilization.

k. The US Army Health Services Command (HSC), through publication of the Army Medical Department (AMEDD) HSC Base Mobilization Plan(s), provides for mobilization of HSC resources to support the Army.

l. The Commander, MTMC, plans for the efficient use and controls of military-owned and commercial Continental United States (CONUS) land transportation resources and capabilities and for the mobilization of MTMC resources, including Reserve units to support operations during mobilization. The Commander, MTMC, also provides traffic management and common-user and commercial ocean terminal support.

m. The Commander, US Army Information Systems Command (USAISC) is charged with providing installation communications and air traffic control support to meet mobilization requirements.

n. The Commander, US Army Troop Support Agency (TSA), plans for the efficient use and control of Army resale commissaries. HQDA will provide guidance on command, control and turnover of commissary resale stocks based on the tactical situation.

o. The area commanders play key roles in the mobilization process. They are commanders of mobilized units as well as the link between the unit and the mobilization station and the major commands. Area commanders are responsible for planning and coordination of ordering Reserve units within their commands to active duty. They actively supervise and control mobilized or assembled units in their commands. They provide necessary information for the Army Personnel Accounting System, and monitor and coordinate submission of the mobilized unit equipment status report to the mobilization station commander. The area commander must provide for the responsibility for US property left at home station and the designation of a custodian for the security and maintenance of each USAR center upon departure of assigned units. Technical assistance is provided to units experiencing problems in personnel, administration, transportation, supply, maintenance, other logistics services, and training.

p. State adjutants general are responsible for keeping area CONUS Army commanders and other area commanders informed of all matters which significantly affect the mobilization of ARNG units under their control. They are also responsible for providing area commanders with mobilization plans for units under their control and providing appropriate mobilization station commanders up-to-date equipment status and serviceability information.

q. ARCOM and GOCOM are responsible in peacetime for the adequacy of units under their control.

r. Installation commanders. Mobilization station commanders are responsible for the preparation, coordination, and execution of a mobilization plan which outlines support to be provided to mobilized units reporting to their installations. They develop plans for emergency expansion of facilities in accordance with the provisions of AR 210-23. Before mobilization, coordination is established with each unit scheduled to mobilize at that station to outline proposed billeting space, support facilities, support provided installation procedures, operating instructions, and unit responsibilities.

s. Unit commanders.

(1) The unit commander's mobilization responsibilities begin when he assumes command of his organization. If none exists, a mobilization plan should be developed in accordance with plans of higher headquarters and periodically tested. Liaison should be established with the mobilization and supporting installation to exchange information on support required, what can be expected and operational procedures to be followed.

(2) Upon receipt of alert notification, the unit commander must notify unit personnel of the alert and advise them regarding when and where to report for duty, processing requirements, individual obligations, clothing, and equipment requirements, and other appropriate instructions. He must also appoint a class A agent officer and an ordering officer to be effective when the unit enters on active duty. He also initiates the necessary administrative unit logistics actions.

11-4. Logistics Support of Reserves

a. The dependence on Reserve forces to enable the United States to execute the operations plans (OPLAN) of unified commanders or for the defense of CONUS dictates the need for comprehensive planning for the changeover from logistics support through ARNG and USAR supply systems to the supply system of the Active Army for those Reserve component units ordered to active duty during a mobilization. Property, supply, and facilities procedures for this changeover are outlined in chapter 6, AR 135-300. Upon entry on active duty, the commanding officer of the unit must provide for subsisting and quartering his troops at home station.

b. After receipt by a unit of notification of alert for active duty, unit commanders inspect individual and organizational clothing and equipment and identify equipment shortages on the Tables of Organization and Equipment/Modification Tables of Organization and Equipment/Tables of Distribution and Allowances (TOE/MTOE/TDA) specified in the alert order status reports. A list of repair parts to fill the 15-day prescribed load list is furnished immediately to the mobilization station commander so he can initiate supply actions to fill the shortages. Requests for supplies and equipment to be delivered to the home station of alerted units are limited to those items necessary for administration at home station and to support the movement of the unit to its mobilization station.

c. Each enlisted member should be provided at least one outer service uniform and one fatigue uniform before departing home station for the mobilization station. Units move with all operable and reparable (at intermediate maintenance level) organizational equipment, expendable items, and serviceable individual and/or organizational clothing and equipment on hand, or as prescribed by AR 135-300, DA Standing Operating Procedures for Mobilization and other appropriate orders, Equipment on hand in Reserve component units may be positioned at home station or at annual training equipment pools equipment concentration

sites (ECS). If located in the ECS, the ECS commander, upon notification of alert of a unit, insures that ECS equipment of that unit is in serviceable condition and shipped to the unit's mobilization station to be returned to the owning unit.

d. Equipment for support of Reserve component units is either on hand in the unit, positioned in specifically earmarked stocks at an Army depot, or pre-positioned in Pre-Positioning of Materiel Configured to Unit Sets (POMCUS) stocks overseas. Quantities of equipment authorized are those quantities considered essential for mobilization training or emergency contingency deployment. Actual availability of equipment determined by priorities in AR 11-12, and current and projected distribution, are reflected in the Total Army Equipment Distribution Plan (TAEDP).

e. After the unit is located at its mobilization station, its logistics support is received from the Active Army logistics system in accordance with established procedures.

11-5. Procedures for Accelerated Mobilization

a. As Active Army forces do not have the proper balance to execute many contingency plans, many strategic Reserve units are required to "round out" the contingency plan force. These must be mobilized quickly for direct deployment and employment to effect implementation of certain plans. These units are selected by DCSOPS, DA, in coordination with the National Guard Bureau, Office of the Chief of Army Reserves, and HQ, FORSCOM. When alerted and ordered to active duty, these units must be ready to assemble at home stations and move to a port of embarkation or place of employment. Selected units must be trained in mobilization procedures as outlined in chapter 10, AR 135-300 and tested to mobilize, process, and move, as required. The area commanders (for USAR units) and the State adjutants general or State area commanders (for ARNG) are responsible for preparing mobilized units for movement to the port of embarkation or place of employment. The supporting Active Army installation will provide such assistance as needed to insure rapid mobilization. This assistance is accomplished by support teams developed by the support installation. The support teams should include the following, as required:

- (1) Personnel Officer.
- (2) Finance Officer.
- (3) Legal Officer.
- (4) Personnel Technician.
- (5) Personnel Management Supervisor.

- (6) Personnel Management Specialist.
- (7) Unit Supply Specialist.
- (8) Equipment Maintenance Specialist.
- (9) Public Affairs Specialist.
- (10) Transportation Movement Specialist.
- (11) Other personnel as required.

b. The members of the support team and other staff officers of the supporting installation should establish direct liaison with units designated for early deployment and with area commanders and State adjutants general. Of particular importance for continuous observation and checking are administrative procedures, personnel servicing, and logistics readiness of selected roundout units.

11-6. Other Logistics Concepts for Mobilization

a. Depot expansion. It is not contemplated that AMC will activate new Army depots for mobilization.

(1) The current AMC materiel support concept calls for three depots (e.g., Sharpe, New Cumberland, and Red River) to distribute secondary items under mobilization conditions. Depot commanders must plan for increasing their operations to three shifts per day, 7 days per week, as required. The Assistant Deputy for Materiel Readiness, HQ, AMC will only activate existing inactive depots or activate new depots if additional capability is required.

(2) Depot maintenance upon mobilization is currently planned to be accomplished in existing facilities. Depot expansion plans provide for increased personnel to include recruitment and training, increased funds, multishift operations, and contract maintenance to satisfy depot overhaul/rebuild requirements.

b. Transportation.

(1) Transportation support for partial or full mobilization requires detailed planning at all levels to provide effective support to time-phased deployment of operational forces, to include movement of personnel and accompanying supplies from home station to mobilization station; movement of deploying units and accompanying supplies from duty station to staging areas and then to ports of embarkation; movement of pre-positioned supplies and resupply items to outloading facilities; the shipment of supplies to allies; and other movement requirements resulting from the mobilization.

(2) The Commander, MTMC, provides CONUS transportation schedules to DCSLOG, DA, in support of mobilization to include mode, home station

loading capability, movement time, and capabilities of mobilization stations, and ports of embarkation to receive and unload/outload. These schedules constitute the Army Transportation Plan, which serves as the Army input to the Joint Transportation Plan. Designated Army, Navy, Air Force, Marine Corps, and Defense Logistics Agency (DLA) installations in CONUS having significant peacetime and mobilization material movement requirements for deployment, supply, or resupply provide data to MTMC on their capabilities to outload and receive materiel under normal and mobilization conditions using onpost transportation facilities (see AR 55-4). These data are used by MTMC for strategic mobility planning. Guidance and assistance on CONUS transportation planning matters can be obtained from MTMC.

c. Maintenance.

(1) AMC major subordinate command item managers are charged with insuring the existence of organic depot maintenance capability and adequate commercial repair capability to meet the readiness requirements of approved forces for materiel items for which they have management responsibility.

(2) The source document for mobilization depot maintenance requirements data is the budget Army Materiel Plan, Part I. AMC major subordinate commands provide the US Army Depot System Command (DESCOM) with mobilization maintenance requirements data for selected materiel items. DESCOM develops and provides the depot mobilization plan indicating mobilization workload distribution to the appropriate depots, according to the prime and secondary depot maintenance mission assignments directed by HQ, AMC. Mobilization maintenance workload beyond the capability of the assigned depot is redistributed by DESCOM to other organic depots, or if beyond the capability of these other activities, is reported by DESCOM back to the National Inventory Control Point (NICP) as candidates for contract overhaul. The industrial preparedness activity at each major subordinate command includes these candidates in its planning with industry.

(3) The depot maintenance mobilization plan should include major and secondary items, ARNG and USAR requirements, interservice and interdepartmental orders, and essential contracts.

d. Inventory Management and Supply Depot Operations.

(1) Mobilization stocks constitute a major portion of the Army's supply inventory. Mobilization stocks are intended to sustain combat operations until normal resupply can be established.

(2) Mobilization Reserve requirements are computed in accordance with levels stated in AR 11-11, the unit deployment schedules to the combat area, the requirements set forth in the applicable unified commander's OPLAN or a mobilization plan, and special guidance and policy provided by DA. In a limited war, separate mobilization Reserve requirements computations are based on guidance contained in Part Six, Materiel Annex to the Five-Year Defense Program (FYDP) and applicable amendments.

(3) The War Reserve Stockage List (WARSL) is an automated listing by DESCOM of principal and secondary end items authorized for stockage in war reserves for use by US forces. Not listed but also authorized for stockage are functional components and repair parts necessary for mobilization support of WARSL end items. Items contained in the WARSL are recommended by MACOMs as essential for the operational effectiveness of combat, combat support, and/or combat service support forces. Code One (RICC 1) items authorized for the appropriate oversea commands, FORSCOM, and TRADOC are included in the WARSL by DESCOM. Selection of strategic communications items and associated communications security materiel is based on recommendations by Commander, USAISC, and approved by DA. The Surgeon General reviews and approves all medical items included in mobilization reserves. Criteria for selection of items for the WARSL are stated in chapter 8, AR 710-1. The WARSL is revised annually by AMC, approved by DA, and published in SB 700-40.

(4) Total stockage of mobilization requirements is rarely achieved nor is it considered essential. Shortage of funds may prevent obtaining adequate stocks for any one year and a large portion of the Army inventory is always undergoing technological change contributing to this situation. Thus, many items become obsolete within a very short time. Other items deteriorate over a period of time. To prevent the buildup of large quantities of items that may become obsolete or unserviceable, the item manager must apply good judgment as well as provide for accelerated acquisition of such items when the need arises. Adequate measures to protect mobilization reserve stocks must be taken to insure replacement in kind or equal value from operating stocks or funds when mobilization stocks are issued. Also important is the provision for insuring serviceability by care of supplies in storage and prompt rebuild direction for all unserviceable items in mobilization reserves.

(5) Mobilization stocks are combined with operating stocks to permit rotation as a safeguard against deterioration. Stock levels are not permitted to drop below the total earmarked for mobilization except under unusual circumstances. Temporary use of mobilization reserves in peacetime is authorized by paragraph 8-14, AR 710-1.

e. Acquisition.

(1) Under an executive declaration of emergency, an orderly transition to all-out acquisition of defense materiel to provide combat service support to US military forces and its allies is essential. Under this condition, the utilization of the Defense Production Act is authorized, negating the need for formal advertising and competitive acquisition. Mobilization planning for Army acquisition activities is developed in accordance with AR 700-90 and DOD/DA budget guidance. In the event of mobilization, such matters as accelerated delivery, expansion to multishift rates, establishment of priorities, and competition from other military services, Government activities, and private enterprise will pose many problems for acquisition personnel. A significant increase in acquisition and production activities to expedite the delivery of combat materiel will also require an increase in supporting elements.

(2) In planning for mobilization, the commander of an Army activity having acquisition responsibilities should:

(a) Provide for a staff knowledgeable in acquisition responsibilities, procedures, and policies, and make provisions for continuity in the planning and execution of the program.

(b) Determine time-phased requirements of all US military services and allied forces based on scenarios, force levels, and usage data provided by higher authority.

(c) Determine current asset position to include dues-in from current production contracts and overhaul schedules.

(d) Determine shortages by comparing requirements with available assets.

(e) Where shortages exist, negotiate contracts with current and recent producers for estimated additional quantities required, investigate the possibility of increased deliveries under current contracts, determine capabilities and potential of planned procedures; and investigate the use of Government-owned industrial plant equipment and facilities, to include Reserve industrial plants.

(f) Conduct plant visits to validate capabilities of private industry to meet urgent military requirements, especially in the areas of acceler-

ated or expanded deliveries and additional equipment needs.

11-7. Installation Operations Requirements

a. It can be assumed that as a result of partial or full mobilization, the majority of the increased strength will reside on a military installation increasing the requirement for supporting services. Mobilization planning must provide for this increase. Each element of the DA is required in accordance with AR 500-10 to determine its requirements for nonindustrial facilities not under Army control to support force levels approved by the Secretary of Defense. Planning for restoring inactive installations should provide sufficient leadtime and previously consummated contracts for facilities engineering aspects of the operation as well as staffing and equipping the installation to conduct operations.

b. The following general policies applicable to various installation support services must be considered by the mobilization planner.

(1) Family housing requirements will be met by utilization of existing onpost housing and maximum utilization of local community support. Substandard housing may be utilized for periods of less than 60 days. For periods greater than 60 days, responsible commanders should improve the facilities to adequate standards. Construction of additional family housing is not authorized except under emergency circumstances and as approved by DA. Planners should determine all current and potential housing on and off post, initiate planning for mobilization family housing requirements to include cost estimates, new family housing actions, and a vigorous program with real estate and community housing offices.

(2) Dining facilities must be expanded to provide for the increase in personnel occupying onpost housing including temporary dormitories, and for expanded and multishift operations. Branches and/or mobile eating facilities should be established as required.

(3) Post exchange, theater service, open mess, and service club facilities must be expanded to meet the needs resulting from increased military strength. Where additional facilities are required, consideration should be given to locating them within walking distance of troop housing concentrations.

(4) The establishment of unit or consolidated messes and officer field ration messes (for 100 or more officers) must provide for increased military population and workload buildup. This will also

consider multishift operations and the acquisition of adequate food service personnel. Normally, military personnel will be used to staff enlisted messes, but the use of civilian personnel or contract caterers for operation of both enlisted and officer messes should be considered.

(5) Troop Issue Subsistence Activities must be expanded as required to meet needs of additional military messes. Commissaries will be expanded or established upon approval of Commander, TSA, acting under guidance from HQDA, to provide service to eligible patrons. Services provided must be fully responsive to customer needs, and sales hours established to meet the needs of the majority patrons. Planning should consider requirements of additional personnel with required skills and the establishment of annexes where required. MACOM and installation plans dealing with commissary support will be made available to TSA or its subordinate regions on request.

(6) Laundry and drycleaning facility expansion projects must be planned to meet requirements for mobilization. Requisitions for additional equipment should be prepared in advance for submission when specific emergency conditions are declared. In addition to Army-operated facilities the availability of contract services should be evaluated. When required by health and sanitation needs, provisions for inclusion of decontamination services should be included in plans.

c. Each element of the installation should determine what will be needed to meet mobilization requirements. The acquisition, training, and retention of personnel with adequate essential skills as a base for expansion is mandatory. Requisitions should be prepared in advance for submission when specific emergency conditions are declared to accomplish planned activations, reorganizations, mobilizations, and conversions. Plans should be reviewed and updated annually.

11-8. Management Information Systems

a. Logistics operations throughout the Army are largely dependent upon automatic data processing (ADP) systems and facilities. Serious failure and/or prolonged interruption of these systems and facilities during a period of mobilization and/or war emergency could immobilize the logistics support to Army forces. Increased demands, workloads, and dependence on ADP facilities which occur in a transition from peacetime to wartime operations could seriously impact on the capability of support commands to respond to the mobilization effort. These increased ADP requirements can be assumed to occur beginning with the very initial phases of a limited or general mobilization.

b. A significant percent of the ADP workload is represented by reporting requirements. These reports are necessary to management and will increase as a result of mobilization. Since many of the reports are automated, this will cause an increase in ADP requirements.

c. To insure that the anticipated increase in the ADP workload is handled efficiently and effectively and ADP support needed for essential management functions is continued without interruption during the mobilization or emergency, it is necessary to establish the required order of priority and essentiality. Essential ADP applications which must be processed, essential reporting requirements (machine or manually prepared) which must be continued and those which can be discontinued or temporarily suspended during mobilization or periods of emergency should be identified.

d. All applications essential to the mobilization effort are assigned an order of priority. Highest priority is given to the operational systems which support essential war functions identified in appropriate war emergency plans. Established priorities must be documented as required by paragraph 4-20a, AR 18-7.

e. ADP equipment configurations should provide for and insure a capacity to process all essential current applications, predictable future peacetime workloads, and mobilization requirements. To meet expanded requirements resulting from mobilization, the equivalent of one daily shift should be reserved. While this reserve capacity should be used only for the purpose intended, it may be used for ADP sharing provided the servicing ADP reserves the right to cancel the sharing arrangement, and it may be used to meet unforeseen requirements. If these requirements continue for a long time or are permanent in nature, the priorities of current applications should be reviewed to confirm their essentiality and permit rescheduling or to determine the need for additional ADP.

f. Reports, automated or manually prepared, not essential to management of operations during mobilization should be suspended or eliminated. Others should be reviewed for the possibility of reducing the frequency of submission; the number of data elements; the numbers of reporting agencies; and/or using past experience data in lieu of actual or validated data.

g. Plans and procedures for contingency conditions should be developed in accordance with requirements stated in appropriate emergency plans. These plans and procedures should be tested periodically to determine their adequacy to support the military operation plan to be executed.

CHAPTER 12

INDUSTRIAL PREPAREDNESS PROGRAM

12.-1. Introduction

a. A viable industrial base that can respond adequately to wartime demands must be maintained. Since the United States must be prepared to react in support of its worldwide treaty commitments, it may have to employ its general-purpose forces anywhere in the world against one or more nations under various circumstances. Planning for logistics support must consider such factors as the length and intensity of combat, the size of combat forces committed, the support required to be furnished to allies and the support that can be furnished by allies.

b. For high-intensity wars of short duration, it is necessary to have adequate supplies on hand to support the operation until its conclusion. Except for those items which are consumed in peacetime as well as wartime, the conversion of industrial capacity to production of military peculiar war equipment such as ammunition, weapons, and the like, could not be accomplished. Current planning for contingency operations such as involvement as part of the North Atlantic Treaty Organization (NATO) against the WARSAW Pact nations provides for pre-positioning of war reserve stocks to provide support until resupply from the Continental United States (CONUS) is established. Even the CONUS resupply support will come initially from prestocked war reserves. This will continue until wartime production equals wartime requirements.

c. In peacetime the logistics planners must determine what resources are required to support US peacetime national strategy and what is required to convert our industrial capacity to a wartime posture as quickly as possible. Several elements must be considered by these planners—initial allowances; basic and mission loads; combat essential items; length of pipeline overseas; oversea storage objectives; transport capabilities; wartime consumption; wartime production; and status of the production base. The objective of this planning is to provide support to military operations on an indefinite basis once hostilities begin regardless of where US forces may deploy. Since it is not feasible or economical to have stockpiles of sup-

plies to support all possible conflicts, the military services must plan with industry to rapidly convert to needed wartime production. This is the basis for industrial preparedness planning (IPP).

12-2. Department of Defense (DOD) Program

a. The Secretary of Defense was assigned certain emergency preparedness functions under Executive Order 11490, 28 October 1969. To carry out his responsibilities, the Secretary of Defense in DOD Instruction (DODI) 4005.3 directed the publication of the DOD Industrial Preparedness Production Planning Manual (DOD 4005.3 M). This manual assigns functional responsibilities; establishes operational procedures for planning; and prescribes terms, DD forms, reporting procedures, and security standards for protection of plans.

b. DODI 4005.3 states as DOD policy that each DOD component is responsible for selection of items necessary for its particular IPP objectives. The DOD objectives for major weapons systems selection for planning is set at about 100 with each component limiting its selection of these systems to about 35. A further limit of about 2,000 items, including major weapons systems, is set for each DOD component. Items selected for planning constitute the Industrial Preparedness Planning List (IPPL). For each major weapons system selected, vertical planning (down through subcontractor) is mandatory. IPP is limited to end items or components essential to combat operational effectiveness, or the safety and survival of personnel and meeting at least one of the following criteria:

- (1) Long acquisition leadtime.
- (2) Additional emergency production capability required.
- (3) Continuous surveillance to insure an adequate production base.
- (4) Critical skills or specialized production equipment required.

c. Items are prohibited from selection for planning if they are:

- (1) Solely for comfort, convenience, or morale.

- (2) To become obsolete within 12 months.
- (3) Normally available from commercial sources in sufficient quantities to meet requirements.
- (4) Common to both military and civilian use (except combat rations) where responsibility for planning is assigned to other Government agencies.
- (5) Not mission oriented. IPP for mission-oriented items shall be limited to reduction or elimination of M-Day stock deficiencies for these items.
- (6) Foreign production sources other than Canada will not be used in developing IPPs.

d. Calculation of requirements for selected planning items is accomplished annually based on the force levels and other planning guidances issued separately in the Logistics Procurement and Planning Guidance (LPPG) by the Secretary of Defense.

e. In planning for production of selected items, preference is given to privately owned facilities. Government-owned facilities are included in the industrial base to provide the resources not available from private industry or where national security or quick response is necessary. DOD Directive 4005.1 outlines the policies and procedures for development of DOD component instructions. In addition to production base facilities, DODI 4005.1 also provides for the existence of adequate commercial maintenance and repair capability to support items of materiel of approved forces for which a depot capability within the components does not exist.

12-3. The Army Industrial Preparedness Program (AIPP)

a. The AIPP implements the DOD program described previously for the development and maintenance of an industrial-base capable of supporting approved forces in current and future military operations. This involves the:

- (1) Planning, programming, and budgeting for the acquisition, production, and maintenance of military materiel under current and emergency conditions.
- (2) Performing the acquisition, production, and maintenance for selected military items critical to the support of approved forces specified by DA for preparation of part I of the Army Materiel Plan (AMP).
- (3) Managing industrial production and maintenance facilities, to include the acquisition, expansion, construction, rehabilitation, modernization, and layaway or disposition of plants and equipment.

(4) Formulating, justifying, and defending plans, programs, and budgets for research, development, test, and evaluation (RDTE) and acquisition of materiel from procurement appropriations (PA).

b. The objective of the AIPP is to develop, maintain, and retain the readiness of the Army industrial base to support the military materiel requirements of approved forces.

c. The AIPP consists of:

(1) IPP which is conducted to insure that an adequate industrial base is established, maintained, and retained to be responsive to military materiel requirements in the event of an emergency.

(2) The Production Base Support Program (PBSP) which provides support for the development, maintenance, and retention of an efficient and effective industrial base.

(3) Industrial preparedness operations (IPO) which are conducted to sustain the operational base.

d. IPP involves the assessment of the capability of the industrial base to support peacetime and emergency operations; the determination of requirements for the acquisition and production of selected critical items of military supplies and equipment to support military requirements; and planning with industry to insure adequate procurement, production, and maintenance capabilities to meet support requirements.

e. The production base is made up of Government-owned plants and Government-owned equipment in the hands of private contractors, and privately owned and operated facilities. Private industry is considered the foundation for producing military materiel. Government facilities and plant equipment packages are included in the base to supplement, where necessary, production from private industry. This complex in terms of Army use considers two distinct categories of facilities. First is that group of private producers from which a multitude of items common to the needs of both the Army and civilian economy are purchased. These items include construction, communications, electronics, and other types of equipment readily adaptable for military use. The other is the facilities needed to produce equipment that do not have civilian counterparts such as tanks, missiles, large caliber weapons, and military-peculiar ammunition. Private ownership of this latter category is virtually precluded because, during periods of limited demand, the private contractor could not afford to maintain an idle plant. For this category

the Army must plan for adequate, modern facilities, RDTE activities, improved manufacturing techniques, production lines, reserve of skills and technology in manufacturing military items, and a rapid reaction capability to fill urgent military requirements. The status of the facilities in both of these categories and the actions required to improve the readiness posture of the base for production and maintenance of IPPL items is depicted in a Production Base Analysis (PBA) prepared annually by US Army Materiel Command major subordinate commands.

12-4. Army Policy

a. Department of Army (DA) looks to private industry to provide to the maximum extent the materiel, supplies, and services required to support approved forces. However, the need to augment the capacity of private industry is recognized; thus, some Government-owned capability is retained as stated in AR 700-90. These provide:

- (1) RDTE activities.
- (2) Process engineering activities including:

(a) Development of improved manufacturing techniques.

(b) Establishment of pilot/prototype production lines for manufacture of new military items being introduced into the system, or to test advanced process techniques for the production of munitions.

(3) A reserve of skills and technology in manufacturing military items to assist in private industry during initial phases of mobilization.

(4) A flexible rapid reaction production capability to fill urgent requirements for military materiel not obtainable from private industry in time to meet required delivery dates.

(5) Short-run production capability for low-density military items, components, assemblies, subassemblies, and parts where manufacture by private industry is uneconomical or unresponsive.

b. Development of new privately owned capacity is encouraged where neither organic military production nor maintenance capacity exists.

c. DA provides for sustained industrial preparedness for production and maintenance of military items for approved forces.

d. DA insures development of adequate information to assess the industrial-base capability to support peacetime and emergency requirements.

e. A 2-year time frame (24-month delivery schedule; i.e., M-day through M + 24 months) is the base of planning with industry and is updated annually, or when significant changes warrant up-

dating. For planning purposes, D-day and M-day are considered to occur simultaneously on the first day of each fiscal year.

f. Staff planners will insure coordination between current acquisition maintenance operations and the development of the IPP.

g. Alternate sources are established when economically justified, directed by higher headquarters to alleviate dependency on sole sources, or to provide dispersion.

h. IPP is initiated early in the acquisition process to insure adequate support.

i. IPP will insure adequate commercial maintenance repair capability for items issued to approved forces for which there is no organic depot maintenance capability.

j. The IPP will provide for expansion of the industrial base when commercial capabilities are independent or the best interests of the Government are served.

k. IPP may be used to assess unprogrammed increases in materiel for contingencies short of full mobilization.

12-5. Responsibilities

a. Policy responsibility within Headquarters, Department of the Army (HQDA) is assigned to the Office of the Deputy Chief of Staff for Research, Development, and Acquisition (DCSRDA). Within that office, the Plans, Policy, and Test Division of the Materiel Plans and Program Directorate is the focal point for interpreting DOD guidance and formulating DA policy and implementing instructions for IPP. Other DA Staff elements coordinate with the Plans, Policy, and Test Division, DCSRDA on matters of mutual interest. The DA role, however, is primarily policymaking. The operational responsibilities are assigned to the Commander, AMC.

b. HQ, AMC, under the general guidance of HQDA, manages, controls, and executes IPP for DA. Management and staff supervision responsibilities within HQ, AMC are assigned to the Assistant Deputy Chief of Staff for Industrial Preparedness in the Office of the Deputy Chief of Staff for Production. Operational aspects of IPP are delegated to the several staff offices having primary interest in the functional portions of the planning. These functions include:

(1) Computation of current and emergency requirements.

(2) Development of IPPs to acquire and produce selected materiel.

(3) Insuring development, maintenance, and retention of an adequate base for future acquisition actions.

(4) Preparation, publication, and distribution of the Army PBA and the Army portion of the DOD IPPL.

(5) Integration of all program elements of the AIPP to support current and emergency requirements.

(6) Integrating inventory management for secondary items and repair parts to support mobilization requirements for IPP principal items.

(7) Planning with industry for depot maintenance mobilization requirements that AMC cannot perform with organic capability.

c. AMC MSCs nominate items for the IPPL based on DA-furnished critical items list (DACIL). The MSCs also compute mobilization maintenance requirements for principal items and select sources for prime contractor planning or delegate this function to an Armed Services Production Planning Officer (ASPPO). If this function is delegated, the MSCs provide the ASPPO with mobilization production and maintenance requirements, technical data, and planning guidance for prime contract and subcontractor planning. The MSCs review completed plans for reasonableness, accuracy, and sufficiency; furnish mobilization requirements for items to be acquired by other DOD components; provide results of planning with industry to other DOD components; and notify ASPPOs when to cancel, extend, or revise planned mobilization acquisition or maintenance schedules.

d. The US Army Industrial Base Engineering Activity (IBEA) provides technical coordination and assistance to HQ, AMC and the AMC major subordinate commands in IPP.

e. The US Army Depot System Command (DESCOM) develops mobilization depot maintenance workload requirements based on guidance from HQ, AMC.

12-6. IPP Procedures

a. IPP is performed to determine realistic mobilization production and maintenance requirements of the Army and the efficient use of existing commercial and organic facilities to meet these requirements. The planning includes selection of combat essential major weapons systems, principal items components, subassemblies, and secondary items for the IPPL in accordance with criteria established by DODI 4005.3. Secondary items for IPP in addition to the criteria stated previously are designated selected item management-expanded (SIM-X) items (i.e., secondary items selected for intensive management). The items selected must

support principal items on the IPPL. Exceptions to these criteria must be approved by HQ, AMC. Planning with industry for mobilization production and maintenance of certain materiel, as stated in paragraph 12-2c, is prohibited.

b. Planning for D-day stockage levels and the investment in base facilities to overcome the deficit in post D-day production/maintenance capabilities is accomplished in accordance with DA Planning and Policy Guidance (PPG). The most economical mix of stocks available on D-day and post D-day production capability is determined by economic analysis. Stocks available on D-day should be capable of supporting the operational forces until production costs meets the sustained combat requirements. The Army Acquisition Objective (AAO) is the basis for determining D-day stockage levels, investment planning, and retention of the industrial base and production rates. Mobilization production requirements for principal items are expressed as monthly rates in part I of the AMP. Mobilization production requirements reflecting post D-day consumption data are annotated in volume I, Production Base Analysis, for each item. Industrial base planning for acquisition of base facilities where sufficient commercial capabilities do not exist is identified in the AMP by force level guidance.

c. Mobilization depot maintenance requirements are determined by AMC MSCs. This maintenance is limited to major weapons systems/principal items listed in the IPPL. Maintenance requirements which cannot be performed with AMC capabilities and are to be accomplished commercially are stated as monthly rates projected over a 3-year period. Requirements are submitted biennially (on even-numbered calendar years) by AMC MSCs to the DESCOM. DESCOM develops depot maintenance mobilization plans distributing the workload according to mission assignments to appropriate AMC depots. The plans are provided to the depots for review and determination of assigned maintenance workload beyond their capabilities to accomplish. DESCOM is advised by each depot of its expected increased capacity and the workload beyond its capacity. HQ, AMC is provided the additional requirements by DESCOM. After review, HQ, AMC provides these requirements to the appropriate MSC for assignment to their industrial preparedness activities for planning with industry. An analysis of mobilization with industry is included in the annual PBA submission by each MSC.

d. Both horizontal and vertical planning with industry is performed.

(1) Horizontal planning views the total domestic capability against the total requirements of all DOD components. It covers a wide range of items including military end items and the components that support these items. Where the end items and/or components are used by more than one military service, one service may be assigned the responsibility for planning with input received from the other services.

(2) Vertical planning is mandatory for all major weapons systems, except mission-oriented items, to insure equitable distribution to subcontractors or requirements by prime contractors for critical assemblies, subassemblies, and components. This planning is extended from the prime contractor down to subcontractors of each critical product area. This planning should show the procurement transaction impact with industry under emergency conditions.

12-7. Industrial Preparedness Planning List

a. The IPPL is an annual publication which indicates those major weapons systems, principal items, and components, together with the using DOD component, which have been selected for planning. The basis for the IPPL is the DA Critical Item List (DACIL). In addition, the AMC MSCs are responsible for nominating to HQ, AMC items to be considered for inclusion in the IPPL. Copies of the IPPL are furnished annually by HQ, AMC to HQDA, other military services, and Defense Logistics Agency (DLA) and include principal items which require separate planning. Cards are submitted annually by the MSCs to the AMC Logistics System Support Activity (LSSA) which prepares listings for review by the originator, HQ AMC and IBEA. The IBEA provides engineering and technical support and guidance to the MSCs during preparation of their lists. IBEA then reviews the lists furnished by LSSA and furnishes corrections to LSSA and HQ, AMC. HQ, AMC, after its review, approves the listing furnished by LSSA and returns the list to LSSA with guidance for publication and distribution of the IPPL. Copies of the IPPL are furnished annually by HQ, AMC to HQDA, to other military services and to the DLA.

b. The IPPL consists of three sections. Part I is an index by nomenclature; Part II lists the item and its planned supporting components; and Part III is a cross reference by Item Control Number.

c. The military services and DLA request each other to mobilizational production plan those items procured by each respective component. Intraservice planning is accomplished as necessary to provide support item planning. The MSCs initi-

ate procurement planning action on these requirements as soon as possible and provide feedback of the IPP actions directly to other components. The MSCs review the IPPLs received from other DOD components to determine that planning requirements have been recognized. The importance of adhering to the schedule for submission of data is emphasized to insure that those responsible for planning any acquisition actions have the required data upon which to act.

12-8. Industrial Preparedness Measures (IPM)

a. An important element of IPP is the identification of those deficiencies in the industrial base that would contribute to the inability of the producer to deliver required items after mobilization is declared so that action can be initiated to improve production capacity, reduce current production problems, or provide for production by new producers. IPMs are the measures or actions designed to shorten post M/S-day leadtime or to increase production/repair capacity for planned items and critical components.

b. The Army fiscal structure provides, in the Procurement, Army (PA), Operation and Maintenance, Army (OMA), RDTE Appropriations, the means for acquiring facilities, improving existing facilities, initiation of pilot line production projects, plant equipment packages, stock piling critical parts, determining required tools, equipment, and skills and maintenance of approved industrial plants and equipment.

c. The IPMs adequately supported by DD Form 1519 are identified and described in the PBA. The proposed IPMs become the basis for the AMC PBA Summary Brochure.

12-9. Production Base Analysis

a. The PBA published annually by IBEA, shows the status of the industrial base that is required and is currently available for production and depot maintenance of IPPL items in an emergency. Each AMC MSC, based on guidance from HQ, AMC and IBEA, prepares a PBA in two volumes annually and submits them to HQ, AMC.

b. Volume I of the PBA, Item Analysis, contains a description of the planning activity mission; the range of items planned; the nature of the supporting industrial base for production of planned items; a statement of planning assumptions; and a summary of recent changes, accomplishments, problem areas, and proposed actions regarding the industrial base. An analysis of planned items and maintenance mobilization requirements together

with associated facilities is also included. An item analysis form is completed for each principal item on the IPPL.

c. Volume II, Facility Analysis, contains management information on both Government-owned and contractor-owned facilities and the active and mobilization reserve IPE associated with the facilities. This volume also includes a description of the condition of plant equipment packages, modernization plans to improve readiness and increase the capacity of the facility, and the status of expansion plans for the facility. A facility analysis is completed for each major end item producer of IPPL items.

12-10. Register of Planned Emergency Producers (RPEP)

This register identifies plants participating in the IPP and the ASPPO responsibility for these plants. Only the production and maintenance facilities of planned producers and those in the process of becoming planned producers at the prime and subcontract levels are listed. The register is published annually in three volumes by HQ, Defense Contract Administration Services (DCAS). Volume I is an alphabetical listing, volume II is a listing by geographical location, and volume III is a listing of the ASPPO. Plants are registered with DCAS under the procedures in DOD 4005.3M.

12-11. Production Engineering (PE)

a. *The Army.*

(1) Uses PE efforts to maintain and improve industrial preparedness by expanding manufacturing technology and translating new technology into practical production processes. Objectives include activities which improve productivity, reduce costs, enhance safety, eliminate or reduce pollution, conserve raw materials and energy, reduce leadtimes, develop multiple sources, find alternatives to production bottlenecks, verify various methods of production suited to substitute noncritical raw materials, or make other improvements.

(2) Encourages and promotes similar effort by private industry contractors.

(3) Production engineering involves:

(a) Producibility engineering and planning.

(b) Manufacturing methods and technology (MMT).

(c) The industrial modernization incentives program (IMIP).

(d) Engineering in support of items in production (ESIP).

(e) Post production engineering (PE).

(f) Value engineering (VE).

(4) The PE Program will support a modern industrial base capable of meeting current and future production requirements for Army materiel and Army managed items. The Army will evaluate technology needs by analyzing production and facility requirements and identifying those manufacturing operations that can and should (based on priority and return on investment considerations) be improved through PE efforts. Technology forecasting, cost driver studies, technology conferences and any other method available will be used to develop comprehensive plans for funding of PE effort. Emphasis will be placed on encouraging industry to undertake PE efforts on their own initiative using private funds. The DCSRDA establishes policy and plans, programs, and budgets for production engineering. The CGAMC plans, programs, budgets, develops procedures, manages, and reports on the execution of production engineering.

b. *Productivity Engineering Planning.*

(1) These are planning and engineering projects that start with feasibility studies and extend through prototype production to ensure that a specific end item or component is capable of quantity production. Producibility engineering planning projects develop cost effective manufacturing processes for a particular end item. They include the application of new or improved techniques, equipment, or materials to manufacture specific weapons systems, components, end items, and prototypes.

(2) They are financed by the Research Development Test and Evaluation (RDTE) appropriation as a part of the specific weapons system involved.

c. *Manufacturing Methods and Technology (MMT).*

(1) MMT projects assist the transition from development to full scale production and expand manufacturing technology by translating new technology into practical production processes. They provide for the development or improvement of manufacturing processes, techniques, and equipment to produce timely, reliable, and economical solutions for current or anticipated problems in the manufacture of materiel or for future acquisition. They produce information which defines, monitors, or controls processes and equipment used in manufacturing and maintenance operations. The program's objective is to significantly improve the productivity and responsiveness of the industrial base (to current, surge, and mobilization requirements) by:

(a) Aiding timely economical production.

(b) Ensuring advanced manufacturing processes, techniques, and equipment are available for reducing materiel acquisition, maintenance, and repair costs.

(c) Continuously advancing manufacturing technology to transition from research and development to full-scale production.

(d) Promoting capital investment and industrial innovation in new plants and equipment by reducing the cost and risk of improving manufacturing technology.

(e) Ensuring that manufacturing technologies are consistent with safety, environment, and energy conservation objectives.

(f) Widely disseminating manufacturing technology results.

(2) Policy

(a) Maximum potential benefits from each investment will be sought by ensuring that:

1 There is a well-defined requirement for technology which can be delivered in time to meet the requirement.

2 Anticipated investment results are applicable to more than one end item.

3 There is a specific plan to implement the results of the investment.

4 The potential for multi-DOD component sponsored investments has been investigated.

(b) The MMT program will not include projects that support basic research.

(c) MMT projects are to be used only when the feasibility of the manufacturing process has been demonstrated by experimental data.

(d) The Army will actively participate in the Tri-Service Manufacturing Technology Advisory group and will participate in joint service projects which benefit the DOD production base.

(3) Responsibilities. The CGAMC is responsible to:

(a) Maintain a continuing, identifiable MMT program in accordance with DOD 4005.1, 4200.15, 4245.6, and 5000.1.

(b) Maintain the following measures of MMT planning and execution:

1 Comparisons between the planned (budget and apportionment) and the actual use of funds.

2 Comparisons between the planned (at time of obligation) and the actual deliverable form investments.

3 Comparisons between the planned (at time of obligation) and the actual implementation of deliverables.

4 Records on the amount of activity designed to disseminate deliverables throughout the industrial base.

(c) Maintain a Manufacturing Technology Program Information System consisting of a centralized computer data base containing information of all planned, active, and completed investments managed and controlled in accordance with DOD Directive 4200.15 and 5000.19. (RCS DD-DRDE(Q) 1679).

(d) Provide timely information on end of contract briefings, completion of MMT tasks, and other appropriate MMT activities to the Manufacturing Technology Information Analysis Center (MTIAC).

(e) Establish procedures to assure that classified, proprietary, or competition sensitive information is not released to MTIAC.

(4) Funding

(a) MMT projects are financed by the RDTE appropriation and will meet the following criteria:

1 Be based on technology or equipment concepts proven by research or laboratory work prior to initiation of the project.

2 Result in new, significantly improved, or more economical processes, techniques, equipment, or production systems.

3 Results, whenever possible, in generic processes, techniques, or equipment functions.

(b) MMT funds may not be used for investments more appropriately funded by other means, such as:

1 Routine application of existing technology for the production of specific parts.

2 Investments specifically intended to change an end item's design.

3 Purchase of off-the-shelf capital equipment, unless it is required to establish the first-case application of the MMT deliverable.

4 Performance testing of materiel produced using MMT deliverables, except to validate the manufacturing process.

5 Implementation of manufacturing technology beyond the first case, factory floor application.

(c) The MMT program will not be used to fund the use of existing processes, techniques, and equipment to manufacture specific parts.

d. Industrial Modernization Incentives Program (IMIP)

(1) Description. IMIP is intended to overcome obstacles to increased capital investment to improve productivity and reduce acquisition costs in both private industry and government operated facilities. Two frequently cited obstacles to private industry productivity investments are program uncertainties and government pricing policies. Program uncertainties introduce risks which hinder investment amortization and long-term planning. Government cost based pricing policy may actually reduce profits as a result of the risks assumed to improve productivity and reduce costs. These obstacles tend to emphasize short-term profits and reduce the desirability of long-term productivity gains. Managers of government owned facilities do not have the advantage of profit incentive and often do not have sufficient funds to conduct analysis to identify worthwhile long-term productivity improvements.

(a) For private industry facilities, IMIP provides incentives to contractors to undertake capital investment programs based on a top-down overall factory analysis. This analysis ensures that capital investments are used to best advantage and that indirect and direct labor costs are affected.

(b) For government operated facilities, IMIP provides funds for analysis to identify long-term productivity improvement investments.

(c) For private industry facilities.

1 Incentives may be provided when the risks, benefits, and "usual" investment is involved and when the risks, benefits, and other factors show the incentives can be justified. All incentives available in acquisition regulations will be allowable in IMIP agreements. Principal incentives used other than IMIP are shared savings awards and contract termination protection which may be used separately or in combination.

2 Contract termination protection is the only incentive which effectively deals with the problem of program instability. Monitorship and control of the extent of unfunded government liability will be maintained.

3 Shared saving allows emphasis on real savings in the production of an item as opposed to weight guidelines which can tend to increase the density of capital machinery without realizing significant reduction in the cost of an item.

4 The focus of IMIP is the modernization of the entire facility and commitment to incremental improvements should be avoided when practi-

cal. Consequently, all projects should be considered allowable for inclusion after the contractor shows a creditable top-down overall factory analysis and improvement plan which demonstrates that real cost savings and productivity improvements can be realized. All facets of the factory must be considered, including indirect labor (overhead).

5 Audit procedures will be developed to document and compare costs and benefits. However, the lack of audit procedures should not eliminate a particular project from consideration if the overall modernization effort evidences an adequate benefit.

6 Weighted guidelines for fee rate determination should provide explicit and substantial allowance for assets employed when applied as an IMIP incentive.

7 IMIP incentives can include an explicit incremental allowance made for incremental investment in future productivity improvement. The allowance will be negotiated on a project basis, be reasonably related to the cost savings accruing to the government, and applied to all benefiting contracts. The risk that anticipated government business which is benefited may not materialize will be taken into consideration to the same extent that the same business is discounted in determining the forward pricing overhead allowance.

(d) For government operated facilities, IMIP provides funding to conduct top-down overall factory analysis and identify capital investments to improve productivity. The IMIP does not fund capital investments of any kind. The policies discussed in paragraph (1) generally apply. CGAMC is responsible for:

1 Managing the IMIP.

2 Auditing the IMIP and providing the the appropriate contracting officer to ensure savings are adequately reflected in contract prices.

3 Reporting IMIP as described in paragraph 3-10.

4 Private industry use of IMIP is funded by private industry. The government uses the request for proposal to request pricing with and without IMIP.

5 Government operated facilities use of IMIP is funded by the RDTE appropriation in the Industrial Preparedness program element.

(e) Engineering in Support of Items in Production (ESIP) and Post Production Engineering (PPE). ESIP and PPE encompass nonrepetitive special engineering and testing by the materiel

developer on items currently in production or those which have been accepted for operational use or introduction into inventory. ESIP and PPE activities include, but are not limited to, the following:

1 Investigating the causes of malfunctions not previously observed during development testing, first article testing, acceptance testing, or in operational usage of type classified materiel.

2 Uncovering suspected by undetermined defects in operational or stored materiel which is not newly manufactured (i.e., has been owned by the government for more than 60 days).

3 Reestablishing, on a one-time basis, the reliability of stored items which have become suspect due to malfunctions in like items issued to users.

4 Revising or establishing surveillance criteria, safe life criteria (except stock funded cannons and gun tubes), service life, shelf life of non-stock funded items, use criteria, or similar yardsticks for items currently in use or in inventory. Such effort may include test or operating data collection; performance or service evaluation; and analyses to establish or improve reliability, maintainability, or safety of type classified/adopted items.

5 Developing and maintaining the Technical Data Package (TDP) for an item in or out of production.

6 Correcting current production problems requiring engineering effort.

7 Developing data or performing preliminary investigations which may lead to a formal product improvement or engineering study.

e. Value engineering (VE). VE is performed to find the required function of Army systems, operations, facilities, equipment, and supplies at the lowest total cost consistent with requirements for performance, reliability, quality, maintainability, and safety. The appropriation financing the prime program will fund VE actions.

12-12. Active Facilities Management

a. The Army industrial base consists of both privately owned and Government-owned production and maintenance capacity. It is this base upon which the Army relies to meet its requirements in peacetime and under emergency conditions. If private industry does not have, cannot, or is not willing to develop the required capacity and for reason of economic benefits and national security considerations the best interests of the Government is involved, Government-financed production facili-

ties can be expanded, contractor-owned facilities can be augmented by Government-owned facilities or Government-owned facilities provided to meet valid requirements. There are various authority levels for GOGO and COCO installations. For new construction under \$200,000 the installation commander has approval authority; over \$200,000, it must be placed before Congress.

b. HQDA, in accordance with policy and direction from the Office of the Secretary of Defense, provides policy and guidance to the Chief of Engineers, Commander, AMC, and the AMC agency for Munitions Production Base Modernization and Expansion (MPBME). DA also plans, programs, and budgets for industrial base facilities and monitors the Army Facilities Program and the commercial and industrial-type activities program. The Chief of Engineers is responsible for planning and supervising the acquisition of facilities for production and maintenance. The MPBME is the centralized management authority for the planning direction and control of the MPBE Program. AMC, based on guidance and direction of HQDA, plans, programs, and budgets for industrial base facilities. Staff offices within HQ, AMC are responsible for staff supervision of those aspects of the program within their areas of interest. AMC MSCs manage those parts of the production base support program within their assigned commodity areas. They also plan, program, budget, execute, and report provision of industrial facilities projects. IBEA reviews and evaluates all projects and provides comments and analysis to HQ, AMC.

c. Programing for production base facilities and maintenance base facilities is based on requirements stated annually in the AMP. The industrial base is financed by PA, OMA, Military Construction, Army (MCA), or RDTE appropriations, depending on the type facility, equipment, or project involved.

d. Provision of Industrial Facilities (PIF) projects are used to provide the Army's segment of the production base. PIF projects are of four types:

(1) Initial Production Facilities (IPF) projects provide production facilities needed to support low-rate initial production of systems, end items, or components.

(2) Modernization projects are used to improve industrial facilities through replacement, modification, rearrangement, or addition of capability to achieve economic, quantity, time, or safety advantages.

(3) Support projects maintain the designed capacities and capabilities of Government-owned fa-

ilities through equipment replacement or correction of normal deterioration through repair or limited modernization. IPE replacement is included in these projects.

(4) Expansion projects provide facilities to create new capacity or add to existing capacity.

e. Commanders of AMC MSCs, research and development (R&D) commands, and other major subordinate commands determine real property requirements and plans and programs for acquisition or for the activation of inactive facilities to support assigned missions and advise the Office of the Chief of Engineers, DA or the appropriate district engineer of the requirement for real estate planning and reporting. The district engineers are responsible for design and construction of facilities within their assigned areas. AMC MSCs also review existing Government-owned facilities to determine efficiency of utilization and the need for retention to meet mobilization production requirements. These commanders also review Government-owned Government-operated (GOGO) real property facilities for retention or disposal. In addition to reviewing facilities for retention or disposal, AMC major subordinate command, and in turn HQ AMC, review modernization and replacement facilities projects.

f. DA must maintain an active production base to supplement civilian industry capabilities to meet current production requirements. To carry out this policy, subordinate Army commands are charged with managing the elements of the active production base and establishing maintenance and repair programs so that all plant equipment can perform satisfactorily and the base is responsive to Army peacetime and emergency need. Section VI, AR 70090 outlines the policies and procedures to be used in managing the Army's active production base.

12-13. Inactive Facilities Management

a. A continuous program is in effect to evaluate for retention those facilities and plant equipment packages and place those needed in a layaway status kept in a state of readiness for operation as required by the anticipated mobilization needs.

b. In planning for layaway of facilities, consideration is given to the length of time the end items produced will remain in the inventory; the mobilization requirements for this item; the stock status of items; cost of stockpiling versus retention of facilities; other production sources startup time for facility after reactivation; and future availability of materiel to support the facility.

c. To meet required responsiveness, three states of readiness are identified in layaway planning:

(1) High—those required to initiate production by M + 90 days.

(2) Medium—those required to initiate production between M+ 90 and M + 180 days.

(3) Low—those required to initiate production after M+180 days. In this state maintenance of buildings, support equipment, roads, and grounds will be the minimum required to preserve operational capability and safety conditions and eliminate hazardous conditions.

d. For selected layaway projects, consideration is given to dispersion and protection of vital production capacity. In determining the location of plant equipment packages, consideration is given to outside versus dispersed storage sites, time required for reactivation, and the costs for moving and losses due to movement. It is preferred that plant equipment packages be stored in place or as close as possible to the last place they were operated. Equipment should be stored in DOD or Government-operated storage space wherever possible. If needed for reactivation of a facility, other essential equipment such as special tools/special test equipment, training aids, materials handling equipment, and major office equipment items may be stored as part of the plant equipment package. After plant equipment is placed on layaway status, a continuous program will be conducted to improve and maintain these packages in the highest state of readiness that can be economically justified.

e. Controls are established by responsible commanders on plant equipment to provide for screening the Defense Industrial Plant Equipment Center (DIPEC) for IPE that can be used to fill voids or replace unserviceable or obsolete equipment. Plant equipment packages are reviewed to see if retention criteria are met. Before layaway, each item is tested to determine its condition code. All equipment is placed in satisfactory operating condition before being placed in layaway. If equipment is placed in layaway status with uncorrected deficiencies, these will be identified and recorded and followup action will be taken to replace or rehabilitate unserviceable equipment. Technical assistance can be obtained from DIPEC for inspection of equipment to determine its condition code.

f. The commanders of Army installations are required to conduct annual inspections of each Departmental Industrial Plant Reserve (DIPR), National Industrial Plant Reserve (NIPR) and Reserve Commercially Acquired Plant (RCAP) for which they have been assigned jurisdiction or inspection responsibility. These inspections determine the actual condition of buildings and equip-

ment; capabilities to respond to assigned missions; and the adequacy of maintenance. A report is furnished to IBEA each year for review and submission to HQ, AMC. HQ, AMC approves the reports and makes distribution. The reporting procedures are described in section IV, chapter 5, AR 700-90.

12-14. Defense Priorities and Allocations Program

a. The Defense Production Act authorizes the President of the United States to establish priorities and allocations that insure the acceptance and performance of defense contracts and orders by appropriate segments of industry. The Presidential authority for policy development was re-delegated to the Federal Emergency Management Agency (FEMA) who re-delegated administration to the Secretary of Commerce. The Department of Commerce issued the Defense Priorities and Allocations System (DPAS) Final Rule in the Federal Register on 30 Jul 84. This final rule was effective 29 Aug 84. The DPAS is binding on industry and government personnel and is the legal basis for obtaining preferential treatment and timely delivery on defense contracts and orders. The new DPAS final rule also contains a new Delegation of Authority to the Secretary of Defense (Note: The Secretary of Defense has not yet re-delegated the new authority. Priorities and Allocations actions currently in process are within the scope of the previous delegation of authority.) The DPAS prescribes the rules and procedures for defense activities and private industry covering assignment of industrial priorities and allocations to authorized contracts and orders that promote national defense, including acceptance or nonacceptance.

b. DODI 4400.1, the DOD priorities and Allocations Manual (PAM), implemented as AR 715-5, provides guidance to DOD components and DA to carry out Secretary of Defense responsibilities. AR 715-5 describes the various procedures, reports, and forms required by the DOD Priorities and Allocations Program.

c. Within the Office of the Secretary of Defense, the Assistant Secretary of Defense (Acquisition and Logistics) has been delegated the priorities and allocations authority with permission to re-delegate the authority to issue ratings and allotments to DOD components. Pursuant to this delegation of authority, the Secretaries of the military services and the directors of defense agencies have been given the authority to apply or assign to others the right to apply DX and DO ratings and allotment numbers to contracts or delivery orders needed to meet DOD research and development; procurement and production; maintenance and construction program objectives.

d. Department of the Army (DA) priorities, and allocations authority and responsibilities are delegated and assigned to the Commander, AMC, who exercises DA staff management, direction and control of DA operations related to the DOD priorities and allocation program. This includes assignment of priorities to contracts and orders for authorized defense programs. All DA procuring activities establish within their areas of responsibility the procedures to assign appropriate defense priority ratings to all contracts, subcontracts, and purchase orders. They also establish procedures to advise contractors, subcontractors, and suppliers of their rights, violations, and the DPAS procedures and the provisions of the DOD Priorities, and Allocations Manual (PAM).

e. "DO" and "DX" are rating symbols used to designate industrial priorities for acceptance and performance of certain contracts and orders in preference to others. DX-rated contracts and orders take precedence over DO-rated and unrated contracts and orders. All military procurement, except those items prohibited from being rated (see AR 715-5) are assigned a rating and an identification code which identifies the item to a DOD claimant program.

12-15. DOD Master Urgency List (MUL)

a. The DOD publishes periodically a list of items required to support national defense and security that have been determined to require special attention. Each military service and other DOD component nominates, in accordance with DODI 4410.3, those items of the highest urgency for inclusion in the MUL. The items nominated are reviewed by appropriate Offices of the Secretary of Defense (program considerations), the Joint Chiefs of Staff (military importance considerations), and the Office of the Assistant Secretary of Defense for Acquisition and Logistics (production resource considerations). The Assistant Secretary of Defense for Acquisition and Logistics is responsible for submitting the MUL to the Secretary of Defense for approval. When approved, the MUL provides the basis for determining relative program precedence for assignment of resources. The MUL is used as a guide by the Federal Emergency Management Agency, the General Services Administration; Department of Commerce; the DOD components; the Department of Energy; and the Canadian Department of Supply and Services to identify relative ranking of high-interest items and inadequacies in the industrial base that affect the most urgent programs.

b. For national and military urgency categories have been established in the following order of precedence:

(1) *BRICKBAT*. These items have been selected as being of the highest national priority because of key political, scientific, psychological, or military objectives. These programs require approval by the President. They are assigned a DX industrial priority rating and carry a higher priority than items in other categories. All *BRICKBAT* items have equal priority.

(2) *CUE-CAP*. Items selected for this category have been determined to be of the highest DOD priority because of military essentiality and criticality. A *CUE-CAP* program is assigned DO priority rating and given a relative priority number within that category. For example *CUE-CAP 15* indicates there are 14 items in this category of higher priority. *CUE-CAP* programs are approved by the Secretary of Defense.

(3) *DRY-DAY (Reserved for Emergency Use Only)*. These programs are considered for the support of expanded resources. These items are also assigned DO ratings and a relative order of priority. They are approved by the Secretary of Defense.

(4) *ELK-EAR (Reserved for Emergency Use Only)*. Programs in this category are considered desirable to support war reserve requirements. They, too, are assigned DO ratings and relative priority and are approved by the Secretary of Defense.

c. Currently, the MUL consists only of items within the *BRICKBAT* and *CUE-CAP* categories.

The other categories will be used if necessary in an emergency.

d. Items remain on the MUL only so long as special attention is required. Periodic reviews are made by the DOD components and other program participants to determine that they meet the criteria for selection and support the objectives of DOD as stated in the Joint Strategic Planning Document and the objectives of the military departments. Those that do not meet the criteria stated in DODI 4410.3 and AR 700-90 should be promptly removed from the list.

e. Each DOD component and participant designates a single point of contact to coordinate urgency actions.

f. Army, MUL nominations are initiated by the Project/Program/Product managers and item managers who prepare nominations for the MUL based on higher echelon criteria and other specific guidance from HQ, AMC. These nominations are reviewed, analyzed, and approved by HQ, AMC for transmittal to HQDA. HQDA reviews nominations submitted to insure that Department of the Army Master Priority List (DAMPL) priorities are integrated with approved MUL programs and that only the most urgent Army programs are nominated to DOD for the MUL. If appropriate, HQDA initiates nominations for the MUL and establishes internal DA policies for the use of the MUL. Procedures for nominating Army programs for the MUL are outlined in AR 700-90.

g. In the event of mobilization, other items are reviewed by appropriate Army elements and HQDA for integration into the MUL.

CHAPTER 13

MILITARY ASSISTANCE TO CIVIL AUTHORITIES

Section I. GENERAL

13-1. Introduction

There are numerous situations and established plans to provide assistance to civil authorities by the Department of Defense (DOD).

a. Domestic Emergency. The term “domestic emergency” includes any or all of the emergency conditions defined below.

(1) *Civil Defense Emergency.* A domestic emergency disaster situation resulting from devastation created by an enemy attack and requiring emergency operations during and following attack. It may also be proclaimed by appropriate authority in anticipation of an attack.

(2) *Civil Disturbance.* Any riot, act of violence, insurrection, unlawful obstruction or assemblage, or other disorder, prejudicial to public law and order within the 50 States, District of Columbia, Commonwealth of Puerto Rico, US possessions and territories, or any political subdivision thereof. The term “civil disturbance” includes all domestic conditions requiring use of Federal Armed Forces pursuant to the provisions of chapter 15 of title 10, United States Code.

(3) *Natural Disaster.* All domestic emergencies except those created as a result of enemy attack or civil disturbances. (The term “natural disaster” includes emergencies resulting from acts of nature and other disasters such as those created by the loss of control of radioactive or other hazardous materials, including gases and exotic fuels.)

(4) *Major Disaster.* Any flood, hurricane, or other catastrophe which, in the determination of the President, is or threatens to be of sufficient severity and magnitude to warrant disaster assistance by the Federal Government to supplement the efforts and available resources of State and local governments in alleviating the damage, hardships, or suffering.

b. Civil Defense. Civil defense is defined as, “All those activities and measures designated or undertaken to: (i) minimize the effects upon the civilian population caused, or which would be caused, by an enemy attack upon the United States; (ii) deal

with the immediate emergency conditions which would be created by any such attack; and (iii) effect emergency repairs to, or the emergency restoration of, vital utilities and facilities destroyed or damaged by any such attack.” AR 500-70 states that civil defense is the “planned and organized action aimed at the protection of life and property and the maintenance or restoration of essential services and facilities in war-caused emergencies.” Employment of DOD military resources to assist civil authorities in controlling civil disturbances is normally by presidential directive authorizing the Secretary of Defense to restore law and order in a certain locality. There are numerous plans which require support from DOD which will not be examined in detail but which require identification.

(1) *Postal Augmentation Plan.* This plan pertains to the DOD rendering assistance to the United States Postal Service (USPS) to safeguard, process, and deliver the US mail when ordered by the President. DOD guidance is contained in DOD Directive 5030.50.

(2) *The Emergency Animal Disease Eradication Plan.* This plan covers DOD assistance to the Department of Agriculture in the Emergency Animal Disease Eradication Program to swiftly and effectively eradicate animal and poultry disease outbreaks resulting from the accidental or intentional introduction of exotic foreign diseases.

(3) *Oil and Hazardous Substance Pollution Prevention and Contingency Programs* This program, established by DOD Directive 5030.41, implements the National Oil and Hazardous Pollution Contingency Plan and the Environmental Protection Agency (EPA) regulations on pollution prevention.

(4) *The National Search and Rescue Plan.* This plan pertains to the cooperative efforts by Federal, State, and local governmental and volunteer organizations in the conduct of search and rescue operations (SAR).

(5) *Other Emergency Plans.*

(a) In addition to the emergency plans listed above, several other emergency plans may be developed by major military commands and installations in support of other Federal agencies and/or State and local governments. Some of these plans are:

1 Support of Aircraft Piracy Emergencies.

Army support for this type of emergency is provided in accordance with AR 500-1.

2 Support of Fire Suppression Operations for Combating Forest and Grassland Fires in Continental United States (CONUS). This plan is based on a memorandum of understanding between DOD and the Departments of Agriculture and the Interior. This type support is furnished under the provisions of DOD Directive 3025.1, the Disaster Relief Act of 1974 (Public Law (PL) 93-288), and Executive Order 11775, 11 July 1974.

(b) In oversea areas, an important plan in which DOD supports the State Department is the Protection and Evacuation of US Citizens and Certain Designated Aliens in Danger Areas Abroad (short title, the Noncombatant Evacuation). The responsibilities for planning for operations of this type by the DA Staff and major oversea commanders are stated in AR 525-12, which implements DOD Directive 5100.51.

13-2. DOD Policy

a. Primary responsibility for alleviating effects of disasters or other domestic emergencies rests with individuals, families, private industry, local and State governments, the American National Red Cross, and Federal civil agencies having special statutory responsibilities. When the extent of the emergency is beyond the capabilities of the private sector, local, State, and Federal Government agencies to alleviate, emergency, military resources may be called upon to provide humanitarian relief.

b. It is DOD policy to provide military assistance to civil authorities in domestic emergencies in the United States, its territories, and possessions. When assistance is requested or directed in accordance with public laws, executive orders, and DOD directives, military assistance to civil authorities is undertaken only within prescribed authority except when:

(1) Humanitarian factors compel immediate action to prevent starvation, extreme suffering, and property loss.

(2) Local resources available to State and municipal authorities are clearly inadequate to cope with the situation.

c. Policies and procedures governing employment of military forces in support of civil authori-

ties differ, depending on the type of domestic emergency. In general, it is DOD policy that the military departments:

(1) Be prepared to furnish assistance to civil authorities for a limited period in domestic emergencies, utilizing resources not required in the execution of their essential military missions and, in the case of a civil defense emergency, resources not required in self-survival operations.

(2) Be prepared to maintain or support the reestablishment of law and order and protection of life and property in the event civil control or leadership is destroyed or overwhelmed. This military control will be withdrawn when civil control is reestablished.

(3) Develop plans or procedures at appropriate echelons of command for emergency employment of their resources to assist civil authorities in domestic emergencies.

d. Initially, assistance to civil authorities in domestic emergencies is provided by the military service having available resources nearest the afflicted area. The commander providing initial assistance during a natural disaster may be relieved, or his force augmented by other military commanders, within the affected area to the extent required, by mutual agreement between the senior service commanders concerned. In military support of civil defense operations, employment of multiservice forces engaged in the same operational area will be in accordance with procedures jointly established in area military support of civil defense plans.

e. A military commander, in making his resources available to civil authorities, is subject to no authority other than that of his superior in the military chain of command.

13-3. Responsibilities

a. The primary responsibility for coordinating both the planning and provision of military assistance to civil authorities in domestic emergency is assigned to the Department of the Army (DA). The Departments of the Navy and the Air Force render such assistance to DA consistent with the requirements of their primary missions.

b. The Secretary of the Army is the executive agent for DOD for planning, deployment, and employment of military resources to control civil disturbances, both inside and outside CONUS.

(1) The Secretary of the Army (or his designee) provides policy and direction to all military departments, the Joint Chiefs of Staff (JCS), the commanders of unified and specified commands con-

cerned, and all defense agencies for use of their military resources, including Reserve components, in civil disturbance operations. As executive agent, the Secretary of the Army accomplishes the necessary coordination, reporting, and procedural functions to develop, review, and implement civil disturbance plans and conduct operations.

(2) DA provides military support in domestic emergencies within CONUS when civil authorities cannot operate without this support.

(3) The Corps of Engineers:

(a) Division and District Engineers provide direct assistance to civil authorities in flood fighting, flood rescue work, and the repair or restoration of flood control works as authorized by PL 84-99.

(b) To mitigate results of disasters, direct coordination on disaster matters is exercised by the Division and District Engineer Offices with CONUS Army headquarters and with FEMA regional offices.

(4) US Army Information Systems Command (USAISC) provides commercial circuit leasing actions; specialized communications support to designated FEMA field teams and Army task forces; and operates fixed (nontactical) communications facilities at the US Army Forces Command (FORSCOM) and US Army Training and Doctrine Command (TRADOC) installations.

(5) Other major Army commands (MACOM) provide forces and resources to assist in alleviating the effects of disasters or other domestic emergencies consistent with assigned defense priorities.

(6) Army National Guard forces, not in active Federal service, remain under control of the State Governor and are included in the local resources available to civil authorities. Federally owned National Guard equipment may accompany a unit when ordered by a governor to assist civil agencies in domestic emergencies.

c. The JCS is responsible for maintaining a strategic reserve for worldwide employment and contingency operations. They establish procedures for transfer of military resources assigned to unified/specified commands to military departments or other unified commands for civil disturbance operations inside and outside CONUS. The JCS issues directives to unified/specified commands for employment of military resources for civil disturbances in areas outside CONUS.

d. The Secretaries of the Navy and the Air Force coordinate with and assist the Secretary of the Army in planning and furnishing support to civil authorities in domestic emergency operations. The support which they provide must be consistent with defense priorities.

(1) The Secretary of the Navy will order to active duty members of the Naval Reserve and Marine Corps Reserve if required for utilization. He also makes available to the Secretary of the Air Force available airlift resources.

(2) The Secretary of the Air Force designates elements of the Air National Guard to be called to Federal active service and orders members of the Air Force Reserve to active duty. In addition, he provides airlift and other required air support for civil disturbance operations. He also acts for the DOD executive agent as coordinating authority for DOD military and commercial airlift resources.

e. Commanders of unified commands outside of CONUS plan for and conduct civil disturbance operations within assigned areas of responsibility. They must organize, train, support, and maintain in readiness forces for these civil disturbance operations, consistent with defense priorities. If needed, they request additional forces from JCS and DOD executive agents.

f. Other Federal and civilian agencies:

(1) The Federal Emergency Management Agency (FEMA) is responsible for directing and coordinating Federal assistance in major disasters. Federal disaster relief operations are directed through the Administrator, FEMA regions, and a designated Federal coordinating officer (FCO).

(2) The Boise Interagency Fire Center (BIFC), under control of the Departments of Agriculture and the Interior, coordinate operations in forest and grassland fire emergencies.

(3) The General Services Administration (GSA) provides leasing action for Federal Telecommunications Services (FTS) and facsimile machines in disaster areas for use in communications with FEMA regional headquarters.

(4) The American National Red Cross, operating under a charter from Congress, is the official volunteer disaster relief agency of the American people. While Federal agencies deal primarily with State and local governments, the Red Cross plays a vital role in disasters by providing grants and other types of assistance to individuals and families to cover their emergency needs.

(5) The Salvation Army, Mennonite Disaster Service, and other relief or disaster assistance organizations, although not established by Federal law, cooperate and participate in disaster relief operations within their capabilities.

(6) The Environmental Protection Agency (EPA) provides for the coordination of Federal response to control a spill of oil or other hazardous substances on inland US waters.

(7) The US Coast Guard, a Department of Transportation agency, provides assistance to civil authorities in the protection of life and property in maritime disasters. The US Coast Guard:

(a) Exercises broad statutory authority for rendering aid to persons and protecting and saving property when Coast Guard facilities and personnel are available and can be used.

(b) Furnishes the onscene coordinator to supervise operations in the event of a spill of oil or other hazardous substance in coastal and contiguous zone waters, the high seas, and the Great Lakes, ports, and harbors.

(c) Coordinates, through district Rescue Coordination Centers (RCC), SAR operations in the maritime region.

13-4. Concept of Support

a. Support may be provided in several forms; i.e., commitment of resources (supplies and equipment) under the control of CONUS Army headquarters; arranging for the direct shipment of supplies and equipment from the US Army Materiel Command (AMC), Defense Logistics Agency (DLA), and GSA activities and/or other sources not under control of CONUS Army headquarters to a disaster area; and coordinating the logistical support of committed forces as necessary.

b. Military support to civil authorities is on a minimum essential basis and is terminated at the earliest practicable time.

c. Current logistics policies and directives apply with respect to supplies and equipment committed to disaster relief activities. Additionally, chapter 3, AR 500-60, will be followed without exception.

d. Military resources committed in support of an emergency plan are under the operational control of the designated disaster control officer.

e. Materiel support:

(1) Disaster area supplies and equipment are preferably obtained from the appropriate inventory manager. Items may be drawn from the nearest depot, station stocks, or withdrawn from active duty troops.

(2) Military resources for disaster relief include equipment and supplies of all DOD agencies.

(3) Military supplies and equipment are not set aside for use in connection with disaster relief activities.

(4) All requests for supplies and equipment in support of disaster relief are identified with a specific project code provided by AMC through appropriate CONUS Army headquarters. All requests/requisitions will use priority designator (PD) "03"

unless otherwise directed by responsible CONUS Army headquarters.

f. Plans are made locally for the return of supplies and equipment loaned to task force units or civil authorities. Basic to this plan is an adequate hand-receipt system to provide an audit trail for loaned equipment. This audit trail is essential to fix responsibility, especially in the case of loss or damage of equipment.

13-5. Logistics Support for Troops Committed to Emergency Operations

a. The plans for support of emergency operations, like those for combat operations, must prescribe how the military forces being employed are to be supported and who is responsible for providing this support. Each plan should include an Administration and Logistics paragraph or separate annexes, as appropriate, describing how the employed forces will be supported.

b. In developing plans for emergency operations, the following general guidance for logistics support of employed military forces must be considered:

(1) Forces deploying to disaster areas are equipped at home station with accompanying supplies to perform their assigned support mission and to be self-sustaining to the maximum extent possible.

(2) Logistics support to committed forces is normally provided by the installation assigned support responsibility for the particular area by AR 5-9 (with FORSCOM/TRADOC Supplements). When a Disaster Control Element (DCE) is established, logistics support is provided by the installation providing the DCE.

(3) Unless directed otherwise, supply units will deploy with only mission-essential Table of Organization and Equipment (TOE)/Modification Table of Organization and Equipment (MTOE)/Tables of Distribution and Allowances (TDA) and individual equipment. Three days of class I (operational rations (MRE)) will accompany units. Only the minimum necessary quantities of classes II, III, VII, VIII, and IX will be deployed with the troops. Special tools, supplies, and equipment (such as special protection devices) of unusually large quantities required for use in an emergency should be identified in each plan.

(4) Services:

(a) *Billeting.* Every effort will be made to billet forces in suitable indoor facilities under the control of military services (armories, training centers, etc.) or those of other Federal agencies. If

indoor facilities are not available, the troops must be prepared and equipped to bivouac under field conditions in areas under US Government control. When US Government-controlled facilities are not available or inadequate, requests are made for use of State or locally owned facilities or for contracting of facilities from other sources.

(b) *Food Service.* As soon as possible after units arrive in the emergency area, supporting commanders will provide T Rations and "B" rations with "A" ration supplements available. Soldiers should be fed at a central location when possible. Messes operate around the clock, as necessary, to support the shifts required to accomplish emergency tasks. For isolated personnel who cannot be fed at a central facility, box lunches or operational rations will be provided or food from the central facility will be transported to them. Necessary refrigeration for perishable subsistence is provided by the supporting installation commander by issuing suitable equipment or by contracting arrangements for commercial equipment.

(c) *Laundry Service.* Laundry service at Government expense is provided at the earliest possible date to military forces when deployed away from their home stations. When possible, this service will be provided by Government fixed or mobile laundry facilities. If suitable Government facilities are not available, the supporting commander can make contractual arrangements to provide the service by commercial facilities. In either case, processing time should not exceed 48 hours. Cost for this service is charged to OMA funds. Each military service supports the costs for laundry service provided its deployed personnel by either a military facility or a commercial facility.

(d) *Bath Service.* Bath service is provided by the nearest military installation, by mobile bath units or by making arrangements for use of local facilities (schools, armories, recreational facilities, etc.).

(e) *Medical Service.* Medical service is provided by organic TOE/MTOE/TDA/Modification Tables of Distribution and Allowances (MTDA) medical personnel/organizations. Backup medical support and hospitalization is provided by the supporting installation commander from resources under his control, or through arrangements with other military services/US Government agencies or other sources, as prescribed by The Surgeon General (TSG) for medical support in CONUS.

(f) *Mortuary Service.* Mortuary services for deceased members are the responsibility of each service. Remains of deceased active duty Army personnel are processed as prescribed in AR600-10

and AR 638-40. Remains of deceased personnel of the US Navy, US Air Force, or US Marine Corps are processed as prescribed by their respective regulations.

(g) *Contracting Service.* The deployed force must have the capability to award, administer and close out contracts.

(5) Upon order, military forces and accompanying equipment will move from home station to affected emergency areas by the most expeditious mode of transportation. Military transportation is used to the fullest extent in moving to and from disaster areas. Requirements in excess of unit organic capabilities are the responsibility of the installation deploying the force.

(a) For air transportation, the commander of the installation from which the forces are deployed is responsible for providing necessary ground transportation from the home station to the departure airfield and necessary Departure Airfield Control Groups. The support installation commander receiving deploying troops must provide necessary arrival airfield control groups and ground transportation from the arrival airfield to the final destination.

(b) Transportation within the emergency area is the responsibility of the task force commander. Additional transportation required is requested from the supporting installation commander.

(6) Support beyond the organic capabilities of the unit is provided by the supporting installation commander through the use of mobile direct support (DS)/general support (GS) teams or through arrangements with US Army Reserve (USAR)/US National Guard (USNG) maintenance support activities, or other installation commanders. Assistance by logistics assistance representatives associated with the AMC Logistics Assistance Program can be requested as needed.

(7) Engineering support for the acquisition, lease, and disposal of real estate in the emergency area is obtained from the appropriate division/district engineer.

13-6. Reimbursable Expenses Incident to Emergency Operations

a. DOD components can request reimbursement from the appropriate responsible agencies for support furnished these agencies as the result of presidential declared disasters or emergencies and certain other emergencies when military support was requested by the responsible civil authorities.

b. The commander of the Army installation furnishing the support prepares all billings on Standard Form 1080 and sends that, together with all supporting documents, through channels to the Army Comptroller for the necessary collection action, as indicated in the appropriate emergency plan.

c. Military expenses incident to disaster relief participation for which reimbursement may be requested includes:

(1) Pay of additional civilian personnel temporarily hired especially for the disaster relief operation without regard to the Civil Service Laws and the Classification Act of 1923, as amended.

(2) Overtime pay of civilian personnel.

(3) Travel and per diem expenses (military and civilian).

(4) Cost of consumable items of supply requisitioned for issue to civilian disaster refugees.

(5) Transportation of personnel, supplies, and equipment.

(6) Port (air, ocean, inland-waterway) loading, offloading, and handling costs.

(7) Cost of repairing or reconditioning nonconsumable items returned.

(8) Cost of supplies and equipment furnished and not returned.

(9) Cost of repair parts used to repair end items located at the disaster area (excluding depot or field maintenance on time-compliance basis).

(10) Cost of packing and crating supplies and equipment.

(11) Cost of petroleum, oil, and other lubricants (including aviation petroleum, oils, and lubricants (POL)).

(12) The cost as determined by adjustment documents of supplies and equipment lost, destroyed, or damaged beyond economical repair, except aircraft, motor vehicles, and/or watercraft.

13-7. Reports

Each emergency plan prescribes the reports and reporting procedures for that plan. Each report is normally identified and becomes an appendix to a report's annex to the particular plan. These reports do not replace any existing reporting requirements. Some of the reports common to all plans are:

a. Logistics Status Reports (format at appendix F).

b. Personnel Status Report.

c. Report of Operation Costs (format at appendix E).

d. Movement Requirements Report (format at appendix G).

e. Unit Movement Report (format at appendix H).

f. Situation Report.

Section II. CIVIL DEFENSE

13-8. Authority and Objectives

By law (50 USC appendix 2251 et seq.) civil defense is a joint responsibility of Federal, State, and local governments. The national civil defense program is an integral part of national security. Military support to civil authorities in civil defense operations is an emergency task within the mission of all defense agencies and Federal active duty and Reserve component units of the military services. Military assistance is complementary to, but not a substitute for, civilian participation in civil defense. The basic objectives of the program are to:

a. Protect life and property.

b. Sustain survivors and repair essential utilities.

c. Achieve emergency operational capability.

13-9. Planning

a. A Military Support of Civil Defense Annex is included in the basic plans for defense of the United States, its territories, and possessions. Planning for military support of civil defense is directed toward the most dangerous contingency of a nuclear attack with minimum warning under conditions favorable to the attacker. Those forces which could be temporarily furnished to assist civil authorities in a civil defense emergency, together with probable availability, are designated in area support plans. Provisions are included in the plans for their withdrawal should it be necessary to employ these forces in the defense of the United States or when they are no longer required for civil defense missions.

b. All military forces (active and Reserve), other than those deployed outside the 50 States and those in the District of Columbia and the territo-

ries and possessions of the United States, are considered potentially available to provide temporary emergency support to civil authorities during certain stages of civil defense operations. The availability of forces to provide this support will vary according to the military requirement for the conduct of essential combat, combat support, or self-survival operations. Within CONUS, each military department provides the CONUS Army commanders with periodic listings of all its military forces and components located within each CONUS Army area in order of priority of probable availability for support of civil defense operations. The priority is based on the military missions of the forces reported, their location, and their capabilities to perform civil defense assistance tasks. Forces are listed by priority as:

(1) Priority I—Those forces that have a high probability of availability for civil defense support in the immediate emergency period.

(2) Priority II—Those forces that have a lower probability of availability to support civil defense in a postattack period.

(3) Priority III—Those forces least likely to be available for civil defense support operations because of the high priority of their combat and combat support missions.

13-10. Actions in Event of an Attack

If there is a nuclear attack upon the United States, military forces have an initial priority commitment of mounting offensive and defensive actions and of assisting civil authorities in danger control measures and assessing damage and danger areas in CONUS. Where extensive damage is found, the priorities assigned to civil support are evaluated against planned military combat operations requirements. Measures to insure continuity of operations, troop survival, and rehabilitation of essential military bases take precedence over military support of civil defense. Under nuclear attack conditions, military forces must be prepared to employ all resources not engaged in or directly supporting essential operations to assist civil authorities to:

- a. Restore order and civil control.
- b. Return essential facilities to operation.
- c. Prevent unnecessary loss of life and damage to property.
- d. Alleviate human suffering.
- d. Take other emergency actions as directed to insure national survival and a capability on the part of the Nation to achieve national objectives.

13-11. Responsibilities

a. The DA responsibilities are exercised through the Commander, FORSCOM, the CONUS Army commanders, and the State military headquarters or State military subarea headquarters organized for this purpose.

b. The Commander, FORSCOM, is responsible within the 48 contiguous States for establishing State military headquarters to plan for and conduct operations in support of civil defense. He is responsible for the readiness of all Army forces in CONUS to conduct emergency civil defense operations and the training of Army personnel in the basic functions of civil defense. The direction and control of resources used for civil defense, including those resources made available by other military departments and defense agencies, is exercised by the Commander, FORSCOM. He also coordinates military defense plans with civil defense plans.

c. Commanders of other MACOMs and heads of DA General and Special Staff Agencies support the requests of the Commander, FORSCOM and CONUS Army commanders in execution of their civil defense responsibilities. The Commander, USAISC is charged with operating and maintaining designated communications systems including warning and emergency systems. Overall monitoring of military support of civil defense matters within the DA Staff is exercised by the Deputy Chief of Staff for Operations and Plans (DCSOPS). Installation commanders furnish immediate supplementary support to local civil authorities where civilian control is no longer effective.

13-12. Logistics Support

a. Army contingency plans for operation in civil defense role should provide for priorities of support planning and training assistance, maximum decentralization, and use of military resources when needed to complement use of civil resources. Figure 13-1 shows the categories of assistance of civil defense.

b. Military resources used in civil defense operations remain under military control, except for those transferred directly to civil defense authorities. Logistics support of civil defense operations by DA is accomplished with minimum diversion of Army stocks. Active Army and USAR civil affairs units and individuals are given priority consideration for use in civil defense support operations because of their specialized training in functional areas of governmental operations.

FM 701-58

LOGISTICS TASKS	SUPPORTING UNITS
Restoration of facilities and utilities e.g. power, fuel water, communications	Engineer, Signal, Transportation
Emergency clearance of debris	Engineer, Transportation
Fire protection	Engineer
Radiation monitoring and decontamination	Engineer
Rescue evacuation and treatment of casualties	Medical, Transportation (Air and Ground)
Recovery and disposition of deceased	Graves Registration
Movement control	Transportation
Issuance of food, essential supplies, and materiel	General Support and Direct Support Supply Units
Mass feeding	Mess and Bakery Teams
Damage assessment	Engineer
Emergency communications	Signal
Explosive ordnance disposal	Ordnance
Physical security	Provost Marshal Office

FIGURE 13-1. LOGISTICS TASKS AND UNITS SUPPORTING CIVIL DEFENSE.

Figure 13-1. Logistics tasks and units supporting civil defense.

Section III. CIVIL DISTURBANCES

13-13. Responsibilities

a. State and Local Government Roles. The protection of life and property and the maintenance of public order are primarily the responsibility of

State and local governments. Local and State police are normally capable of fulfilling this responsibility. When emergency conditions exceed their capabilities, the governor of a State can commit the State National Guard. Generally, Fed-

eral Armed Forces are employed after State and local civil authorities have utilized all of their own forces which are reasonably available for use, and are unable to control the situation, when the situation is beyond the capabilities of State or local civil authorities, or when the State and local civil authorities will not take appropriate action.

b. DA Role.

(1) The Secretary of the Army is the designated executive agent for DOD in all matters pertaining to the planning for, and the deployment and employment of military resources in the event of civil disturbances. This includes calling to active Federal service units of the Army National Guard to carry out the provisions of the Presidential Executive order or other appropriate authorities.

(2) The DOD executive agent has been delegated the authority to exercise, through the Chief of Staff, US Army, the direction of those forces assigned or committed to him by the military departments.

(3) At the DA level, the Director of Military Support, Office of the DCSOPS, has General Staff responsibility for civil disturbances outside installations. For disorders occurring totally within an installation, the responsibility is that of the Deputy Chief of Staff for Personnel (DCSPER).

(4) The DOD has designated the Secretary of the Army as executive agent for providing assistance to the Federal Bureau of Investigation (FBI) in combatting terrorism in the 50 United States, District of Columbia, Commonwealth of Puerto Rico, and US possessions and territories. Terrorist incidents do not include Aircraft Piracy Emergencies. In such instances, military resources may be used, as in civil disturbances provided for in AR 500-50, to protect life or Federal property or prevent disruption of Federal functions upon request of the Director, FBI, or senior FBI official present at the scene of a terrorist incident.

c. Role of Other Military Services. The other military services are responsible for providing military resources as required by the DOD executive agent and consistent with defense priorities.

13-14. Employment of Federal Armed Forces

In addition to the provisions of the Constitution and other basic legal principles, there are numerous statutes authorizing the employment of Federal Armed Forces, in cases of violence or other specific purposes, within any State and within the territories of the United States. The possibility of employment under many of these provisions is considered remote, and only those instances where

employment is most likely are treated here. Additional constitutional and statutory provisions for the employment of Federal Armed Forces to include the prerequisites for employment are discussed in AR 500-50 and FM 19-15.

13-15. Protection of Federal Property

a. Protection of Federal property or functions by intervention with Federal Armed Forces is an accepted principle of our Government. This form of intervention is warranted only where the need for protection exists and the local civil authorities cannot or will not give adequate protection. This right is exercised by executive authority and extends to all Federal property and functions.

b. The Manual for Courts Martial, United States, 1969 is the commander's authority to maintain law and order on a military installation. The commander may take such actions as are reasonably necessary and lawful, including ejection from, or denial of access to, the installation or its activities (18 USC 1382 and AR 600-40). If appropriate, such individuals may also be apprehended or restrained. Basic guidance for the commander is found in AR 210-10 and DA Pam 27-164. For prosecution of minor offenses committed on military reservations before a United States Magistrate, see chapter 6, AR 27-40.

c. When a civil disturbance presents a threat to persons, property, or functions on a type A, B, or C installation/activity (as defined in AR 5-3) which is beyond the combined protection capability of the installation commander and civil law enforcement resources, FORSCOM will be requested to take appropriate action.

d. When the commander of a type D installation/activity under the jurisdiction of a MACOM direct supervision or of a HQDA Staff agency is reasonably certain that a civil disturbance presents a threat to persons, property, or functions on his installation/activity which is beyond the combined protection capability of his own and civil law enforcement resources and those of the appropriate MACOM, the major commander concerned requests support directly from Commander, FORSCOM.

e. Upon receiving requests for assistance, the Commander, FORSCOM has authority to employ augmentation forces as required to reinforce the internal security forces of type D installations/activities. When such action is taken, the Commander, FORSCOM notifies DA. If, in the judgment of the major commander(s) involved there may be jurisdictional or sensitive community relations implications connected with the use of Feder-

al troops to protect a type A, B, C, or D installation/activity, no action is taken until the appropriate major commander requests and receives specific instructions through established command channels.

f. When an installation commander learns that a need for the protection of other Federal property of functions (except type A, B, C, and D installations/activities) exists, he notifies DA through command channels.

13-16. Emergency Employment

This may be accomplished in cases of sudden and unexpected invasion or civil disturbance, including civil disturbances incident to earthquake, fire, flood, or other public calamity endangering life or Federal property or disrupting Federal functions or the normal processes of Government, or other equivalent emergency so imminent as to make it dangerous to await instructions from the DA. It is unlikely that action under this authority would be justified without prior DA approval while communications facilities are operating. Such action, without prior authorization, of necessity must be prompt and vigorous. However, actions should be designed for the preservation of law and order and the protection of life and property until such time as instructions from higher authority have been received. In the event of civil disturbances requiring action before the receipt of instructions, the officer taking such action will report his action immediately, and the circumstances requiring it, to the Director of Military Support, DCSOPS, DA, by the most expeditious means of communication available, in order that appropriate instructions can be issued at the earliest possible time.

13-17. Legal Restrictions

a. The "Posse Comitatus Act" (18 USC 1385) provides that whoever, except in cases and under circumstances expressly authorized by the Constitution or act of Congress, willfully uses any part of the Army or Air Forces as a posse comitatus or otherwise to execute the laws shall be fined not more than \$10,000 or imprisoned not more than 2 years or both.

b. Military forces acting in civil disturbances under the provisions of 10 USC 331-333 in those instances cited in paragraph 19-17d(1)-(3) of the critical code are not in violation of the Posse Comitatus Act; nor does the prohibition extend to the employment of Federal functions and property, or from acting in an emergency as described in paragraph 19-17f of the cited code.

c. It should be noted that the Posse Comitatus Act does not prohibit measures of military assist-

ance amounting to "protection" as opposed to "law enforcement." Thus, it does not prohibit the use of Army bomb disposal experts in deactivating and destroying explosives found in civilian communities; nor does it prohibit Army medical personnel from rendering medical care to persons injured in a civilian calamity. Likewise, this law does not prohibit a member of the Army, acting in his private capacity, from making a citizen's arrest in accordance with the law of the State where he is located.

d. Few States have laws similar to the Posse Comitatus Act. The military forces of a State, its National Guard, exist for the purpose of executing the laws of the State. However, State laws usually provide specifically who has authority to call on the National Guard (when not in Federal service) for assistance and describe the circumstances when assistance can be rendered. The Posse Comitatus Act does not apply in cases where a State military force is called on for assistance by appropriate State officials. It would, however, become applicable to such force if it had been called into Federal service.

13-18. Logistics Support

a. Commander, FORSCOM is responsible for logistics support of all active military ground forces in the objective area through the home station Installation Support Office (ISO) for unit accompanying supplies or through the Base Support Installation (BSI) in each objective area for resupply.

b. Commander, AMC is responsible for wholesale logistics support of ground forces based upon requests from BSI and ISO through use of expedited special procedures and pre-positioned depot stocks maintained in operational readiness condition.

c. Director, DLA is responsible for wholesale supply support based upon requests from BSI and ISO.

13-19. Use of DA Resources

a. Army forces participate in civil disturbance operations at the request of State and local civil authorities. The use of Army forces for civil disturbance operations should end as soon as normal civilian control is reestablished.

b. US Army resources are classed in three groups as follows:

(1) *Group One.* Personnel, arms, ammunition, tank-automotive equipment, and aircraft.

(2) *Group Two.* Riot control agents, concertina wire, and other like military equipment to be employed in control of civil disturbances which is not included in group one.

(3) *Group Three.* Firefighting resources (including operating personnel); equipment of a protective nature (such as masks, helmets, body armor vests), and other equipment not included in groups one and two (such as clothing, communications equipment, searchlights); and the use of Army facilities.

c. Repair parts and POL items are classified according to the group of equipment for which the parts or POL are intended.

d. Requests for group one and two resources require personal approval by the DA executive

agent or the Under Secretary of the Army when designated. A task force commander may also be designated to approve group two resources. Group three resources can be approved in the same manner as group one by CONUS Army commanders and the Commander in Chief (CINC) of unified commands outside CONUS.

e. Army equipment can be made available to civil authorities by sales of surplus or by loans within the procedures described in chapter 4, AR 500-50.

Section IV. DISASTER RELIEF

13-20. General

a. As in civil defense, disaster relief is primarily the responsibility of civil governments. Military assistance to civil authorities in natural disasters may be provided by DOD when requested or directed in accordance with the Disaster Relief Act of 1974 (42 USC 5121-5202). US Army participation is in accordance with AR 500-60.

b. Normally, military support to disaster relief will be at the request of the Administrator, FEMA, who is responsible for coordinating the activities of all Federal agencies in rendering support to State and local governments during major disasters. However, when the disaster is of such imminent seriousness that delay in awaiting instructions is unwarranted, a military commander should take such action as may be required and justified to save human life, prevent immediate human suffering, or mitigate major property damage or destruction. The Secretary of the Army is DOD executive agent for disaster relief activities within the United States. This includes responsibility for effective utilization, coordination, and control of resources made available by other components of DOD. The Commander, FORSCOM, is responsible for Army support activities within CONUS to include coordination with other services or defense agencies or both. Commanders of all MACOMs support disaster relief operations with military resources as required by the Commander, FORSCOM. Installations, activities, and agencies support disaster relief efforts within their capabilities. The Chief of Engineers provides disaster assistance to FEMA as a function under its Civil Works Program.

13-21. Military Participation

a. Use of military resources and other military participation in disaster relief operations will be the minimum essential. Participation is terminated at the earliest practicable time. Unless formally

directed by the FCO, all support will terminate within 3 months, and rarely could support be justified for that long under the "minimum essential basis" rule. Military assistance in rehabilitation following a disaster is authorized only when directed by FEMA, or in support of emergency operations conducted by the Corps of Engineers as authorized by law.

b. Disaster relief support in friendly foreign areas is conducted by the commander, unified command, in response to requests from the State Department. In Alaska, Hawaii, and US territories, the appropriate unified commander is responsible for the conduct of disaster relief operations. In occupied areas, disaster relief operations are the responsibility of the military commander until such time as directives or agreements promulgated by the US Government prescribe otherwise.

c. The American National Red Cross, by its charter, is organized to undertake activities for the relief of persons suffering from disaster. In instances not involving FEMA, the Red Cross can be expected to request Army assistance when local resources are inadequate. The Red Cross will be furnished, unless resources are not available, supplies, equipment, or services on loan or by purchase. Reimbursement will be made by the Army Comptroller upon receipt of Standard Form 1080 from the Army commander concerned.

13-22. Planning

a. DOD components have been directed to develop appropriate contingency plans for major disaster assistance operations and insure that these plans are coordinated with appropriate Federal, State, and local civil authorities and other DOD components. MACOMs, CONUS armies, and installations formulate plans to conduct disaster relief operations in their areas of responsibility.

b. Planning for military support of disaster relief should consider all aspects of logistics. The types of support required will vary according to type and intensity of damage, local facilities, density of population, and warning received. Logistics support most likely to be requested includes:

- (1) Evacuation, housing, and feeding.
- (2) Care of injured.
- (3) Supply of clothing, food, and medical supplies.
- (4) Water purification.
- (5) Emergency communications support.
- (6) Physical security.

c. Army-owned supplies and equipment not immediately required in the execution of a primary mission may be made available for use in disaster relief operations. Stocks of the least serviceable class will be used. Military supplies and equipment will not be set aside for disaster relief use. Surplus supplies and equipment may be donated to local and State governments. Stocks may be issued on loan but must be returned at the end of the disaster and costs for repair, rehabilitation, or modification charged to FEMA for those items requested by that activity. Army stock fund-owned items may be issued with reimbursement requested.

13-23. Funding

a. Disaster relief participation is an unprogrammed requirement of DA. The Army budget does not include allocation for disaster relief operations nor does DA or its subordinate commands retain fund reserves for this purpose. Such operations are undertaken on the premise that costs other than normal operating expenses will be reimbursed by the agencies outside DOD which request military participation in disaster relief operations. Requests for reimbursement for these expenses are submitted to FEMA within 90 days of completion of assistance for each specific disaster. Funding and accounting procedures are described in chapter 4, AR 500-60.

b. Oversea commanders are authorized to commit command funds up to \$25,000 to meet a request for disaster assistance from Department of State or the chief of the diplomatic mission of the country involved. If the costs exceed \$25,000, prior approval by the Assistant Secretary of Defense (International Security Affairs) is required. Oversea commanders are responsible for determining and recording reimbursable costs due from the requesting agency. Since these costs are financed as automatic reimbursements, the oversea command must promptly bill the responsible office requesting disaster relief assistance.

Section V. MILITARY SUPPORT OF OTHER EMERGENCIES

13-24. Army Participation in Other Emergencies

a. The Secretary of the Army has been designated DOD executive agent for all matters relating to military assistance in support of certain emergency operations. Among these are:

- (1) Support to the USPS (Postal Augmentation Plan).
- (2) Support of the Secretary of Agriculture for Emergency Animal Disease Eradication.
- (3) Military Assistance to Safety and Traffic (MAST).
- (4) Assistance to the Boise Interagency Fire Center for combating forest and grassland fires.

b. DA provides support as directed by DOD for other emergency situations, such as:

- (1) Assistance in oil and hazardous substance spills.
- (2) Search and rescue operations.
- (3) Assistance in the event of air piracy/airplane hijacking incidents.

c. The Chief of Diplomatic Mission or principal officer of the State Department has primary responsibility for the protection and evacuation of all US noncombatants, including dependents and certain designated aliens in danger areas abroad in time of emergency. The Secretary of State is responsible for preparing plans for the protection of all noncombatant US citizens and certain designated aliens abroad and provide for their evacuation to an area of greater safety (including evacuation to the United States when desirable and feasible); their protection and welfare in safe havens abroad; and their protection and welfare in their normal location. This responsibility includes integrating DOD plans into State Department plans for evacuating DOD noncombatants from West Germany but excludes responsibility for US citizens in West Berlin, Panama Canal Zone, and US Naval Base, Guantanamo. Responsibility for these latter is that of the Secretary of Defense.

(1) The Chiefs of Diplomatic Missions and principal officers prepare the plans for their areas of responsibility and implement them when required.

(2) Commanders of unified commands prepare plans for areas which are the responsibility of the Secretary of Defense. They also cooperate with the Chiefs of Diplomatic Missions and principal officers to carry out their planning responsibilities. When feasible, the commanders of unified commands assist in the evacuation or protection of those persons for whom the Secretary of State is responsible and assistance is requested. Normally, the principal military commander in an area must receive authorization from the JCS before using any of his forces or facilities in a foreign country for protection and evacuation purposes. However, where US citizens are in danger and communications with the JCS are cut off or cannot be established in time, the appropriate military commander, upon request of the principal diplomatic representative, provides such assistance as he deems

feasible. Where communications between the military commander and the diplomatic representative are disrupted, the military commander takes such action as is needed to protect US citizens.

(3) Military operations to assist the implementation of emergency and evacuation plans are conducted by the appropriate military commander. Where possible, he acts in coordination with the principal US diplomatic or consular representative.

(4) The military commander and the principal US State Department representative determine what military forces and equipment are necessary and appropriate. In making this determination, they consider the repercussions of Armed Forces versus those of unarmed forces with the risk of successfully accomplishing their missions.

APPENDIX A

SAMPLE FORMAT OF AMC LOGPLAN

REFERENCES:

- a. CINCLANT OPLAN (Number) (U).
- b. FORSCOM/USARLANT OPLAN (Number) (U).
- c. XVIII Airborne Corps OPLAN (Number) (U).
- d. AMC LP&P (U).
- e. x x x x.

A-1. () Situation.

a. General.

(1) This plan provides for the logistics support of FORSCOM/USARLANT OPLAN (Number) (ref b) and XVIII Airborne Corps OPLAN (Number) (ref c) x x x x x.

(2) Logistics Support Concept: (Include an outline summary of the overall course of the intended action.)

(3) x x x x x.

b. *Friendly Forces.* AMC LP&P applies except as modified herein: (In subparagraphs for each, give information of commands (JCS will not be listed under this paragraph but will be under paragraph ld (Assumptions) below, when appropriate) and agencies other than within the AMC which may directly affect the action of AMC subordinate elements or which support the implementation of the plan.)

(1) GSA.

(2) DLA.

(3) DA.

(4) x x x x.

c. *Assumptions.* (Insert assumptions as necessary to fill in gaps in the knowledge of what conditions are or probably will be. State assumptions as declarative sentences.)

A-2. () Mission.

(A clear concise statement of the mission and its purpose.) CDR, AMC plans and provides logistics support to x x x x.

A-3. () Tasks for AMC Staff Elements, Major Subordinate Commands, Installations, and Activities.

(Include a short lead-in statement, if necessary, for clarity.)

a. *Responsibilities.* AMC LP&P applies except as modified herein:

(List the task assigned to each AMC element. Each task should be a concise statement of a mission to be performed either in the planning, alert or execution phase of the plan by using the tasks enumerated in the AMC LP&P by reference.)

(1) *Deputy Chief of Staff for Readiness (AMCRE).*

(a) x x x.

(b) x x x.

(2) *Deputy Chief of Staff for Supply, Maintenance, and Transportation (AMCSM).*

(a) x x x.

(b) x x x.

(3) *Deputy Chief of Staff for Production (AMCPD).*

(a) x x x.

(b) x x x.

(4) *Deputy Chief of Staff for Personnel (AMCPE).*

(a) x x x.

(b) x x x.

(5) *Deputy Chief of Staff for Resource Management (AMCRM).*

(a) x x x.

(b) x x x.

(6) *Chief, AMC Logistics Systems Support Activity (LSSA).*

(a) x x x.

(b) x x x.

(7) *Chief, AMC Catalog Data Activity.*

(a) x x x.

(b) x x x.

(8) *CDR, Materiel Readiness Support Activity (MRSAs).*

(a) x x x.

(b) x x x.

(9) *AMC Major Subordinate Commands and Service Item Control Center (SICC).*

(a) x x x.

(b) x x x.

(10) *CDR, USA Depot System Command (DESCOM).*

(a) x x x.

(b) x x x.

(11) *Commanders, US Army Depots.*

(a) x x x.

(b) x x x.

(12) *Commander, Anniston Army Depot (ANAD).*

(a) Provide pre-positioned emergency supply package x x x.

(b) x x x.

(13) *Commander, USA Logistics Control Activity (USALCA).*

(a) x x x.

(b) x x x.

b. Coordinating Instructions (List those instructions applicable to the entire AMC or two or more elements of AMC which are necessary for the proper coordination of the LOGPLAN; i.e., the condition for executing the LOGPLAN, the terms pertaining to the timing of execution D-day or C-day etc.)

A-4. () Administration.

a. Actions and Reports. See annex X.

b. Security.

A-5. () Command and Signal.

a. Command.

b. Coordination and Control.

(1) x x x.

(2) x x x.

c. Signal.

(1) x x x.

(2) x x x.

Thompson
General

OFFICIAL:
WILLIAMSON
Deputy Chief of Staff for Readiness:

Annexes:

A—Force and Equipment Requirements Data

B—Supply Schedules

C—Supply Requirements Criteria

D—Distribution and Transportation

* E to L—NOT USED

M—TSG Medical Materiel

* N to W—NOT USED

X—OPLAN Planning and Execution Checklists

* Y—NOT USED

Z—Distribution

* When an annex is not used, place the index "not used" opposite the letter designation. Additional annexes may be inserted, using letters not listed above. Annexes may be published, distributed, and maintained separately, as appropriate.

APPENDIX B

CONTINGENCY OPERATIONS LOGISTICS CHECKLIST

This checklist is provided to assist logistics planners in preparing to meet the needs that could exist in a contingency operation. The checklist can be used by planners at any command level. It is not all inclusive as the peculiarities of each contingency cannot be identified.

B-1. References.

Is a listing of doctrinal, policy, and procedural publications, appropriate to the level at which the plan is prepared, provided to assist the implementer?

Are there any contingency plans that apply?

Are the maps necessary for understanding and implementing the plan listed?

B-2. Purpose.

Is there a concise statement of the purpose of the logistics support plan?

B-3. General.

Does this paragraph provide a summary of the requirements, taskings, and concept of operations that the logistics planning supports?

Are the objectives specified?

B-4. Assumptions.

Does this paragraph list the assumptions upon which the concept of operations and logistics support are based?

B-5. Responsibilities.

Are the responsibilities for support clearly stated for the following?

- Office of the Joint Chiefs of Staff
- US Readiness Command
- US Central Command
- US Southern Command
- Joint Deployment Agency
- Special Operations Forces
- Headquarters, Department of the Army
- US Army Materiel Command
- National Guard Bureau
- Office of the Chief of the Army Reserve

- Defense Security Assistance Agency
- Department of State/American Embassies
- Military Groups
- Offices of Defense Coordination
- Military Liaison Offices
- Defense Logistics Agency
- General Services Administration/Federal Supply Service
- US Army Troop Support Agency
- Army and Air Force Exchange Service
- US Army Health Services Command
- US Army Medical Materiel Management Agency
- Military Airlift Command
- Military Sealift Command
- Military Traffic Management Command
- US Army Forces Command
- Other major commands
- Unit commander providing command and control (task force, brigade, division)
- Unit or element providing logistics support (support battalion, support group, DISCOM)

B-6. Concept of Logistics Support.

Does this paragraph describe how supply, maintenance, transportation, and field service support will be provided?

Does it specify which logistics elements will provide the support? Are the forces provided adequate? Is there any excess capability?

Has the logistics planner developed the support to complement the tactical planning?

Have terrain and enemy intelligence been analyzed to determine the impact on logistics support?

Has the deployment flow been properly analyzed to determine time-phasing for introduction of logistics elements?

B-7. Supply.

a. General.

Is supply system and procedural guidance provided?

Is the flow of requisitions described?

Do automated systems of supported units and task organized CSS units have interface?

Is the flow of materiel described?

Is a project code required (OSD, JCS, DOD, DA)?

Is a temporary FAD upgrade required?

Are in-country DODAACs required (SSA, unit level)?

Are DSS/ALOC procedures described?

Are provisions made for contracting, local purchase, and COPARS support?

Are the stockage objectives by class of supply specified?

Is a known or estimated OST provided?

Will automated or nonautomated procedures be used?

Have the interservice support requirements been identified?

What support can/will be provided by the host nation, allies, or other services?

What support can/will be provided to the host nation, allied, or other services?

What intratheater support is required?

Are retrograde procedures for excess and un-serviceable items spelled out?

Is the control of aviation intensively managed items addressed?

Are provisions made for emergency resupply?

Have initial preplanned supply support and AMC emergency support packages been considered?

Is the communications transceiving capability provided and compatible with the automated systems being deployed?

Are changes to the DODAAC required, such as "ship-to" address?

Are some supply support activities required to be designated as ALOC or DSS?

Are procedures described for cancellation/diversion of materiel inprocess/intransit at the termination of the operation/exercise?

Are provisions made for logistics support of civilians and prisoners of war?

Is there covered storage in the area of operations to protect supplies from the elements? If not, are shipments packed for outdoor storage?

Are MHE requirements provided?

b. Class I.

Are the meal cycles described by phase?

Are fresh eggs, fruits, vegetables, meats, juices, UHT milk, and canned soft drink supplements to the MRE, T, and B ration meals considered?

Do local fresh fruits and vegetables meet US standards?

Have unitized operational rations been considered for ease of handling and accountability?

Are cash meal payment procedures established?

What method of distribution will be used (unit or supply point)?

Are bakery supplements to MRE, T, and B ration meals considered?

Are veterinary personnel adequate for the subsistence support requirements?

Are hospital rations addressed?

Are chill and freeze reefer requirements for unit dining facilities and the Class I DS/GS supply points addressed?

Is a ration cycle proposed?

Are water support requirements satisfied?

Are the sources of water fresh, brackish, or salty?

Is the source of water local systems, surface, or wells?

What type of water purification unit is required (Erdlator or ROWPU)?

Are chillers required?

What is the water planning factor in gallons/person/day?

Do water planning factors include consideration for NBC decontamination needs?

What are the treatment/storage/distribution/cooling requirements? Are they satisfied by deploying unit capability?

What are the well-drilling requirements? Are there any existing wells? What is the quality of water from existing wells?

Are potable ice considerations covered? What is requirement planning factor?

Have the medical planners provided for certification of ice as potable?

Will ice be provided by the engineers or will host nation provide?

Will mess kits and laundry line disposable utensils be used?

c. Class II.

Are requirements for individual clothing, CTA 50-900 items, and mission-essential consumables addressed?

Have provisions been made for replacement of damaged personal and chemical protective clothing, mask filter and personal decon kits?

Which self-service supply center listing will be used as the basis for Class II stockage?

How will the logistics support element replenish organizational clothing items and equipment and SSSC items?

Are there any items that required special consideration, such as:

Tentage, tentage repair kits?

Folding cots?

Insect bars with mosquito netting?

Banding materiel and tools?

Water purification chemicals, test kits?

Insect repellent, sun screen?

Field laundry/bath supplies, hospital laundry supplies?

Dining facility supplies, paper and plastic products?

Trash disposal supplies?

Vector control equipment and supplies?

Latrine chemicals/supplies?

Batteries?

Cold weather clothing, cold weather equipment?

d. Class III.

Are the requirements by location in gallons/day for each type product established?

Have JP4 requirements of medical units been considered?

Is the use of contractor-provided bulk fuel supply considered?

Are ordering/accountable officer requirements addressed?

Are existing pipeline distribution systems available? What are the pipeline capabilities? Is the distribution system hardened?

Are port facilities available?

If utilized are contractor provided fuel storage sites hardened?

Are remote refueling sites required? What capabilities?

Are interservice support billing and reimbursement procedures specified?

Are QAR responsibilities established?

Are POL quality surveillance procedures specified? Are required test kits on hand?

Are additives required for commercial fuels? Who will provide?

Are any unique package product requirements addressed?

Are industrial gasses addressed?

Are host nation capabilities evaluated and requested?

e. Class IV.

Are unique requirements for construction/security materials addressed?

Is in-country procurement considered?

Are prescribed loads to be deployed?

Do the nonengineer units have prescribed loads? Will they be deployed?

Will the use of pre-positioned materiel stocks be permitted?

f. Class V.

Is UBL deployment adequately addressed?

Is the logistics support structure prescribed?

Are training ammunition requirements addressed?

Are there special/unique requirements (flares/mines/demolition)?

Has a request for site approval and construction of ammunition storage facilities been included in engineer planning?

Have the storage, handling, shipping, security, and safety requirements been reviewed and addressed in the planning?

Are requirements identified by category of munition (conventional, missile, chemical, nuclear)?

Are sustaining rates of munitions addressed?

Are special permits needed/provided for?

g. Class VI.

Are the deploying personnel provided guidance on personal demand items?

Are sundry packs available?

Is a TFE considered?

If TFE support is required:

Has Headquarters, AFFES (Plans), been notified?

Have the TFE staffing, stock assortment, security, facility, transportation, and communications requirements been identified and coordinated?

Is finance support for the TFE identified?

FM 701-58

Has the policy on rationing and check cashing been determined?

h. Class VII.

Does the plan specify the equipment level for deploying units?

Are equipment redistribution requirements specified?

Are replacement actions for salvage equipment specified?

Are special equipment requirements addressed?

Are ORF requirements addressed?

i. Class VIII.

Are procedures unique to medical supply described?

Does this portion of the logistics support plan complement the medical support plan?

Are resupply procedures established?

Are MPL/PLL requirements specified?

Are ASL objectives addressed?

Are DX and MEDSTEP addressed?

Are special medical equipment and supply requirements identified based on medical mission and the area of operations?

Are special storage requirements satisfied?

Is the disposal of salvage medical supplies addressed?

Are medical oxygen and other medical gas requirements identified and resupply procedures established?

j. Class IX.

Are PLL requirements specified?

Are ASL requirements, including reparable, specified?

Are cannibalization procedures addressed?

Are requirements for special nonexpendable components addressed?

Will the GS base support the Class IX supply system?

What are the AIMI requirements and procedures?

Is a stockage of major assemblies addressed?

k. Class X.

If Class X materiel is required, does the plan describe the source?

What is the source of funding for Class X supplies?

B-8. Maintenance.

Does the plan describe how unit, intermediate (direct support), and intermediate (general support) maintenance will be performed?

Is missile maintenance support available in the area of operations?

Is MEMO considered?

Are special medical maintenance requirements addressed?

Are AVIM/AVUM aspects addressed?

Does the plan cover TMDE repair and calibration?

Are procedures for AOAP specified?

Does the plan address equipment classification?

Are there provisions for AMC LAR support?

Is direct exchange addressed?

Is operational readiness float addressed?

How will repairs under warranty be performed in the area of operations?

Is the evacuation of reparable addressed?

How will contaminated equipment affect maintenance operations?

B-9. Transportation.

a. General.

Are the transportation support systems for DSS/ALOC described?

Does the deploying force have the authorized, assigned, and available training personnel and equipment to accomplish its mission?

Does the deploying force require augmentation?

What are SEALOC requirements? Can containers be used with carrier delivery direct to SSA?

Is coastal line of communication required? Army freight ships? Landing craft? Lighterage?

Will a LOTS operation be required?

Have MHE requirements been addressed?

What ports are available?

What is access to/from ports?

Is oceanographic data available?

What special port clearance requirements apply?

What airfields can be used? What are their capabilities? Have the DACG/AACG requirements been satisfied?

Is there a rail system available? What are schedules and capability?

Is the highway net described? What are the capabilities and limitations?

Are the transportation movement priority and account codes provided?

What is the weather impact on ports, airfields, and highway nets?

What is the availability of Defense Intelligence Agency data/analysis regarding the country/area transportation infrastructure?

What are the transportation funding arrangements?

Are transportation account code requirements specified?

Are in-country highway, rail, air, and inland waterway mode requirements addressed?

How will adversary use of NBC weapons affect transportation operations?

Are the SPOD/SPOE and APOD/APOE specified?

Is a movement system for personnel and cargo specified (intratheater, intertheater, in-country)?

Has coordination been made with MTMC, MSC, and MAC for personnel and equipment movements?

Has MAC SAAM validating headquarters been specified?

Has the use of foreign flag sea/airlift been addressed?

Is a cut-off date for changes to UEL/AUEL specified?

Are there any special transportation requirements (Army aircraft to self-deploy, for example)?

Will refrigerated transportation be required?

Are procedures addressed for shipping supplies and equipment that arrive at home station after the unit(s) have deployed?

What support can/will be provided by the host nation, allies, or other services?

What support can/will be provided to host nation, allied, or other services?

b. Logistics Over the Shore.

What shorelines are conducive for LOTS operations?

What are the characteristics of the shorelines?

What types of roads accesses the shorelines?

What type of railroad accesses the shorelines?

What contract civilian/host nation personnel and equipment assets are available to assist in LOTS operations?

c. Inland Waterways.

What inland waterways are available?

What are the characteristics of the inland waterways?

What inland terminals are along the waterways?

What are the characteristics and capabilities of the inland terminals?

What is the present usage of the inland waterways?

What is the enemy's capability to interdict the inland waterways?

What effect does the weather have on the inland waterways?

How accessible are the inland waterways to roads and rail lines?

What are the capabilities and limitations of the inland waterways?

d. Intercostal Shipping.

What intercostal shipping assets are available to support military operations (bulk fuel, ammunition, dry cargo)?

What intercostal shipping routes are currently in use?

What is the enemy's ability to interdict intercostal shipping?

e. Containers.

What is the container policy?

What contract civilian/host nation personnel and equipment assets are available to assist intermodal operations?

What is the capability of units to handle container shipments?

f. Fixed Ports.

What fixed ports are available to support military marine terminal operations?

What are the characteristics and capabilities of the fixed ports?

What type and quantities of MHE are available for use in support of military marine terminal operations?

How many berths and anchorages will be available for use in support of military marine terminal operations?

What is the enemy's capability to interdict the ports?

What kind of port security measures are currently in use?

What is the port's capability to handle containerized cargo?

What routes access the ports? Is oceanographic data available? Are there any special port clearance requirements?

What is the current throughput capability of the port?

What are the characteristics and capabilities of the port warehouse facilities and storage area?

What effect does weather and the sea have on port operations?

What contract civilian/host nation marine terminal personnel and equipment assets are available to support military terminal operations?

What is the present level of usage of the ports?

What capability does the government/local civilian contractors have to repair damage to port facilities?

g. Airfields.

What airfields are available to support military operations?

What are the personnel and cargo reception capabilities of the airfield?

What is the current usage of the airfield?

What are the characteristics and capabilities of the roads that access the airfield?

Has support been planned for USAF Mobile Aeromedical Staging Facilities?

What contract civilian/host nation personnel and equipment assets are available to assist in arrival/departure airfield control group operations?

What airfield facilities are available for military use during AACG/DACG operations?

What impact does weather have on airfield operations?

Have the MAC channel airlift requirements been specified?

Who is tasked with arrival airfield control group mission?

h. Main Supply Routes and Alternate Supply Routes.

What routes are available to support military operations?

What are the characteristics and capabilities of the routes available to support military operations?

What are the dimensions of tunnels along the routes?

What are the dimensions and classifications of bridges along the routes?

What capability does the government have to repair damaged segments of routes?

What segments of the routes are heavily used by the civilian populace?

i. Rail.

What rail lines are available to support military operations?

What is the gauge of the tracks?

What effect does the weather have on rail operations.

What rail assets will be available to support military operations?

What is the condition of the rail lines?

What is the enemy's ability to interdict the rail lines?

What capabilities do the government or local civilian contractors have to repair damaged track, bridges, and tunnels?

What are the characteristics and capabilities of the rail terminals and marshaling yard?

What is the present level of usage of the rail lines?

What is the description (model number, wheel arrangement, horsepower, weight, tractive effort, and type coupler) of typical line-haul locomotives and switch engines currently in service in the area of operations?

What are the capacities, dimensions (length), and age of typical rolling stock currently in service in the area of operations?

Is a track profile of the main line indicating the location, percent, and length of ruling grade available?

Is a plan view showing location and length of minimum radius curves together with any sections of multiple main line track available?

What is the location and length of passing tracks on the main line?

What is the current level of traffic (trains per day) utilizing the main line in the area of operations?

What is the location, type, and capacity of rail yards in the area of operations?

What is the number and length of track in each yard?

What is the location; description (type, construction, length, clearances, and cooper rating); and condition of rail bridges and tunnels on the main line?

What is the location; description (length, clearances); and condition of railway tunnels on the main line?

What is the location, storage capacity, and condition of locomotive fueling facilities in the area of operations?

What is the location and quality of water supply on the main line?

What type of communications and signals are in use for train operations?

What is the type and location of the power source required for operation of communications and signal facilities?

What is the location, description, and condition of station facilities supporting the operation of the main line?

Are loading ramps available at rail yards and terminals?

What is the location, capacity, and condition of engine houses and car repair shop facilities in the area of operations?

What type of wheel bearings are predominantly used on rolling stock?

What is the location and availability of spare parts for motive power and rolling stock?

What is the location and lifting capacity of railway cranes in the area of operations?

What is the weight (pounds/yard) of main line rail and the predominant type of crosstie used in the area of operations?

Is any rolling stock available that is capable of carrying litter casualties?

B-10. Field Services.

Are laundry, bath, and clothing renovation requirements addressed?

Is GRREG capability provided commensurate with the expected requirement?

Are procedures for salvage collection, evacuation, and disposal covered?

Are post exchange services provided?

Are EOD support procedures addressed?

Is fire protection provided (aviation, ammunition, petroleum, base camps)?

Are procedures for trash disposal addressed?

Is mortuary support covered?

Are food service support procedures covered?

Are there provisions for local procurement/contracting service?

Are any airdrop requirements satisfied?

Are there any LAPES requirements? Other airdrop?

Are field bakery services required? Can the host nation satisfy the requirement?

What provisions have been made to obtain deliberate decon support from a chemical unit?

Are procedures specified and do units have the equipment necessary to clean equipment for redeployment to meet USDA requirements to enter the CONUS?

B-11. Miscellaneous.

Are provisions made for LOGSTAT reporting?

What are the facilities requirements to support the logistics systems? Have these requirements been incorporated into the engineer planning? Can any of the facility requirements be satisfied by host country facilities?

What are the funding aspects of logistics support?

Have all requirements been costed?

Has an account processing code been established?

Are the communications to support logistics operations provided for in the communications planning?

Are there adequate provisions in the plan for contracting support?

Are there provisions for contracting support/local purchase?

Have an adequate number of contracting officers with the proper warrant been provided?

Is finance support available to the contracting officer.

Are linguists available to support the contracting/local purchase requirements?

Are there provisions in the plan for maneuver/war damage resulting from logistics operations?

Are special Department of Agriculture cleaning requirements for retrograde equipment identified?

Are automated logistics systems procedures properly addressed?

Have backup master files been established and prepared for shipment separate from the primary master files?

Are maintainers, operators, and managers assigned and well-trained?

Are sufficient copies of user manuals on hand and current?

Are repair parts on hand and up to required levels for computer hardware including generators and other subsystems?

Have provisions been made for backup support for repair parts, hardware maintenance, and the receipt of software change packages and emergency change messages?

Have arrangements been made for telephonic assistance (functional and technical) after deployment?

Has coordination been made with the next higher supply support activity for catalog update, reconciliation schedule, and loading of supported unit DODAACs?

Have details been worked out for transmission of documents to higher echelons?

Have appropriate parameter changes been made in the automated system(s) (for example, signal and oversea deployment codes)?

Will customer units require training and are customer user manuals available for automated system support?

FM 701-58

Have individuals been trained/appointed for local procurement? Will local currency be available?

Have local procurement procedures been established?

APPENDIX C

PRE-POSITIONED EMERGENCY SUPPLY PACKAGE

This appendix contains a pre-positioned two-day emergency supply package consisting of Classes I, II and V, in a rigged, ready-for-airdrop configuration to support the assault echelon of a reinforced airborne brigade. Part I contains the total quantity of selected items of Classes I, III and V re-

quired. Part II contains the detailed pallet loading plan with identifying project codes and pallet numbers. Part III contains the total air delivery equipment (ADE) and consumable/expendable items required to rig out the pallets indicated in Part II.

PART I

List of Class I, III and V Requirements

<i>Project Code</i>	<i>DODAC</i>	<i>Item Nomenclature</i>	<i>Unit of Issue</i>	<i>Quantity</i>
<i>AGA</i>	<i>Class I</i>			
		Meal, ready to eat (MRE)	Meal	28,416 (2,368 boxes)
<i>AGB</i>	<i>Class III</i>			
		MOGAS, cmbt, 55 gal	Drum	12
		JP-4, 55 gal	Drum	24
		Fuel, diesel, 55 gal	Drum	72
<i>AGC</i>	<i>Class V—Infantry-Type Ammunition</i>			
		A071 Ctg, ball, 5.56mm	Each	1,058,400
		A068 Ctg, tracer, 5.56mm	Each	152,520
		A131 Ctg, ball-tracer, 7.62mm, linked 4-1	Each	300,000
		A136 Ctg, ball, 7.62mm match	Each	5,520
		A475 Ctg, ball, cal. .45	Each	16,000
		A577 Ctg, API, API-T, CAL.50, linked 4-1	Each	15,000
		B546 Ctg, HE, 40mm, w/fuze	Each	8,640
		C226 Ctg, illum, 81mm, w/fuze	Each	93
		C256 Ctg, HE, 81mm, w/fuze	Each	2,166
		C276 Ctg, WP, 81mm, w/fuze	Each	342
		C704 Ctg, HE, 4.2", w/fuze PD	Each	1,472
		C706 Ctg, illum, 4.2",	Each	44
		C708 Ctg, WP, 4.2", w/fuze PD	Each	350
		H110 Rkt, 66mm, incend, 4rd clips	Each	64
		H557 Rkt, HEAT, 66mm, LAW	Each	960
		M189 Ctg, impulse	Each	64
<i>AGD</i>	<i>Class V—Artillery Type Ammunition (105mm)</i>			
		C443 Ctg, HE, 105mm, w/fuze MTSQ	Each	2,816
		C445 Ctg, HE, 105mm, w/o fuze	Each	364
		C448 Ctg, HEP-T, 105mm, w/fuze	Each	72

FM 701-58

<i>Project Code</i>	<i>DODAC</i>	<i>Item Nomenclature</i>	<i>Unit of Issue</i>	<i>Quantity</i>
	C449	Ctg, illum, 105mm, w/fuze	Each	68
	C454	Ctg, WP, 105mm, w/fuze	Each	330
	N463	Fuze, prox	Each	416
<i>AGD</i>	<i>Class V—Artillery Type Ammunition (155mm)</i>			
	D544	Proj, M107, HE w/o fuze	Each	152
	D563	Proj, M483, HE	Each	624
	D579	Proj, M549, HERA	Each	144
	D550	Proj, M110, WP	Each	96
	D506	Proj, M116, HC, Smoke	Each	48
	D505	Proj, M485, Illum	Each	96
	D540	Prop Chg, M3A1, GB	Each	140
	D541	Prop Chg, M4A1, WB	Each	520
	D533	Prop Chg, M119A1, Ch 8	Each	320
	D532	Prop Chg, M203, RB	Each	240
	N335	Fuze, M557, PD	Each	208
	N248	Fuze, M565, MT	Each	48
	N278	Fuze, M1564, MTSQ	Each	160
	N285	Fuze, M577, MISQ	Each	864
	N463	Fuze, M728, VT	Each	128
	N523	Primer, M82	Each	1,500
	D552	Flash Reducers M2	Each	800
<i>AGE</i>	<i>Class V—Bulk Allotment Items</i>			
	G881	Gren, frag	Each	2,790
	G900	Gren, incend	Each	640
	G963	Gren, riot, CS, M7 series	Each	950
	G930	Gren, smk, HC	Each	736
	G940	Gren, smk, green	Each	224
	G945	Gren, smk, yellow	Each	224
	G950	Gren, smk, red	Each	224
	G955	Gren, smk, violet	Each	224
	K010	Burster, incend	Each	120
	K092	Mine, AP, M16	Each	92
	K121	Mine, AP, M14	Each	192
	K143	Mine, AP, M18	Each	270
	K181	Mine, AT	Each	84
	K768	Riot Control Agent CS1 (8-lb btl)	Pound	320
	L306	Signal, illum, cluster, red star	Each	144
	L314	Signal, illum, ground, green star cluster	Each	144
	L495	Flare, surface, trip	Each	288
	L621	Starter, fire	Each	500
	M023	Charge, demol, blk, C-4	Each	1,410
	M130	Cap, blast, elec ¹	Each	900
	M131	Cap, blast, non-elec ¹	Each	5,000
	M241	Destructor, explo, univ	Each	50
	M421	Charge, demol, shaped, 40 lb	Each	15
	M456	Cord, det	Foot	5,000
	M670	Fuze, blast, time	Foot	4,000
	M766	Igniter, time, blast	Each	600
<i>AGE</i>	<i>Class V—Armor Type Ammunition</i>			
	A165	Ctg, ball-tracer, 7.62mm, linked 4-1	Each	756,000
	D381	Ctg, HEAT-T, 152mm	Each	464

<i>Project Code</i>	<i>DODAC</i>	<i>Item Nomenclature</i>	<i>Unit of Issue</i>	<i>Quantity</i>
AGG	<i>Class V—Anti-Air Type Ammunition</i>			
	A655	Ctg, HEI & IP-T, 20mm, linked 7-1	Each	40,000
	A792	Ctg, HEI-T, 20mm, linked	Each	22,000
AGH	<i>Class V—Aviation Type Ammunition</i>			
	A165	Ctg, ball-tracer, 7.62mm, linked 4-1	Each	42,000
	A655	Ctg, HEI & IP-T, 20mm, linked 7-1	Each	20,000
	B571	Ctg, HE, 40mm, linked	Each	10,800
	H459	Rkt, APERS, 2.75 in ³	Each	240
	H826	Rkt, HEDD, 2.75 in ³	Each	208
	H488	Rkt, HE, 2.75 in ³	Each	75
	H490	Rkt, HE, 2.75 in ³	Each	2,160
	H519	Rkt, smk, WP, 2.75 in ³	Each	144
	H534	Rkt, HE, 2.75 in ³	Each	720
AGI	<i>Class V—Missile Type Ammunition</i>			
		1410-00-087-1521 TOW ²	Each	720
		1410-00-150-8932 SHILLELAGH	Each	225
		1429-00-930-9920 REDEYE ²	Each	70
		1427-00-163-8959 DRAGON ²	Each	486

Notes:

¹ For safety precautions, items are rigged on pallet #125, Project Code AGC.

² MICOM managed items, all other class V items AMCCOM managed.

³ Requires 2 each cargo bag, A-22 per pallet.

PART II
Detailed Pallet Loading Plan, Emergency Supply Package

<i>Project Code</i>	<i>Pallet No.</i>	<i>Item Nomenclature</i>	<i>Qty per Pallet</i>	<i>Wgt per Pallet W/ADE</i>
AGA	<i>Class I (37 Pallets)</i>			
	1-37	Meal, ready to eat (MRE).....	768 (64 bx)	1,288
AGB	<i>Class III (27 Pallets)</i>			
	1-3	MOGAS, cbt, 55-gal drum.....	4	1,996
	4-9	JP-4, 55-gal drum.....	4	1,995
	8-27	Fuel, diesel, 55-gal drum.....	4	1,996
AGC	<i>Class V—Infantry Type (125 Pallets)</i>			
	1-22	A071 Ctg, ball, 5.56mm.....	47,040	2,076
	23-25	A068 Ctg, tracer, 5.56mm.....	50,840	2,081
	26-40	A131 Ctg, ball, tracer, 7.62mm, linked 4-1.....	20,000	2,075
	41-43	A577 Ctg, API, API-T, cal. .50, linked 4-1.....	5,000	2,075
	44-47	B546 Ctg, HEDP, 40mm.....	2,160	2,095
	48-66	C256 Ctg, HE, 81mm w/fuze PD.....	114	2,100
	67-68	C276 Ctg, WP, 81mm w/fuze PD.....	63	1,260
	69-70	C276 Ctg, WP, 81mm w/fuze PD.....	108	2,085
	71	C226 Ctg, illum, 81mm, w/fuze.....	93	1,705

Project Code	Pallet No.	Item Nomenclature	Qty per Pallet	Wgt per Pallet W/ADE
	72	<i>Mixed Pallet</i>		
		H110 Rkt, incend, 166mm, 4rd clips.....	64	
		M189 Ctg, impulse	64	
		A136 Ctg, ball, 7.62mm match	5,520	
		Total Weight		1,365
	73-104	C704 Ctg, HE, 4.2", w/fuze PD.....	46	2,086
	105-111	C708 Ctg, WP, 4.2", w/fuze PD	50	2,075
	112	C706 Ctg, illum, 4.2" w/fuze	44	2,048
	113-124	H557 Rkt, HE, 66mm, LAW	80	920
	125	<i>Mixed Pallet</i>		
		A071 Ctg, ball, 5.56mm.....	23,520	
		A475 Ctg, ball, cal. .45	16,000	
		M130 Cap, blast, elec ²	900	
		M131 Cap, blast, non-elec ²	5,000	
		Total Weight		2,235
AGD	<i>Class V—Artillery—105MM (116 Pallets)</i>			
	1-75	C443 Ctg, HE, 105mm, w/fuze, MTSQ.....	32	2,024
	76-77	C448 Ctg, HEP-T, 105mm, w/fuze	36	2,090
	78-79	C449 Ctg, illum, 105mm, w/fuze	34	2,008
	80-90	C454 Ctg, WP, 105mm, w/fuze PD.....	30	2,000
	91-116	<i>Mixed Pallets</i>		
		C443 Ctg, HE, 105mm, w/fuze, MTSQ.....	16	
		C445 Ctg, HE, 105mm, w/o fuze	14	
		N463 Fuze, prox	16	
		Total Weight		1,966
	117	<i>Mixed Pallet</i>		
		D563 Proj, HE, 155mm, M483	10	1,026
		D541 Prop Chg, WB	10	445
		N523 Primer, M82	1 Bx	63
		Total Weight		1,734
	118	<i>Mixed Pallet</i>		
		D563 Proj, HE, 155mm, M483	10	1,026
		D541 Prop Chg, WB	10	445
		D552 Flash Reducer	1 Bx	68
		N335 Fuze, PD.....	1 Bx	59
		Total Weight		1,798
	119-133	<i>Mixed Pallets</i>		
		D563 Proj, HE 155mm, M483	10	1,026
		D533 Prop Chg, Ch 8.....	10	700
		N285 Fuze, MISQ.....	1 Bx	44

<i>Project Code</i>	<i>Pallet No.</i>	<i>Item Nomenclature</i>	<i>Qty per Pallet</i>	<i>Wgt per Pallet W/ADE</i>
		Total Weight		1,970
134-151	<i>Mixed Pallets</i>			
	D563	Proj, HE, 155mm, M483	10	1,026
	D541	Prop Chg, WB	10	445
	N285	Fuze, MTSQ.....	1 Bx	44
		Total Weight		1,715
152-165	<i>Mixed Pallets</i>			
	D563	Proj, HE, 155mm, M483	10	1,026
	D533	Prop Chg, Ch 8.....	10	700
	N285	Fuze, MTSQ.....	1 Bx	44
		Total Weight		1,970
166-176	<i>Mixed Pallets</i>			
	D563	Proj, HE, 155mm, M483	10	1,026
	D532	Prop Chg, RB, M203.....	10	550
		Total Weight		1,776
177	<i>Mixed Pallets</i>			
	D544	Proj, HE, 155mm	10	950
	D541	Prop Chg, WB	10	445
	N523	Primer, M82	1 Bx	62
		Total Weight		1,657
178-181	<i>Mixed Pallets</i>			
	D544	Proj, HE, 155mm	10	950
	D541	Prop Chg, WB	10	445
	N335	Fuze, MTSQ.....	1 Bx	59
		Total Weight		1,654
182-186	<i>Mixed Pallets</i>			
	D544	Proj, HE, 155mm	10	1,400
	D541	Prop Chg, WB	10	700
	N278	Fuze, MTSQ.....	1 Bx	63
		Total Weight		1,658
187-190	<i>Mixed Pallets</i>			
	D544	Proj, HE, 155mm	10	950
	D540	Prop Chg, GB	10	300
	N278	Fuze, MTSQ.....	1 Bx	63
		Total Weight		1,513

FM 701-58

<i>Project Code</i>	<i>Pallet No.</i>	<i>Item Nomenclature</i>	<i>Qty per Pallet</i>	<i>Wgt per Pallet W/ADE</i>
191-198	<i>Mixed Pallets</i>			
		D579 Proj, HERA, 155mm	10	950
		D532 Prop Chg, RB, M203.....	10	550
		N463 Fuze, VT	1 Bx	63
		Total Weight		1,563
199-203	<i>Mixed Pallets</i>			
		D579 Proj, HERA, 155mm	10	950
		D532 Prop Chg, RB, M203.....	10	550
		N285 Fuze, MTSQ.....	1 Bx	44
		Total Weight		1,744
204	<i>Mixed Pallets</i>			
		D579 Proj, HERA, 155mm	10	950
		D533 Prop Chg, Ch 8.....	10	700
		N335 Fuze, PD.....	1 Bx	59
		Total Weight		1,909
205-207	<i>Mixed Pallets</i>			
		D506 Proj, HC, Smk, 155mm	10	950
		D540 Prop Chg, GB	10	300
		N248 Fuze, MT.....	1 Bx	55
		Total Weight		1,505
208	<i>Mixed Pallet</i>			
		D506 Proj, HC, Smk, 155mm	10	950
		D541 Prop Chg, WB	10	445
		N523 Primer, M82	1 Bx	62
		Total Weight		1,657
209	<i>Mixed Pallet</i>			
		D506 Proj, HC, Smk, 155mm	8	760
		D544 Proj, HE, 155mm	2	190
		D541 Prop Chg, WB	10	445
		N278 Fuze, MTSQ.....	1 Bx	63
		Total Weight		1,658
210-218	<i>Mixed Pallet</i>			
		D505 Proj, Illum, 155mm	10	920
		D541 Prop Chg, WB	10	445
		Total Weight		1,565
219	<i>Mixed Pallet</i>			
		D505 Proj, Illum, 155mm	6	552
		D579 Proj, HERA, 155mm	4	380

Project Code	Pallet No.	Item Nomenclature	Qty per Pallet	Wgt per Pallet W/ADE
		D541 Prop Chg, WB	14	420
		Total Weight		1,552
220-224	Mixed Pallets			
		D550 Proj, WP, 155mm.....	10	990
		D541 Prop Chg, WB	10	445
		N335 Fuze, PD.....	1 Bx	59
		Total Weight		1,907
225-228	Mixed Pallets			
		D550 Proj, WP, 155mm.....	10	990
		D541 Prop Chg, WB	10	445
		Total Weight		1,635
229	Mixed Pallet			
		D550 Proj, WP, 155mm.....	6	594
		D563 Proj, HE, 155mm, M483	4	410
		D541 Prop Chg, WB	10	445
		N335 Fuze, PD.....	1 Bx	59
		Total Weight		1,708
230-231	Mixed Pallets			
		D563 Proj, HE, 155mm, M483	10	1,026
		D533 Prop Chg 2, Chg 8.....	10	700
		N285 Fuze, MTSQ.....	1 Bx	44
		Total Weight		1,970
232	Mixed Pallet			
		D544 Proj, HE, 155mm	10	950
		N335 Fuze, PD.....	1 Bx	59
		Total Weight		1,248
AGE	Class V—Bulk Allotment Items (18 Pallets)			
	1-3	G881 Gren, frag, M67	930	2,058
	4	G900 Gren, incend, AN-M14.....	640	2,080
	5	G930 Gren, smk, HC	736	2,086
	6	G963 Gren, riot, CS.....	950	1,150
	7-8	K143 Mine, AP.....	120	1,460
	9	M023 Charge, demo, blk, C-4.....	1,050	2,085
	10	Mixed Pallet		
		M023 Charge, demo, blk,	C-4	360
		M766 Igniter, time, blast	600	
		L621 Starter, fire, NP	500	
		M456 Cord, det.....	5,000	
		M241 Destructor, explo, M10	50	

Project Code	Pallet No.	Item Nomenclature	Qty per Pallet	Wgt per Pallet W/ADE
		M670 Fuse, time, blast	4,000	
		Total Weight		1,243
11-13	Mixed Pallets			
		K181 Mine, AT, M21	28	
		M421 Charge, demo, shaped, 40 lb	5	
		Total Weight		1,135
	Mixed Pallets			
		G940 Gren, smk, green, M18	224	
		G945 Gren, smk, yellow, M18	224	
		Total Weight		1,200
15	Mixed Pallet			
		G950 Gren, smk, red, M18	224	
		G955 Gren, smk, violet, M18	224	
		Total Weight		1,200
16	Mixed Pallet			
		K121 Mine, AP, NM. M14	192	
		K092 Mine, AP, M16	92	
		K143 Mine, AP, M18	30	
		Total Weight		1,554
17	K768	Riot control agent, CS (8 lbs btle).....	40	994
18	Mixed Pallet			
		L306 Signal, illum, red, star cluster	144	
		L314 Signal, illum, ground, green star cluster	144	
		L495 Flare, surf, trip, M49	288	
		K010 Burster, incend, M4	120	
		Total Weight	1,517	
AGE	Class V—Armor Type Ammunition (61 Pallets)			
	1-30	A165 Ctg, ball, tracer, 7.62mm, linked 4-1	24,000	2,060
	31-32	A165 Ctg, ball, tracer, 7.62mm linked 4-1	18,000	1,580
	33-61	D381 Ctg, HEAT-T, 152mm	16	1,965
AGG	Class V—Anti Air Ammunition (31 Pallets)			
	1-20	A655 Ctg, HEI & TP-T, 20mm, linked 7-1 (Vulcan).....	2,000	2,040
	21-31	A792 Ctg, HEI-T-SD, tracer, 20mm, linked (Vulcan).....	2,000	2,040
AGH	Class V—Aviation Type Ammunition (89 Pallets)			
	1-2	A165 Ctg, ball, tracer, 7.62mm, linked 4-1	21,000	1,965
	3-12	A655 Ctg, HEI-TP-T, 20mm, linked 7-1 (COBRA only)..	2,000	2,150
	13-18	B571 Ctg, HE, 40mm, linked	1,800	2,108
	19-24	B459 Rkt, APERS, 2.75 in ⁴	40	1,600

Project Code	Pallet No.	Item Nomenclature	Qty per Pallet	Wgt per Pallet W/ADE
	25-28	H826 Rkt, HEDP, 2.75 in ⁴	64	1,955
	29	H488 Rkt, HE, 2.75 in ⁴	50	2,300
	30	H488 Rkt, HE, 2.75 in ⁴	25	1,325
	31-68	H490 Rkt, HE, 2.75 in ⁴	56	1,980
	69	H490 Rkt, HE, 2.75 in ⁴	32	1,530
	70-72	H519 Rkt, smk, WP, 2.75 in ⁴	48	1,890
	73-88	H534 Rkt, HE, 2.75 in ⁴	44	1,982
	89	H534 Rkt, HE, 2.75 in ⁴	16	948

AGI Class V—Missile Type (61 Pallets)

1-60	1410-01-106-8514, TOW ³	12	1,435
61-92	1427-00-163-8959, DRAGON ³	15	1,155
93	1427-00-163-8959, DRAGON ³	6	658
94-118	1410-00-150-8932, SHILLELAGH ³	9	1,545
119-123	1429-00-930-9920, REDEYE ³	12	1,530
124	1429-00-930-9920, REDEYE ³	10	1,400

Notes:

¹ All total weights include 200 pounds for weight of air delivery equipment (ADE).

² These bulk allotment items, Project Code AGE, are loaded on pallet #125, Project Code AGC, for safety precautions.

³ MICOM-managed items, all other class V items AMCCOM managed.

⁴ Requires 2 each cargo bag, A-22 per pallet.

PART III

List of Air Delivery Equipment (ADE) Required To Rig Pre-positioned Supply

Item No.	NSN	Item Description	Unit	Total Qty Req	Note
<i>USA GMPA New Cumberland</i>					
1	7510-00-663-0196	Tape, adhesive, 2 in	ro	104	1
2	8135-00-664-6958	Cushioning, matl, cellulose	ft	1,873	2
3	4020-00-240-2146	Cord, nylon, type III	yd	4,532	3

Notes:

1—One roll per six bag, A-22.

2—Three feet per bag, A-22.

3—Six yards per bag, A-22; 1.3 yards per G-12D cargo prcht.

USA SPT Act—Philadelphia

1	8305-00-244-0214	Cloth, ctn, muslin.....	yd	1,762	2
2	8310-00-917-3944	Thread, ctn, nat, 4 ply	tu	9	3
3	8310-00-917-3945	Thread, ctn, nat, 7 ply	tu	7	1, 4
4	8305-00-268-2411	Webbing, tex, ctn, 80 lb.....	yd	4,412	5
5	8305-00-082-2453	Webbing, tex, tubular, nylon, ½ inch.....	yd	2,497	6
6	8305-00-177-5069	Webbing, nylon, type XXVI, Natural.....	ft	2,200	7

Notes:

1—Estimate 1 spool per 500 short tons.

2—One yard per G-12D cargo prcht; 1 yard per bag, A-22.

3—Ten yards per G-12D cargo prcht.

FM 701-58

- 4—Three yards per G-12D cargo prcht; 2 yards per prcht 15 feet.
- 5—One yard per bag, A-22; 5.7 yards per G-12D cargo prcht; 2 yards per extraction prcht 15 feet.
- 6—Four yards per bag, A-22.
- 7—Twenty feet per six bags, A-22.

<i>Item No.</i>	<i>NSN</i>	<i>Item Nomenclature</i>	<i>Unit</i>	<i>Total Qty Req</i>	<i>Note</i>
TROSCOM					
1	1670-00-883-1654	Skid, board, cargo.....	ea	791	5
2	1670-00-738-5878	Strap, connector, nylon, 60 inches long	ea	916	1
3	1670-00-753-3928	Pad, energy dissipating expanded, 96 inches long, 36 inches wide, 3 inches thick.	ea	1,226	2
4	1670-00-893-2371	Parachute, cargo, 64 feet G-12D	ea	791	1
5	1670-00-568-0320	Band, rubber, parachute.....	ea	22	3
6	1670-00-217-2421	Link, assembly, prcht, connector	ea	1,828	4
7	1670-00-937-0271	Tiedown, assembly, cargo	ea	676	6
8	8465-00-587-342	Bag, cargo, air delivery w/o skid.....	ea	860	7

Notes:

- 1—One per A-22 cargo bag; plus 12 for safety level.
- 2—One and one-half pad for each A-22 cargo bag; plus 60 for safety level.
- 3—Three per G-12D cargo prcht.
- 4—Two per strap, connector, nylon, 60 inches.
- 5—One per bag, cargo, Type A-22; plus 12 for safety level.
- 6—Eight per 10 TOW and 4 per 9 SHILLELAGH.
- 7—Includes 12 for safety level.

Appendix D

DISASTER RELIEF SERVICES

<i>Type Service</i>	<i>Scope</i>
D-1. Communications.	
<i>a. Local Communications</i>	Military-type communications within the disaster area headquarters site when jointly occupied by military, FEMA, and public officials.
<i>b. Intradisaster Area Communications</i>	Military-type (mobile and tactical) communications for use by FEMA and key public officials on an austere basis within the disaster area.
<i>c. Interarea Communications</i>	Interarea communications between the disaster area and governmental and/or commercial communications access points outside the disaster area.
<i>d. Communications Administrations</i>	Assistance to local officials in supervision, operation and reestablishment of all forms of public communications and communications systems including telephone, telegraph, radio, and television within the disaster area.
D-2. Debris Clearance.	
Debris Clearance	Earthmoving equipment, with operators, to clear debris from damaged areas and roadways.
D-3. Evacuation.	
<i>a. Medical Evacuation</i>	Helicopter evacuation of casualties with inflight medical treatment and/or surveillance to medical treatment facilities from outlying areas inaccessible to ground vehicles. Ground ambulance evacuation of patients.
<i>b. Disaster Victim</i>	Helicopter evacuation of disaster victims, from outlying, inaccessible, or endangered areas to care and control facilities. Ground evacuation for mass displacement of disaster victims.
<i>c. Disaster Victim Administration</i>	Assistance to local government in coordinating the processing and control of disaster victims and in supervising the establishment, administration, and operation of temporary shelters.
D-4. Search and Rescue.	
Aerial Search and Rescue	Search and rescue service using fixed and rotary wing aircraft to find and remove persons to safe areas or rescue centers.
D-5. Food.	
<i>a. Mass Feeding</i>	Field-type mess facilities operated by military personnel and issue emergency subsistence, when authorized.
<i>b. Water Supply</i>	Potable water for emergency drinking and cooking purposes. Water hauling capability and chemicals for water purification.
<i>c. Food Administration</i>	Food service assistance to local government in surveying availability of local food and supplies and in supervising the storage, transportation, and distribution of consumer goods and commodities made available by the Armed Forces and other agencies.
D-6. Field Services and Health Services	
<i>a. Graves Registration and Mass Burial</i>	Personnel and equipment to prepare necessary graves registration records and to supervise and establish temporary cemeteries.
<i>b. Determination of Nuclear, Biological or Chemical (NBC) Contamination</i>	Trained personnel and equipment to contain, neutralize, or destroy hazardous materials, decontaminate the accident site, provide security during the operation, and maintain control over the site until such time as relieved by competent authority.

<i>Type Service</i>	<i>Scope</i>
c. Field Sanitation	Trained specialists to plan and supervise health education programs to include basic sanitation, personal health, and field sanitation team training.
d. Emergency Medical Treatment	Early care to injured or sick by trained medical personnel.
e. Emergency Hospitalization	Hospitalization to personnel when temporary hospital facilities are required.
f. Preventive Medicine	Professional consultation services, port, and training in the fields of medical epidemiology and medical zoology, sanitary engineering, and veterinary aspects of zoonotic and food borne disease control. Mass immunizations as required.
g. Medical Sorting	Receiving, sorting, and providing emergency or resuscitative treatment for patients until evacuated.
h. Insect and Rodent Control	Field surveys, investigate, and evaluate significant environmental health factors. Control of significant disease reservoirs in the civilian population and indigenous animals.
i. Veterinary Service	Food hygiene, safety, and quality assurance inspection; zoonotic disease control; emergency veterinary treatment; and veterinary care for privately owned animals as authorized (including immunization).
j. Health Administration	Preventive medicine specialist to provide assistance to local government in establishing programs for the control, treatment, and prevention of existing diseases; in providing measures for protection of food and water supplies; and in supervising maintenance of public health facilities and records.

D-7. Housing and Shelter.

a. Emergency Housing	Housing at military installations having facilities in excess of operational requirements.
b. Emergency Construction	Erection of tent facilities utilizing military personnel. Engineer troop effort for emergency construction, when directed.
c. Housing Administration	Assistance to local government in the supervision and coordination of private and governmental labor agencies; in determining the availability of local labor needed to support and effect rehabilitation of facilities within the disaster area; and in effecting arrangements to provide the labor needs from the local area.

D-8. Pollution Control.

Oil and Hazardous Materials Pollution Control	Assistance in control of a spill or oil or other hazardous materials in navigable US waters as provided for in the National Multi-Agency Oil and Hazardous Materials Pollution Contingency Plan.
---	--

D-9. Protective of Life and Property.

a. Maintenance of Law and Order	When authorized by proper authority, specialized military police units to assist local police agencies in maintenance of law and order. (Forces for this capability will be provided under the authority of GARDEN PLOT.)
b. Prevention of Looting and Plundering	When authorized by Proper authority, active military forces to assist local civilian authority in prevention of looting and plundering within the disaster area. (Forces for this capability will be provided under the authority of GARDEN PLOT.)
c. Firefighting	Assistance in suppression of forest fires by providing earthmoving equipment with operators to clear fire breaks. Units to provide a workforce for firefighting activities. Firefighting equipment with operators to suppress fires in communities near Army installations.
d. Police Administration	Assistance to local government in supervising the activities of police departments and fire departments within disaster area.

<i>Type Service</i>	<i>Scope</i>
D-10. Streets, Roads, and Bridges.	
<i>a.</i> Emergency Repair	Emergency repairs to streets, roads, and bridges utilizing engineer troop effort. Replace damaged bridging with temporary types; e.g., floating and/or panel bridges.
<i>b.</i> Public Works Administration	Engineer assistance to local government in supervising operations of public works department within the disaster area and in coordinating the utilization of resources provided by other agencies.
D-11. Transportation and Traffic Control.	
Emergency Land, Sea, and Air Transportation	Land and emergency airlift transportation for the movement personnel and supplies utilizing military vehicles not required for the accomplishment of primary missions.
D-12. Other.	
<i>a.</i> Restoration of Utilities	Limited engineer troop support in the repair of water, sewer, and low level voltage systems.
<i>b.</i> Emergency Power supply	Generators from available Army resources. Construct limited low-voltage distribution systems.
<i>c.</i> Damage Assessment	Personnel, with surface or air transportation, as required, to establish the location, nature, and extent of the emergency. Determine the type and amount of military resources required to supplement civilian efforts.
<i>d.</i> Explosive Ordnance Disposal	Capability to neutralize the hazards existing in explosive ordnance which, because of unusual circumstance, present a possible threat to operations, installations, personnel, or materiel. This includes the detection, identification, field evacuation, and disposal of explosive ordnance which has been fired, dropped, launched, projected, or placed in such a manner as to constitute a hazard. Includes all ordnance containing high explosives, fissionable or radioactive materials, fusion fuel, and chemical or biological agents.
<i>e.</i> Emergency Flood Control	Specialized engineer equipment with operators such as dozers, road-graders, front loaders, power shovels, scrapers, earthmoving, roller sheepsfoot, dump truck and cranes. Also, units to provide a work force for filling sandbags and construction of emergency barriers.
<i>f.</i> Preservation of Art Treasures and Cultural Objects	Supervise the identification, recording, custody, safeguarding, and disposition of works of art, religious edifices/monuments, archeological or historic objects, archives and official public records within the involved area.
<i>g.</i> Public Information	Advice and assistance to local government in reviewing the facilities employed to disseminate information to the people; coordinating the operation of public communication media and in planning, directing and supervising the preparation, distribution and dissemination of necessary information through private or public agencies within the involved area.
<i>h.</i> Emergency Demolitions	Explosives and trained personnel to perform necessary demolition tasks to include blasting ice masses threatening bridges and dams or creating firebreaks.

APPENDIX E
SAMPLE FORMAT OF REPORT OF OPERATIONS COSTS (US ARMY)
TO ANNEX ____ (REPORTS) TO MACOM OPLAN

(Thousands of \$)

		<i>Incremental</i>			
	<i>Total</i>	<i>Nor- mal</i>	<i>Reim- burse- others</i>	<i>Reimburse fm others</i>	<i>Net</i>
<i>a. Dollar Costs:</i>					
(1) Military Personnel, Army (MPA).	_____	_____	_____	_____	_____
(a) Active Duty.	_____	_____	_____	_____	_____
(b) National Guard called to Federal service and mobilized USAR.	_____	_____	_____	_____	_____
(c) NGPA (Savings).	()	_____	_____	_____	_____
(d) RPA (Savings).	()	_____	_____	_____	_____
TOTAL MPA	_____	_____	_____	_____	_____

(Thousands of \$)

		<i>Incremental</i>			
	<i>Total</i>	<i>Nor- mal</i>	<i>Reim- burse to others</i>	<i>Reimburse fm others</i>	<i>Net</i>
(2) Procurement Appropriations.	_____	_____	_____	_____	_____
(a) Issues to military forces.	_____	_____	_____	_____	_____
(b) Assistance to other Federal agencies (identify separately by agency).	_____	_____	_____	_____	_____
TOTAL Procurement Appropriations	_____	_____	_____	_____	_____
(3) Operations and Maintenance. *	_____	_____	_____	_____	_____
(a) Temporary duty costs.	_____	_____	_____	_____	_____
1 Military.	_____	_____	_____	_____	_____
2 Civilian.	_____	_____	_____	_____	_____

(Thousands of \$)

		<i>Incremental</i>			
	<i>Total</i>	<i>Nor- mal</i>	<i>Reim- burst to others</i>	<i>Reimburse fm others</i>	<i>Net</i>
(b) Civilian overtime.	_____	_____	_____	_____	_____
(c) Transportation.	_____	_____	_____	_____	_____
1 USAF transportation.	_____	_____	_____	_____	_____

(Thousands of \$)

	<i>Total</i>	<i>Nor- mal</i>	<i>Incremental</i>		<i>Net</i>
			<i>Reim- burse to others</i>	<i>Reimburse fm others</i>	
2 Military motor transport.	_____	_____	_____	_____	_____
3 Army air transportation.	_____	_____	_____	_____	_____
(d) Assistance to other Federal agencies (identify separately by agency).	_____	_____	_____	_____	_____
(e) Support to National Guard on State status.	_____	_____	_____	_____	_____
(f) Support to other DOD components and agencies (identify separately).	_____	_____	_____	_____	_____

(Thousands of \$)

	<i>Total</i>	<i>Nor-</i>	<i>Incremental</i>		<i>Net</i>
			<i>Reim- burse to others</i>	<i>Reimburse fm others</i>	
(g) Support to civilian law enforcement agencies (identify separately).	_____	_____	_____	_____	_____
(h) Construction costs (identify individual line items whose cost exceeds \$500 per line).	_____	_____	_____	_____	_____
(i) Materiel and supplies.	_____	_____	_____	_____	_____
(j) Other OMA costs (identify individual line items whose cost exceeds \$500 per line).	_____	_____	_____	_____	_____
*TOTAL OMA	_____	_____	_____	_____	_____

b. Number of Forces Employed:

<i>Active</i>		<i>Reserve</i>		<i>National Guard in Federal Service</i>		<i>Total</i>	
<i>Off</i>	<i>Enl</i>	<i>Off</i>	<i>Enl</i>	<i>Off</i>	<i>Enl</i>	<i>Off</i>	<i>Enl</i>

 .If OMAR incremental costs are incurred, they will also be shown in this paragraph under subparagraph a(4), Operations and Maintenance, Army Reserve.

APPENDIX F

LOGISTICS STATUS REPORT TO ANNEX _____ (REPORTS) TO MACOM OPLAN

F-1. General.

A logistics status report (LOGSTAT) will be submitted to MACOM for the purpose of keeping the CDR informed of the logistics status of deployed OPLAN forces.

F-2. Report Submission.

a. Preparing Agency. Base support installations (BSI) commanders in whose area forces are deployed. Preparation responsibility may be delegated to the Task Force Commander(s) or LLT(s).

b. Frequency. Daily.

c. Submission Requirements. Reports will be as of 0400Z of the initial day that forces are deployed, and as of 0400Z each day thereafter. Reports will be telephoned to the MACOM Operations Center (FOC) not later than 0700Z following the "as of period" and confirmed by followup message to be dispatched not later than 1200Z.

F-3. Supply Status in Deployment.

The report will provide information concerning supply status of forces deployed as follows:

a. Supplies.

(1) *Class I.*

(a) Type ration provided.

(b) When provided during reporting period.

(2) *Class V.* (Reported only when forces are required to perform Civil Disturbance Operations.)

(a) Small arms.

1 Number rounds by type on hand.

2 Number rounds expended (cumulative on daily basis).

(b) Riot control munitions.

1 Number Grenades, CS, M7, M25, by type on hand.

2 Number Grenades, CS M7, M25, by type expended (cumulative on daily basis).

b. Services.

(1) Method of feeding; e.g., unit mess, contract mess (meals or box lunches), MRE, garrison, field mess.

(2) Laundry.

(a) Method of providing.

(b) Time required for turnaround.

(3) Bath.

(a) Method of providing.

(b) Capacity.

F-4. Equipment Status.

Provide information as to status of the following in the objective area:

a. Quantity of general-purpose vehicles (excluding trailers) with forces.

b. Quantity of special-purpose vehicles by type (i.e., vehicles other than utility or cargo type) with forces.

c. Quantity of tank and APCs by type with forces.

d. Vehicles (by type; e.g., sedan, bus, truck) contracted from commercial sources.

e. Riot control weapons: M3, M106, M4, and M5 Dispersers by type with forces.

f. Aircraft with forces:

(1) Fixed wing, by type.

(2) Helicopters, by type.

F-5. Shortages.

Report significant shortages of supplies and/or equipment which affect, or may affect, the accomplishment of the mission.

F-6. Maintenance Deficiencies.

Report major maintenance deficiencies which can be resolved locally.

F-7. Special Instructions.

a. Report "not applicable (NA)" for subparagraphs as appropriate.

b. After the initial report indicate "no change" for each subparagraph as applicable.

APPENDIX G

SUBMISSION OF MOVEMENT REQUIREMENTS

TO ANNEX ____ (REPORTS) TO MACOM OPLAN

MOVEMENT REQUIREMENTS REPORT

(Movement by Military Air Only)

G-1. Purpose.

To establish movement requirements for the deployment and redeployment of units in support of operation plan.

G-2. Preparing Agencies.

Installation Transportation Office/Division Transportation Office as appropriate.

G-3. Movement Requirements Submission.

a. Participating units/forces cannot be predetermined; therefore, rapid, accurate reporting at the time they are so designated is essential.

b. Air movement requirements of all Army elements in support of OPLAN GRAPHIC HAND will be reported by the installation's transportation office/division transportation office (as appropriate) to MACOM Operations Center with confirmation by priority message. Requirements will be provided in the following format: (In accordance with AR 59-9.)

(1) *Overall Security Classification of SAAM.* (Special weapons movement will carry a minimum classification of restricted data to identify movements.)

(2) *Mission Number Assigned by the Requesting Department.*

(3) *Priority Assigned* (as explained in section III).

(4) *Unit and Project Name* (or nickname).

(5) *Route.* (All of the following to be identified by airfield, e.g. Anderson AFB vice Guam.)

(a) Onload.

(b) En route stops.

(c) Offload.

(6) *Dates.* Do not request specific times unless absolutely necessary. If specific times are requested, use "Z" or "GMT" time, not local time. If more than one onload/offload, give availability, desired pickup, and delivery of each.

(a) Availability.

(b) Date pickup is desired.

(c) Date delivery is required.

(7) *Passengers.*

(a) Total number of passengers. If a cargo SAAM requirement, indicate names of passengers who may be couriers, technical escorts, or foreign nationals.

(b) Total weight of excess *baggage*—do not include normal baggage weight.

(8) *Cargo Measurements.*

(a) short tons of cargo, to the nearest ton. Do not include baggage weight.

(b) Total cube (cubic feet).

(9) *Security Classification of Cargo.* If cargo is unclassified, so indicate.

(10) *Commodity Description and Any Other Pertinent Information.* Use complete service nomenclature and Department of Transportation (DOT) shipping name and class, if appropriate.

(11) *Weight and Dimension.*

(a) Weight of the largest single item (LSI) in pounds, followed by cube. Example: 780/95.

(b) Dimension of the largest single item in inches; specify length, width, and height. See descriptions of outsize and oversize cargo. Indicate in remarks section all wheeled or skid-mounted cargo exceeding 104" in length, 60" in width, or 48" in height.

FM 701-58

(12) *Net Explosive Weight.* Indicate in the remarks section the net explosive weight (NEW) by class and quantity—distance (Q-D) class of each item containing class A or B explosives. (For special weapons, provide the number and type units, type container, unit weight, net explosive weight, and total weight in the onload/offload order. Data must be derived from TO 1 IN-45-51 and TO 11N-45-51 A(A).)

(13) *Identify Appropriate Paragraphs of 71-4/DSAM 4145.3/TM 38-250/NA VSUP PUB 505/MCOP 4030-19.* Identify each dangerous item and cite all applicable lowest subparagraph in compliance thereto for each item. (Use remarks section, if necessary.) Dangerous materials are not airlifted unless all provisions of subject manual have been complied with.

(14) *Contacts.* Indicate full names, office, and home phone numbers, including AUTOVON or commercial, as applicable, of two individuals at each stop.

(a) Onload.

(b) En route.

(c) Destination.

(15) *Billing Instructions.* Include the CIC, TAC, or appropriation chargeable, as appropriate. If

none of these are available, include the name and address of a specific organization responsible for reimbursing on direct billing basis.

(16) *Remarks.* Add the following:

(a) Geographic location of information addresses. The addresses must be identified fully, for example-COMNAV-AIRPAC, San Diego, CA.

(b) If internal office symbol is required, it must also be furnished.

(c) Justification for short notice clearance of cargo and aircraft. This justification must include detailed description of commodity requiring clearance. Requirements submitted within 72 hours of desired movement date are considered an emergency. A statement as to the emergency and a justification for airlift within 72 hours must be included in this section.

(d) SAAM requirements for channel extension include the following additional information:

1 Transportation control number (TCN).

2 MAC channel mission identifier to be extended (e.g., AKA 459Y/140).

3 Contact is initial MAC channel onload station and point of channel extension.

APPENDIX H

UNIT MOVEMENT REPORT TO ANNEX ____ (REPORTS) TO MACOM OPLAN

UNIT MOVEMENT REPORT

H-1. Purpose.

To provide timely information of unit movements in support of operation _____.

H-2. Preparing Agencies.

The supporting Installation Transportation Office (ITO) is responsible for insuring adequate and timely transportation reports as required by AR 55-113.

H-3. Report Submission.

All movements of DA military elements in support of OPLAN _____ will be reported by the respective ITO to MACOM operation center by phone followed by priority message, distributed as follows:

a. Distribution:

	<i>Ad- vance Notice (Parts 1 and 2)</i>	<i>Actual Depart- ure</i>	<i>Actual Arrival</i>
Origin installation commander	O	O	A
Destination installation commander	A	A	O
DA Wash DC// DAAG-ASO-D	I	I	I
DA Wash DC// DAMO-ODG	I	I	I
DA Wash DC// DALO-TSM	I	I	I
DA Wash DC// DAPE-PBB and MPE	I		
HQ, FORSCOM// AFLG-TRU	I		
Origin installation commander	I		

	<i>Ad- vance Notice (Parts 1 and 2)</i>	<i>Actual Depart- ure</i>	<i>Actual Arrival</i>
--	---	-----------------------------------	---------------------------

Destination installation commander.....	I	I	I
En route installation commanders.....	I*	I*	

*Applicable if administrative or logistics support is to be provided or for organic highway movements transiting Army areas. LEGEND: O—Originator; A—Action addressee; I—Information.

b. Format: Reports of movements will be submitted in accordance with AR 55-113. Listed below is the preferred format:

(1) Advanced Notice of Departure (surface only). Part I—Personnel and accompanying equipment

(a) DA movement directive number.

(b) Unit designation (or unit identification code when prescribed); increment, if any.

(c) Routing symbol and/or identification number.

(d) Strength (Off, WO, EM, Civ; if applicable, identify female personnel included in totals).

(e) Origin installation.

(f) Final destination.

(g) Offload point, if different from item f.

(h) Number of railcars, commercial trucks, or convoy vehicles (specify).

(i) Delivering commercial carrier, military carrier, or final highway route for convoy movement.

(j) Estimated date-time of departure (ETD Z).

FM 701-58

(k) Estimated date-time of arrival
(ETA Z).

(l) Remarks: Include, as applicable, information regarding planned convoy en route overnight stops (RON), materials handling equipment requirements at offload railheads, and other information of this type.

Part 2—Separate Impedimenta shipment

(a) Unit designation, routing symbol, and/or identification number.

(b) Origin station.

(c) Offload destination.

(d) Number of railcars, commercial trucks, or vehicles in convoy (specify).

(e) Estimated date-time of departure
(ETD Z).

(f) Estimated date-time of arrival
(ETA Z).

(g) Include, as applicable, information on number of guards accompanying shipment or other information as in part 1, item 1.

(2) Actual Departure.

(a) DA movement directive number.

(b) Unit designation (or unit identification code when prescribed); increment, if any.

(c) Routing symbol and/or identification number.

(d) Strength (Off, WO, EM, Civ). If equipment only, specify.

(e) Origin installation.

(f) Destination.

(g) Actual date-time of departure
(Departed Z).

(h) Estimated date-time of arrival
(ET-----Z).

(i) Remarks: Report any changes from data in advance departure report. Include number of unit personnel who departed by POV if not elsewhere reported.

(j) Actual or estimated (specify) number of dependents being moved by unit personnel.

(3) Arrival.

(a) DA movement directive number.

(b) Unit designation (or unit identification code when prescribed).

(c) Routing symbol and/or identification number.

(d) Arrival point (destination installation).

(e) Actual date-time of arrival
(Arrive Z).

(f) Exceptions: Report only deviations to actual departure reports, plus pertinent remarks on delays, incidents, and other information of this type.

(g) Remarks (personnel, equipment, and/or unit).

APPENDIX I

REFERENCES FOR FM 701-58

a. <i>Army Regulations (AR).</i>		55-29	Military Convoy Operations in CONUS.
1-1	Planning, Programing, and Budgeting Within the Department of the Army.	55-30	Space Requirements and Performance Reports for Transportation Movements.
5-9	Interservice Support: Installation Area Coordination.	55-113	Movement of Units Within Continental United States.
700-9	Principles and Policies of the Army Logistics Systems.	55-162	Permits for Oversize, Overweight, or Other Special Military Movement on Public Highways in the United States.
(S) 11-11	Major Command Stockage Levels Worldwide (U).		
(C) 11-12	Logistics Priorities (U).		
30-1	Army Food Service Program.	55-355	Military Traffic Management Regulation.
30-7	Operational Rations.	55-357	Terminal Facilities Guide
30-18	Army Troop Issue Subsistence Activity Operating Procedures.	59-8/AFR 76-30	Military Airlift Command-Requirements and Submissions, Space Assignments and Allocation and Priorities.
30-19	Army Commissary Store Operating Policies.		
40-3	Medical, Dental, and Veterinary Care.	59-9	Special Assignment Airlift Mission Requirements Submission Procedures.
40-4	Army Medical Department Facilities/Activities.		
40-5	Health and Environment.	59-105	Aerial Ports.
40-61	Medical Logistics Policies and Procedures.	59-106	Operation of Air Force Air Terminals.
40-657	Veterinary/Medical Food Inspection	95-1	Army Aviation: General Provisions and Flight Regulations.
40-905	Veterinary Health Services	190-10	Security of Government Officials.
55-4	CONUS Military Installation Materiel Outloading and Receiving Capability Report.	210-23	Master Planning for Army Installations; Emergency Expansion Capability.

FM 701-58

210-130	Laundry /Drycleaning Operations.	710-1	Centralized Inventory Management of the Army Supply System.
220-10	Preparation for Oversea Movements of Units (POM).	710-2	Supply Policy Below the Wholesale Level.
310-25	Dictionary of United States Army Terms.	710-3	Asset and Transaction Reporting System.
310-50	Catalog of Abbreviations and Brevity Codes.	725-50	Requisitioning, Receipt, and Issue System.
415-16	Army Facilities Components System (Military Engineering Construction Support Designs, Materiel, and Planning Data).	735-5	General Principles, Policies, and Basic Procedures (Property Accountability).
415-35	Minor Construction.	735-11	Accounting for Lost, Damaged, and Destroyed Property.
500-1	Aircraft Piracy Emergencies.	740-1	Storage and Supply Activity Operations.
500-2	Search and Rescue Operations.	750-1	Army Materiel Maintenance Concepts and Policies.
500-50	Civil Disturbances.		
500-60	Disaster Relief.	750-7	Installation Materiel Maintenance Activities.
500-70	Military Support of Civil Defense.		
525-1	The Department of the Army Command and Control System (DACCS).	<i>b. Field Manuals (FM).</i>	
		8-8	Medical Support in Joint Operations.
525-10	The Department of the Army Command and Control Reporting System (DAXREP).	8-10	Health Service Support in a Theater of Operations.
		8-21	Health Service Support in a Communications Zone.
525-12	Noncombatant Evacuation.		
700-4	Logistics Assistance Program.	8-55	Planning for Health Service Support.
700-7	Wartime Standard Support System for Foreign Armed Forces.	10-60	Subsistence Supply and Management in Theaters of Operation.
700-22	Worldwide Ammunition Reporting System (WARS).	10-67	Petroleum Supply in Theaters of Operation.
		19-15	Civil Disturbances.
700-90	Army Industrial Preparedness Program.	20-150	National Search and Rescue Manual.
703-1	Coal and Petroleum Products Supply and Management Activities	63-2-2	Combat Service Support Operations Division (Armor, High Technology, Mechanized).
708-1	Cataloging and Supply Management Data.	63-3J	Combat Service Support Operations Corps.

63-4	Combat Service Support Operations Theater Army Area Command.	DODI 4005.3	Industrial Preparedness Production Planning Procedures.
63-5	Combat Service Support Operations Theater Army.	DOD Manual 4140.25	Military Standard Petroleum Systems.
100-10	Combat Service Support.	DODI 4160.23	Sale of Surplus Military Equipment to State and Local Law Enforcement and Fire-fighting Agencies.
100-16	support Operations: Echelons Above Corps.		
101-5	Staff Officers' Field Manual: Staff Organization and Procedure.	DODI 4400.1	DOD Priorities and Allocations Manual.
101-10-1	Staff Officers' Field Manual: Organizational, Technical, and Logistical Data.	DODI 4410.3	Policies and Procedures for the DOD Master Urgency List (MUL).
101-10-2	Staff Officers' Field Manual: Organizational, Technical, and Logistical Data Extracts of Nondivisional Tables of Organization and Equipment.	DODI 5030.50	Employment of Department of Defense Resources in Support of the United States Postal Service.
704-28	Classes of Supply.	DODD 5100.51	Protection and Evacuation of US Citizens and Certain Designated Aliens in Danger Areas Abroad.
<i>c. Technical Manual (TM).</i>			
38-250	Packaging and Materials Handling: Preparation of Hazardous Materials for Military Air Shipment.	DODD 5160.2	Single Manager Assignment for Airlift Services.
<i>d. Department of Defense Publications.</i>			
DODD 3025.1	Use of Military Resources During Peacetime Civil Emergencies Within the United States, Its Territories, and Possessions.	DODD 5160.10	Single Manager Assignment for Ocean Transportation.
DODD 3025.10	Military Support of Civil Defense.	DODD 5160.53	Single Manager Assignment for Military Traffic, Land Transportation, and Common-User Ocean Terminals.
DODD 3025.12	Employment of Military Resources in the Event of Civil Disturbances.	DODR 4500.32	Military Standard Transportation and Movement Procedures (vols. I and II)
DODI 3110.3	Requisite Characteristics for Wartime Readiness of DOD Supply Systems.	<i>e. Joint Chiefs of Staff Publications.</i>	
DODD 4000.19	Interservice, Interdepartmental, and Interagency support.	Policy #84	Joint Strategic Planing System.
DODD 4005.1	DOD Industrial Preparedness Production Planning.	1	DOD Dictionary of Military and Associated Terms.
		2	Unified Action Armed Forces (UNAAF).

FM 701-58

3	Joint Logistics and Personnel Policy and Guidance (JLPPG).	AMC LP&P	AMC Logistics Policies and Procedures for Contingency Planning (LP&P).
4	Organization and Functions of the Joint Chiefs of Staff.	SB 8-75 Series	Army Medical Department Supply Information.
6	Joint Reporting Structure (JRS).	SB 10-495	Standard "B" Ration for the Armed Forces.
7	Worldwide Military Command and Control System Standards (WWMCCSS).	SB 10-495-1	Standard "B" Hospital Rations for the Armed Forces.
15	Mobility System Policies, Procedures and Considerations	SB 10-495-2	Standard "B" Ration to be Stocked for Operational Projects and Inplace Reserves.
	US Joint Chiefs of Staff, Unified Command Plan (UCP).	SB 10-496	Supply Control; Wartime Replacement Factors and Consumption Rates for DLA/GSA Assigned Items.
	US Joint Chiefs of Staff, Joint Operation Planning System (JOPS).		
<i>f. FORSCOM Regulations.</i>		SB 38-26 (C)	Nonnuclear Ammunition Supply Rates (U).
37-11	Financial Management Plan for Emergency Conditions.	SB 700-20	Army Adopted/Other Items Selected for Authorization/List of Reportable Items.
55-1	Unit Movement Planning.		
FORSCOM/ ARRED/ARLANT Reg 525-1	Operation Planning.	SB 710-2	Supply Control; Combat Consumption Rates for Ground and Aviation Type Petroleum Products
FORSCOM/ ARRED 525-15	Narrative Operational Reporting System (U).	CTA 8-100	Allowances of Army Medical Service Expendable Supplies.
700-2	FORSCOM Standing Logistics Instructions.		
700-3	Ammunition Basic Loads.	CTA 50-900 TB MED	Clothing and Equipment. Storage, Preservation, Packaging, Packing Maintenance and Surveillance of Materiel: Medical Activities.
<i>g. Plans.</i>			
	DA Civil Disturbance Plan (Garden Plot).		
	DA Postal Augmentation Plan (Graphic Hand).	TB 740-10	Quality Control Depot Serviceability Standards (DALM 4155-5) (S&I Cdr, Letterkenny Army Depot, Chambersburg, PA 17301).
<i>h. Miscellaneous Publications.</i>			
AMC-R 500-1	Emergency Employment of Army and Other Resources—Emergency Planning.		

APPENDIX J

DEFINITIONS

Section 1. DEFINITION OF COMMONLY USED TERMS

The DOD Dictionary (JCS Pub. 1) provides definitions of a wide variety of commonly used military terms. There are some terms, not listed in the DOD Dictionary, that are used in Joint Operations Planning System (JOPS), the Joint Reporting Structure, other Joint Chiefs of Staff (JCS) publications, and in the joint planning community. The following is a list of selected terms used in this publication along with a practical definition for each.

Acquisition

The purchasing, renting, leasing, or otherwise obtaining of personnel, services, supplies, and equipment from authorized sources as prescribed by the Defense Acquisition Regulation.

Acquisition Leadtime

The time elapsed between placing an order to purchase an item and receiving the item into the supply system.

Alert Order

A formal directive issued by the JCS. It reflects a National Command Authorities' (NCA) decision that US military forces may be required, provides essential guidance for planning in the prevailing situation, and marks the outset of execution planning.

Alternate Files

Essential directives, instructions, programs, plans, emergency actions procedures, and other documents required for the conduct of essential functions in a national emergency situation. The alternate files are maintained when practicable at the alternate or relocation sites.

Alternate Site

A prepared, predesignated location to which all or portions of a civilian or military headquarters may be evacuated. It should be capable of rapid activation and expansion. This applies principally to national level organizations.

Attachments to an Operation Plan or Order

An attachment to an operation plan or order is a separately identifiable amplification of the basic plan or operation order. Attachments are annexes, appendixes, tabs, and enclosures.

Augmentation Forces

Forces to be transferred to the operational command of a supported commander during the execution of an operation plan approved by the Joint Chiefs of Staff (JOPS)

Authorized Stockage List (ASL)

All items authorized to be stocked at a specific echelon of supply. The following are, or constitute parts of, the ASL of Tables of Organization and Equipment (TOE) and Tables of Distribution and Allowances (TDA) units:

a. Mission load. Quantity of class IX supplies authorized to be on hand in support units, or stored in depots for them, which will permit the unit to accomplish its peacetime and combat role support mission until resupply can be effected. The mission load is related to direct support (DS)/general support (GS) maintenance, as well as the resupply of prescribed and mission loads of supported units. Mission loads in the hands of units should normally be transportable on unit vehicles. The mission load is generally computed in 15-day increments and is basically designed to satisfy combat requirements.

b. Prescribed load.

(1) That quantity of class I and II supplies authorized by the major commander within criteria established by the Department of the Army (DA) to be on hand in units. The prescribed load is carried by the individual or on unit transportation and is continuously replenished as consumed.

(2) Quantity of class II, IV, IX supplies authorized by major commanders in accordance with AR 710-2 to be on hand in units for the performance

of organizational maintenance on assigned equipment. The prescribed load is carried on unit transportation and enables the unit to sustain itself during combat operations until resupply can be effected (normally 15-day level). The prescribed load is continuously replenished as consumed.

Basic Plan

That part of an operation plan which forms the base structure for annexes and appendixes. It consists of general statements related to the situation, mission, execution, logistics, administration, and command and signal.

Contiguous Zone

The entire zone, contiguous to the territorial sea, established by the United States under Article 24 of the Convention of the Territorial Sea and the Contiguous Zone.

Contingency Support Stocks (CONSSTOCS)

That portion of general war reserves which is maintained in the Continental United States (CONUS) for initial supply of CONUS forces deployed/employed for contingency operations. CONSSTOCS include Army-managed items and that portion of the Defense Logistics Agency (DLA) and General Services Administration (GSA)-managed Army-owned items which meet the established criteria.

Continuity of Government

All measures designed or taken to insure the continuity of essential functions of Government in event of an enemy attack.

CONUS Terminal Arrival Date (CTAD)

The date (related to C/D-Day) expressed in the OPLAN for materiel to arrive at the CONUS air/water terminal to provide ontime delivery to the consignee.

Crisis Action System (CAS)

CAS provides guidance and procedures for the conduct of joint planning for the use of military forces during emergency or time-sensitive situations for which there is no existing OPLAN.

Deployability Posture

The state or stage of a unit's preparedness for deployment to participate in a military operation.

Deployment Planning

That part of operation planning which concerns the relocation of forces to the desired area of operation.

Deployment-Qualified Equipment

Equipment free of conditions that would limit the reliability performance of its primary mission under combat conditions for a period of 90 days of operations and scored READY in accordance with applicable Equipment Serviceability Criteria (ESC).

Discharge

Includes, but is not limited to, any spilling, leaking, pumping, pouring, emitting, emptying, or dumping. Discharges, as used in this directive, do not include those which are within the limits and criteria of appropriate Federal or State permits.

Elements of an Operation Plan or Order

An element of an operation plan or order is an item which is listed in the table of contents including the attachments to the operation plan or order.

Emergency Staff Designee

Individuals or staff groups, who with minimal prior warning, can move to designated alternate/relocation sites, form an emergency staff, and conduct essential functions.

Employment Planning

That part of operation planning which concerns the strategic or tactical use of forces and materiel within the area of operations.

End Item Density

The quantity of end items requiring maintenance and supply support in a command or geographical area.

End Strength

Actual or authorized strength of the Army or subdivision thereof, at the close of a specific time period (fiscal year, calendar year, month, or operation).

Equipment Requirements Data/ Equipment Density Data (ERD/ EDD)

A listing of all equipment authorized by TOE/ Table of Allowance (TA), Modification Table of Organization and Equipment (MTOE)/Modification Table of Allowance (MTA) and Modification Table of Distribution and Allowances (MTDA)/TDA, equipment assets reported by units (AR 710-3), and equipment assets contained in approved Operational Projects (AR 710-1), by a six-digit alphanumeric line item number (SB 700-20), National Stock Number (NSN), nomenclature, make and model and quantity for each unit/organization or

part thereof. ERD/EDD are used as the basis for computing supply in support of contingency operations.

Essential Functions

Those functions of the Department of Defense (DOD) activities which are deemed necessary for the activity head in consonance with the directions of the Secretary of Defense for the accomplishment of indispensable operations of DOD in national emergency situations.

Execution Planning

That part of operation planning in which a plan or concept is translated into an operation order. It includes adapting the plan or concept to the prevailing circumstances, the designation of units to satisfy force requirements, the establishment of appropriate deployability posture, the scheduling of necessary transportation resources and the dissemination of movement tables to regulate the deployment of forces requiring common-user transportation.

Force Requirements Number (FRN)

The alphanumeric code used to uniquely identify each force entry in a force list, Time-Phased Force Deployment List (TPFDL), etc. (JOPS).

Force Shortfall

A deficiency in the number or type of units available for planning, within the time required for the performance of an assigned task.

Fragmented Unit

Any unit that does not enter a specific objective area as a complete unit. A unit is considered to be fragmented if portions of the unit are deployed to the objective area at different times, by different modes of transport, to different objective areas, or if a portion of the unit is not deployed. Lettered companies and unnumbered TOE detachments and teams organic to battalions or companies are not fragmented units unless one or more of the above conditions exist. For purpose of computing density data, all reportable items in SB 700-20 and all equipment items requiring repair parts support are used.

General-Purpose Warehouse Space

Warehouse area other than controlled humidity, flammable, or refrigerated warehouse area. Such warehouse area may be further classified either as heated or unheated warehouse space.

Gross Storage Space

a. The overall space at an installation or activity designated as the storage asset. This does not in-

clude areas that have been converted to nonstorage purposes; e.g., shops and offices.

b. The inside area between exterior walls without deduction for firewalls and other structural losses. The overall measurements of open storage areas without deduction for trackage and permanent roads within the area.

Harmful Quantities

That quantity of oil which is harmful to public health or welfare; or violates applicable water quality standards; or causes a film, sheen, or discoloration of the water surface or adjacent shorelines; or causes a sludge or emulsion to be deposited beneath the water surface or upon adjacent shorelines. A direct discharge of oil from a properly functioning vessel engine is not deemed to be harmful; but such oil accumulated in a vessel's bilge and subsequently discharged shall not be so exempt.

Hazardous Substances

A material, other than oil, which, when discharged in any quantity into or upon waters of the United States, adjoining shorelines, or waters of the contiguous zone, presents an imminent and substantial danger to the public health or welfare, including, but not limited to, fish, shellfish, wildlife, shorelines, and beaches. This definition will apply to the DOD program until such time as a definitive list of hazardous substances is issued pursuant to Section 311(b)(2) of the Federal Water Pollution-Control Act, as amended (reference (g)).

Highway Capability

The number of vehicles (highway vehicle capability) or the number of short tons payload (highway tonnage capability) which can be moved over a highway with proper consideration of type of roadway, maintenance, hills, curves, weather, other traffic, type of vehicle employed, etc.

Highway Capacity

Maximum traffic obtainable on a given roadway using all available lanes.

Initial Strength

Actual or authorized strength of the Army, or subdivision thereof, at the beginning of a specific time period (fiscal year, calendar year, month of operation).

The Joint Operation Planning System (JOPS)

The planning system approved by the JCS and directed for use in joint planning. JOPS formalizes

and standardizes administrative procedure, data exchange and storage, and plan format.

Joint Strategic Planning System (JSPS)

Strategic planning is the first phase of the Planning, Programming, and Budgeting System (PPBS). It is accomplished by the JCS and translates the national security policy into strategic guidance, direction, and objectives for force structuring, resource programming, and operational planning. Included in the planning documents which make up part of the JSPS, are the:

- a. Joint Strategic Objectives Plan (JSOP).
- b. Joint Strategic Capabilities Plan (JSCP).
- c. Joint Force Memorandum (JFM).
- d. Joint Research and Development Objectives Document (JRDO).

Limiting Factor

A deficiency in resources required to support an operation plan, such as movement capabilities, personnel, logistics, or facilities.

Logistics Over-the-Shore Operations (LOTS)

The loading and unloading of ships without the benefit of fixed-port facilities in friendly or nondefended territory; and, in time of war, during phases of theater development in which there is no opposition by the enemy.

Major Army Command (MACOM)

A specifically designated Army field command directly subordinate to Headquarters, Department of the Army (HQDA).

Materiel Management Center (MMC)

Functional control centers normally assigned to Division Support Command (DISCOM), Corps Support Command (COSCOM), Theater Area Army Command (TAACOM), and Theater Army Headquarters (TA HQ). MMCs are responsible for those phases of military logistics which include managing, cataloging, requirements determination, acquisition, distribution, overhaul, disposal, and actions taken to retain equipment in a serviceable condition. It incorporates the functions of inventory control, supply control, stock control, and maintenance management.

Mobility Echelon

A subordinate element of a type unit which is scheduled for deployment separately from the parent unit. Mobility echelons may be used in the Time-Phased Transportation Requirement List (TPTRL), but normally do not appear in a TPFDL.

Movements Control Center (MCC)

Functional control centers normally assigned to COSCOM and TA HQ. MCCs are responsible for planning, routing, scheduling, and control of personnel and supply movements over lines of communication.

National Inventory Control Point (NICP)

An agency of the US Army Materiel Command (AMC) or the DLA that is responsible for the worldwide inventory management of certain commodities assigned to that point. The management responsibilities include cataloging, requirements computations, acquisition direction, distribution management, overhaul direction, and disposal direction.

National Maintenance Point (NMP)

An organization that provides maintenance guidance to equipment users worldwide; the major functions of an NMP are maintenance engineering, preparing technical publications, providing logistics assistance, and performing maintenance management.

The National Military Command System (NMCS)

The NMCS is the priority component of the Worldwide Military Command and Control System (WWMCCS) designed to support the NCAs in the exercise of their responsibilities. It also supports the JCS in the exercise of their responsibilities.

Net Storage Space

The floor area upon which bins are erected plus the floor area upon which materiel can be stored.

Nonunit-Related Cargo

All equipment and supplies requiring transportation to an area of operations, other than those identified as the equipment or accompanying supplies of a specific unit, (e.g., resupply, military support for allies, support for nonmilitary programs, such as civil relief, etc.).

Nonunit-Related Personnel

All personnel requiring transportation to an area of operations, other than those assigned to a specific unit (e.g., fillers, replacements, TDY/TAD, civilians, etc.).

Notional Unit

A type unit without specific identity as to numerical or other actual designation, such as an infantry division, an artillery battalion, or a supply and service battalion.

Offshore Acquisitions

The purchase of materiel requirements in countries outside the United States and its possessions and Canada with delivery to recipient countries or for US forces wherever stationed.

Operation Plan (OPLAN) Categories

a. Contingency Plan. A plan for an emergency which may occur in a specific geographic subarea of a command. The primary purpose of a contingency plan is to accelerate the actions which this command can take to react to the emergency situation.

b. Supporting Plan. A plan for deployment of the forces of one unified command to augment another.

c. Deployment Plan. A plan developed by an Army component command (FORSCOM/ARRED) that provides for the deployment of assigned Army forces in support of a unified command (CINCRED) supporting plan and in support of a unified command (LANTCOM) and Army component command (ARLANT) operation plans.

d. Employment Plan. A plan developed by Army component commands (FORSCOM/ARLANT) or a designated/employment planning agent (XVII Airborne Corps) that provides for the employment of the Army component commands (ARLANT) forces in support of the unified command (LANTCOM). Additionally, joint employment plans are developed, as directed by a unified commander (CINCLANT), that provide for the employment of joint forces (ARLANT, AFLANT, LANTFLT) in the area of operations.

e. Consolidated Plans. A plan developed jointly by a component command (FORSCOM/ARLANT) and the designated planning agent (XVIII Airborne Corps) that incorporates the deployment and employment planning necessary to support a unified command's (LANTCOM) contingency plan.

f. Base Development Plan (BDP). A plan developed by an Army component command (FORSCOM/ARLANT) in support of employment and consolidated plans (d and e above), which identifies logistics and operational facility requirements and provides for the acquisition or construction and for maintenance of those facilities.

g. General Plans. Plans developed by Army component commands (FORSCOM/ARRED) in support of unified commands (REDCOM) general plans, directives, or other documents. These plans establish broad guidance and data bases necessary for development of other type plans within the planning system.

Operation Plan in Complete Format

An OPLAN for the conduct of military operations which can be translated into an operation order with minimum alteration. The designation "plan" is often used instead of "order" in preparing for operations well in advance. Complete plans include deployment and/or employment phases, as appropriate. All areas of the plan are fully developed to include the complete force tab/troop list and other essential annexes.

Operation Plan in Concept Format

An operation plan in an abbreviated format, requiring further expansion prior to execution. The plan outlines the salient features or principles of a course of action which is used to complete detailed planning.

Operational Project

A DA-approved project authorizing the acquisition of stocks of equipment and supplies for the support of a specific requirement, developed in accordance with AR 710-1.

Overseas Terminal Arrival Date (OTAD)

The date (related to C/D-day expressed in the OPLAN for materiel to arrive at the overseas air/water terminal for discharge and transshipment to the consignee.

Planning Agent

A subordinate headquarters of an Army component command designated to accomplish specific planning and/or execution tasks in support of contingency plans and requirements. A planning agent may be designated to accomplish staging/marshaling planning, deployment, employment, e.g.:

a. FORSCOM/ARLANT subordinate command, XVIII Airborne Corps, may be designated as the employment planning agent in support of LANTCOM or of an overseas unified command, or be designated to develop Army Task Force plans in support of a Joint Task Force (JTF) established by a unified command.

b. An employment planning agent prepares a ground tactical plan or other supporting plans to include appropriate annexes to support the concept of operation of the unified command, Army component command, other commands, a JTF, as appropriate.

Plan Summary

A required element of an operation plan which provides a brief recapitulation of the mission, the general situation, the concept of operations, the

major forces required, command arrangements, and the commander's appraisal of logistics feasibility.

Planning Point of Origin

A geographic location in which forces, supplies, and equipment are assembled.

Posthostilities Planning

The planning for orderly dismantling of facilities and redeploying of men and materiel no longer required in support of operations.

Preplanned Supply

A system by which supply requirements are computed by wholesale logistics activities, with participation of the supported command, for the initial support of forces through the development period on the basis of forecasted or established replacement factors/consumption rates and prior to establishment of normal requisitioning capabilities. Supplies are incrementally shipped to the responsible supporting theater/task force logistics activity(s), on an as-required basis, to supplement and/or establish a theater/task force stock level to enable that activity(s) to respond to requisitions submitted by supported units.

Project Codes

A three-position alpha or numeric code used to identify requisitions, supply and transportation documentation, and shipment of materiel to consignee (unit).

Project Stocks

Those items of supply and equipment included in operational projects to support specific operations, contingencies and/or war plans.

Reception Capacity

The number and types of ships that can be moved into a harbor or coastal area of the terminal per day. This capacity is an estimated tonnage that can be accommodated for discharge daily from the ships and is based solely on an evaluation of the physical facilities of the terminal.

Reconstitution

Actions taken under the surviving command authority to reform a damaged or destroyed headquarters from survivors of the attack and/or personnel from other sources, predesignated as replacements.

Reserve Supplies

a Supplies over and above immediate operational requirements.

b Supplies authorized to be retained for a specific purpose, such as war reserves, contingency

plans, equipping newly activated units or units arriving in the theater without equipment.

c War reserves are stocks of materiel acquired in peacetime to meet increased military requirements consequent to an outbreak of war. These reserves are intended to provide support to sustain operations until resupply can be accomplished. DA, DCSLOG must approve establishment of Army war reserve stocks outside of CONUS. War reserve stocks, as described in AR 11-11 and AR 710-1 are composed of:

(1) Pre-Positioned War Reserve Materiel Stocks (PWRMS).

(2) CONSSTOCS.

(3) Priority Mobilization War Reserves (PRIMOB) for early mission reserve components.

(4) Full Army Mobilization War Reserves (FAM).

(5) War Reserve Stocks for Allies (WRSA).

(6) Special Contingency Stockpile (SCS).

(7) operational Project Stocks (OPS).

(8) Other War Reserve Materiel Stocks (OWRMS).

d War Reserve Stockage List (WARSL) is a listing of principal and secondary end items authorized by command for stockage in war reserves for use by US forces. The list is published in SB 700-40. Not listed but also authorized for stockage are components and repair parts for mobilization support of WARSL end items.

Retrograde Cargo

Cargo being returned from an oversea command to CONUS.

Roll-On/Roll-Off (RORO)

Ocean shipping in which vehicles (wheeled or tracked) are driven aboard a special vessel, secured for the voyage and driven off at destination port.

Routine Replenishment

Supply of a deployed force after termination of preplanned supply, based on requisitions submitted by the task force or theater commander (FORSCOM Reg 700-2).

Scheduled Supply

A system whereby any unit (user or supplier) is furnished some or all of its supply requirements by a previously planned schedule which specifies items, quantities, and time and place of delivery.

Serviceable Equipment

Equipment that fully meets the prescribed maintenance standards set forth in TM or other DA technical publications and is capable of performing its prescribed function at rated capacity for a period of 90 days under combat conditions (FORSCOM Reg 700-2).

Services

The Chief of Staff, US Army; the Chief of Naval Operations; the Chief of Staff US Air Force; the Commandant of the Marine Corps, and their respective headquarters staffs (DARCOM LP&P).

Special Facility (SF)

The Office of Preparedness, GSA, SF is a protected emergency site for those elements of DOD responsible for the centralized management and control of resources and the claiming for and allocation of national resources for DOD purposes. In addition, the SF is designed to provide selected civil agencies and departments of the Federal Government with a facility and a mechanism which will permit response to Presidential direction, the making of policy decisions, the announcement of those decisions, and the exercise and control over their implementation.

Specified Command

A command which has a broad continuing mission and which is established and so designated by the President through the Secretary of Defense with the advice and assistance of the JCS. Normally, it is composed of forces from but one service.

Stockage Lists

A list of all items authorized to be stocked at a specified supply echelon.

a. Authorized Stockage List. A listing of repair parts, general supplies, common hardware, and special tools required by maintenance and supply units to perform maintenance and/or to resupply supported units.

b. Prescribed Load List. A composite listing of repair parts and special tools authorized to a unit to perform organizational maintenance.

Succession of Command

Whereby a subordinate commander substitutes for and assumes the authority, duties, and functions of a senior disabled commander.

Supplies

Supplies are the commodities necessary to equip, maintain, and operate a military command. Military services divide supplies into general classes for planning and administrative purposes. (See AR

11-8 and FM 704-28.) These classes of supplies are as follows:

a. Class I. Subsistence.

b. Class II. Clothing, individual equipment, tentage, organizational tool sets and tool kits, handtools, administrative and housekeeping supplies, and equipment.

c. Class III. POL, petroleum fuels, lubricants, hydraulic and insulating oils, preservatives, liquid and compressed gases, bulk chemical products, coolants, deicing and antifreeze compounds, together with components and additives of such products, and coal.

d. Class IV. Construction. Construction materials to include installed equipment and all fortification/barrier materials.

e. Class V. Ammunition. Ammunition of all types (including chemical, biological, radiological, and special weapons), bombs, explosives, mines, fuses, detonators, pyrotechnics, missiles, rockets, propellants, and other associated items.

f. Class VI. Personal demand items (nonmilitary sales items).

g. Class VII. Major end items. A final combination of end products which is ready for its intended use; e.g., launchers, tanks, mobile machine shops, vehicles.

h. Class VIII. Medical materiel, including medical-peculiar repair parts.

i. Class IX. Repair parts (less medical-peculiar repair parts). All repair parts and components to include kits, assemblies, and subassemblies, repairable and nonrepairable, required for maintenance support of all equipment.

j. Class X. Materiel to support nonmilitary programs; e.g., agricultural and economic development, not included in classes I through IX.

Supported CINC

A commander of a unified or specified command who is assigned a mission in the JSCP or by directive of the JCS for the conduct of operations and who prepares operation plans for the conduct of such operations.

Supporting CINC

A commander of a unified or specified command who provides forces to a supported commander of a unified or specified command.

Supporting Forces

Forces stationed in, or to be deployed to, an area of operations to provide support for the execution of an operation plan approved by the JCS. Oper-

ational command of supporting forces is not passed to the supported commander.

Supporting Plan

An operation plan prepared by either a supporting commander or a subordinate commander to satisfy the requests/requirements of the supported commander's plan (JOPS).

Sustaining Supply

That materiel required to support a unit after arrival in theater from the time accompanying supply and PWRMS are anticipated to run out, until regular resupply commences (JOPS III).

Terminal Throughput Capacity

An estimate of the existing terminal capacity which is the total tonnage and/or personnel that can be received, processed, and cleared through the terminal in a day.

Theater Medical Evacuation Policy

The maximum period, established by the Secretary of Defense, that patients may be held within the theater for treatment. The theater Army commander normally establishes intratheater evacuation (holding) policies for the combat zone and the communications zone (COMMZ).

Time-Phased Force Deployment Data (TPFDD)

The time-phased force and transportation data for an OPLAN, including:

- a. Type units to be employed.
- b. Type units to be deployed to support the OPLAN with a priority indicating the desired sequence for their arrival at port of debarkation (POD).
- c. Routing of forces to be deployed.
- d. Mobility data associated with deploying forces.
- e. *Personnel and logistics movements to be conducted concurrently with the deployment of forces.*
- f. Estimate of transportation requirements, which must be fulfilled by common-user lift resources as well as those requirements which can be fulfilled by assigned or attached transportation resources (JOPS).

Time-Phased Force and Deployment List (TPFDL)

A part of the TPFDD which includes a time-phased force list, identifies type units to be deployed, and provides data concerning their destination (JOPS).

Time-Phased Transportation Requirements List

A part of the TPFDD which defines the movement requirements and includes a time-phased listing of type units/mobility echelons, fillers and replacement personnel, and bulk supplies to be transported by air or sea to support an OPLAN; provides mobility data related to these deployments; and estimates movement requirements to be fulfilled by both common-user lift resources and assigned transportation resources (JOPS).

Transportation Movement Requirements Data (TMRD)

A listing or card deck of supplies in shipping configuration that will be shipped in support of a contingency operation. The supplies will be identified by class of supply, weight, dimensions, special handling characteristics mode(s) of transportation, markings (project code) to be used, supply source, and recommended aerial port of embarkation (APOE) or POE (AMC LP&P).

Type Unit

A type of organizational entity established within the Armed Forces and uniquely identified by a unit type code (JOPS).

Type Unit Data (TUCHA) File

The TUCHA file provides standard planning data on movement characteristics for personnel, cargo, and accompanying supplies associated with deployable type units of fixed composition. The file contains the weight and cube of selected cargo categories, physical characteristics of the cargo, and the number of personnel requiring nonorganic transportation (JOPS).

Unit Designation List

A list of actual units designated to fulfill requirements of a force list (JOPS).

Unit Identification Code (UIC)

A six-character, alphanumeric code which uniquely identifies each Active, Reserve, and National Guard unit of the Armed Forces (JOPS).

Unit Type Code (UTC)

The five-character, alphanumeric code which is associated with and allows each type unit/organization to be categorized into a kind or class having common distinguishing characteristics (JOPS).

Unit-Related Equipment and Supplies

All equipment and supplies requiring transportation to an area of operations that are assigned to a

specific unit or that are designated as accompanying supplies.

War Reserves

Stocks of materiel amassed in peacetime to meet the increase in military requirements consequent upon an outbreak of war. They are intended to provide the interim support essential to sustain operations until resupply can be effected.

Waters of the United States

The navigable waters of the United States; tributaries of navigable waters of the United States; interstate and intrastate lakes, rivers, and streams.

Worldwide Military Command and Control System

A formalized structure for the exercise of authority and direction by duly designated authorities in performing the functions of planning, directing, coordinating, and controlling military forces. It consists of five major components: (1) the National Military Command System (NMCS); (2) the WWMCCS-related management information systems of the headquarters of the military departments; (3) the command and control systems of the unified and specified commands; (4) the command and control systems of the headquarters of the service component commands; and (5) the command and control support system of the DOD agencies.

Section II. ACRONYMS AND ABBREVIATIONS

The following is a list of selected acronyms that are frequently used in planning. Generally, acronyms and abbreviations should be avoided in the writing of joint plans and orders. If a long title or term must be used repeatedly, the acronym or abbreviation may be employed provided the first time it is used the long title is spelled out fully along with its related acronym or abbreviation.

- AAO..... Army Acquisition Objective
- ADP..... Automatic Data Processing
- AFCS..... Army Facilities Components System
- AIPP..... Army Industrial Preparedness Program
- AM..... US Army Materiel Command
- AMCCOM..... US Army Armament, Munitions and Chemical Command
- AMOPS..... Army Mobilization and Operations Planning System
- AMP..... Army Materiel Plan
- APORTS..... Aerial Ports and Air Operating Bases File
- ARCOM..... US Army Reserve Command
- ARNG..... US Army National Guard
- ASA..... Army Strategic Appraisal
- ASF..... Army Stock Fund
- ASL..... Authorized Stockage List
- ASSETS..... Transportation Assets File
- AUTODIN..... Automatic Digital Network
- BD..... Base Development
- BDP..... Base Development Plan
- CAS..... Crisis Action System
- CB..... Chemical Biological
- CUE..... Communications Electronics
- CECOM..... US Army Communications and Electronics Command
- CEF..... Civil Engineering File

- CUSP..... Civil Engineering Support Plan
- CESPG..... Civil Engineering Support Plan Generator
- CHSTR..... Characteristics of Transportation Resource File
- CIA..... Central Intelligence Agency
- CINC..... Commander in Chief
- COMMA..... Communications Zone
- COMPASS..... Computerized Movements Planning and Status System
- COMSEC..... Communications Security Equipment
- CONPLAN..... Concept Plan
- CONUS..... Continental United States
- COOP..... Continuity of Operations Planning
- COSCOM..... Corps Support Command
- CSS..... Combat Service Support
- CTA..... Common Table of Allowance
- CTAD..... CONUS Terminal Arrival Date
- CZ..... Combat Zone
- DA..... Department of Army
- DCAS..... Defense Contract Administration Service
- DCSLOG..... Deputy Chief of Staff for Logistics
- DCSOPS..... Deputy Chief of Staff for Operations and Plans
- DCSPER..... Deputy Chief of Staff for Personnel
- DCSRDA..... Deputy Chief of Staff for Research, Development and Acquisition
- DESCOM..... Depot System Command
- DFSC..... Defense Fuel Supply Center
- DG..... Defense Guidance
- DISCOM..... Division Support Command
- DLA..... Defense Logistics Agency
- DOD..... Department of Defense
- DODD..... Department of Defense Instruction
- DOE..... Department of Energy

FM 701-58

DOT.....	Department of Transportation	JTF.....	Joint Task Force
DPSC.....	Defense Personnel Support Center	LAD.....	Latest Arrival Date
DS.....	Direct Support	LCA.....	Logistics Control Activity
DSS.....	Direct Support System	LEA.....	Logistic Evaluation Agency
EAC.....	Echelons Above Corps	LFF.....	Logistics Factors File
ENCOM.....	Engineer Command	LSA.....	Logistics Support Analysis
EPW.....	Enemy Prisoner of War	MAC.....	Military Airlift Command
FASTALS.....	Force Analysis Simulation of Theater Administration and Logistics support	MACOM.....	Major Army Command
FMS.....	Foreign Military Sales	MAP.....	Military Assistance Program
FORSCOM.....	US Army Forces Command	MAPS.....	Mobility Analysis & Planning System
FRAGORD.....	Fragmentary Order	MCC.....	Movement Control Center
FRG.....	Force Requirements Generator	MEDCOM.....	Medical Command
FRN.....	Force Requirement Number	MEDSOM.....	Medical, Supply, Optical, and Maintenance
FSS.....	Federal Supply Schedule	MEMO.....	Mission Essential Maintenance Operations/Capabilities
FTS.....	Federal Telecommunications System	MFL.....	Master Force List (JDS) Major Force List (JOPS)
FYDP.....	Five-Year Defense Program	MILPERCEN.....	Military Personnel Center
GEOFILE.....	Specified Geolocation Code File	MILSTAMP.....	Military Standard Transportation and Movement Procedures
GS.....	General Support	MILSTEP.....	Military Supply and Transportation Evaluation Procedures
GSA.....	General Supply Administration	MILSTRIP.....	Military Standard Requisitioning and Issue Procedures
HNS.....	Host Nation Support	MMC.....	Materiel Management Center
IDSM.....	Intermediate Direct Support Maintenance	MPM.....	Medical Planning Module
IGSM.....	Intermediate General Support Maintenance	MRG.....	Movement Requirements Generator
IMAPS.....	Integrated Military Airlift Planning System (MAC)	MRM.....	Maintenance Reporting and Management System
INSCOM.....	US Army Intelligence and Security Command	MRSA.....	Materiel Readiness Support Activity
IPPL.....	Industrial Preparedness Planning	MSC.....	Military Sealift Command or Major Subordinate Command
IPSP.....	Intelligence Priorities for Strategic Planning	MSL.....	Master Support
IPSS.....	Initial Pre-planned Supply Support	MTDA.....	Modification Table of Distribution and Allowances
JCS.....	Joint Chiefs of Staff	MTMC.....	Military Traffic Management Command
JDA.....	Joint Deployment Agency	MTOE.....	Modified Table of Organization and Equipment
JDS.....	Joint Deployment System	MUMDF.....	Medical Unique Master Data File
JIEP.....	Joint Intelligence Estimate for Planning	NATO.....	North Atlantic Treaty Organization
JLRSA.....	Joint Long-Range Strategic Analysis (JSPS)	NCA.....	National Command Authorities
JOPS.....	Joint Operation Planning System	NICP.....	National Inventory Control Point
JOPSREP.....	JOPS Reporting System	NMCC.....	National Military Command Center
JPAM.....	Joint Program Assessment Memorandum (JSPS)	NMP.....	National Maintenance Point
JPO.....	Joint Petroleum Office	NRC.....	Nuclear Regulatory Commission
JRS.....	Joint Reporting Structure	NSC.....	National Security Council
JSAM.....	Joint Security Assistance Memorandum	OJCS.....	Organization of the Joint Chiefs of Staff
JSCP.....	Joint Strategic Capabilities Plan (JSPS)		
JSPD.....	Joint Strategic Planning Document (JSPS)		
JSPS.....	Joint Strategic Planning System		
JTB.....	Joint Transportation Board		

OPLAN.....	Operations Plan in complete format.	TECOM.....	US Army Test and Evaluation Command
OPREP.....	Commander's Operational Report (JRS)	TFE.....	Transportation Feasibility Estimator
ORF.....	Operational Readiness Float	TMDE.....	Test Measurement and Diagnostic Equipment
OSD.....	Office of the Secretary of Defense	TMRD.....	Transportation Movement Requirement Document
OST.....	Order Ship Time	TOA.....	Transportation Operating Agency
OTAD.....	Overseas Terminal Arrival Date	TOE.....	Table of Organization and Equipment
PA.....	Procurement Army	TPFDD.....	Time and Phased Force Deployment Data
PDP.....	Plan Development Phase (JOPS)	TPFDL.....	Time-Phased Force Deployment List
PERSCOM.....	Personnel Command	TPTRL.....	Time-Phased Transportation Requirement List
PM.....	Preventive Medicine	TRADOC.....	US Army Training and Doctrine Command
POD.....	Port of Debarkation/Discharge	TRANSCOM...	Transportation Command
POE.....	Port of Embarkation	TSA.....	US Army Troop Support Agency
POL.....	Petroleum, Oils, and Lubricants	TSG.....	The Surgeon General
POMCUS.....	Prepositioned Organizational Materiel Configured to Unit Sets	TUCHA.....	Type Unit Data File
PORTS.....	Port Characteristics File	TUDET.....	Type Unit Equipment Detail File
POS.....	Port of support	UCP.....	Unified Command Plan
PPBS.....	Planning, Programing, and Budgeting System	ULC.....	Unit Level Code
PVNTMED.....	Preventive Medicine	UMD.....	Unit Movements Data
PWRS.....	Pre-Positioned War Reserve Stock	USAAF.....	Unified Action Armed Forces
RDD.....	Required Delivery Date	USAISC.....	US Army Information Systems Command
SACS.....	Structure and Composition System	USAMMA.....	US Army Medical Materiel Agency
SAR.....	Search and Rescue	USAR.....	US Army Reserve
SEACOP.....	Strategic Sealift Contingency Planning System (MSC)	USASAC.....	US Army Security Assistance Center
SICC.....	Service Item Control Center	USDA.....	US Department of Agriculture
SITREP.....	Situation Report	USPS.....	US Postal Service
SL.....	Safety Level	UTC.....	Unit Type Code
SM.....	Systems Monitor	UW.....	Unconventional Warfare
SOP.....	Standing Operating Procedure	VIP.....	Visual Information Project Terminal
SPIRE.....	Spot Intelligence Report	WARSL.....	War Reserve Mobilization Stockage List
SRC.....	Standard Requirement Code	WIN.....	WWMCCS Intercomputer Network
SRF.....	Summary Reference File	WRMR.....	War Reserve Materiel Requirement
TAACOM.....	Theater Army Area Command	WRMS	War Reserve Materiel Stock
TAADS.....	The Army Authorization Document System	WWMCCS . . .	Worldwide Military Command and Control System
TAEDP.....	Total Army Equipment Distribution Program		
TAMMC.....	Theater Army Materiel Management Center		
TAP.....	The Army Plan		
TCC.....	Theater Communications Command		
TDA.....	Table of Distribution and Allowance		

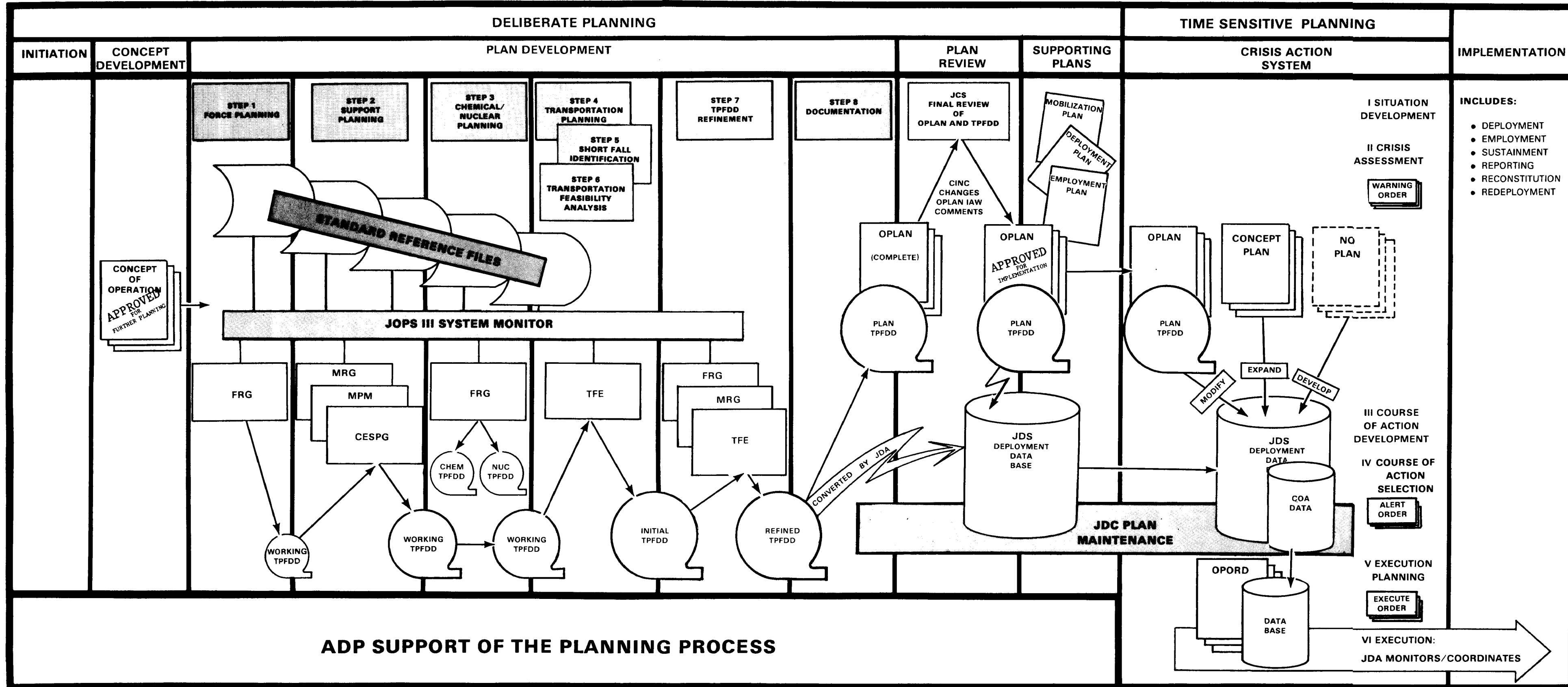

Figure 5-2. ADP support of the planning process.

PLAN DEVELOPMENT PHASE

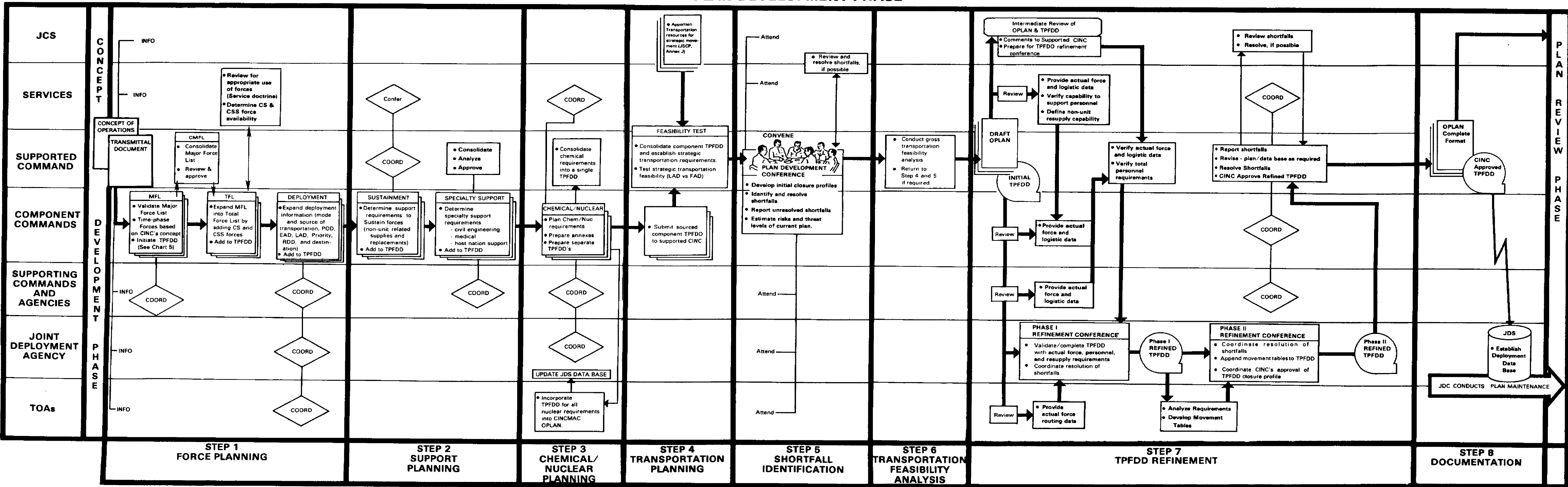

Figure 5-5. The plan development phase.

By Order of the Secretary of the Army:

JOHN A. WICKHAM, JR.
General, United States Army
Chief of Staff

Official:

R. L. DILWORTH
Brigadier General, United States
Army
The Adjutant General

DISTRIBUTION:

ACTIVE ARMY USAR, ARNG: To be distributed in accordance with DA Form 12-11A requirements for Planning Logistics Support for Military Operations.

U.S. GOVERNMENT PRINTING OFFICE : 1987 O—177-476